

ZW-6 series

HITACHI

Reliable solutions

# ZW65/75/95



## COMPACT WHEEL LOADER

Model code : ZW65 / ZW75 / ZW95

Engine rated power : ZW65 : 50 kW / ZW75 : 50 kW / ZW95 : 55.4 kW

Operating weight : ZW65 : 4 710 kg / ZW75 : 5 050 kg / ZW95 : 5 410 kg

Bucket ISO heaped : ZW65 : 0.70 – 1.20 m<sup>3</sup> / ZW75 : 0.80 – 1.50 m<sup>3</sup> / ZW95 : 1.00 – 1.60 m<sup>3</sup>

# ZW65-6, ZW75-6 AND ZW95-6. NO COMPROMISE

The new Hitachi compact wheel loaders have been developed specifically to meet the demands of the evolving European construction industry. The ZW65-6, ZW75-6 and ZW95-6 offer exceptional levels of performance without compromising on efficiency, thanks to low levels of fuel consumption.

The new line-up reinforces Hitachi's reputation for durable products. Ideal for a wide range of applications, the ZW65-6, ZW75-6 and ZW95-6 are extremely versatile, offer a comfortable working environment and set a new standard for reliability.



6. RENOWNED FOR RELIABILITY



8. DESIGNED FOR DURABILITY



10. OUTSTANDING VERSATILITY



12. THE HIGHEST QUALITY



14. SUPERIOR TECHNOLOGY

# DEMAND PERFECTION

The new range of Hitachi compact wheel loaders has been designed and built using market-leading technology with an emphasis on the environment and operator safety. Developed to perfection, the design of the ZW65-6, ZW75-6 and ZW95-6 has been continuously updated to deliver exceptional productivity at the lowest possible cost of ownership.



**All-round visibility**  
A 360° panoramic view from the cab.



**High quality**  
Only the best design elements and materials.



**Exceptional reliability**  
500-hour service intervals.



**Excellent versatility**  
Four-metre maximum transportation height (on trailer).



**Incredibly durable**  
Powerful, low-torsion monoboam.





**Highly productive**

Higher dumping speed and optimal pull-out force.



**Environmentally friendly**

Hydraulically driven engine fan helps to reduce emissions.



**First-rate efficiency and safety**

Electro-hydraulic quick coupler.



**Convenient access**

Easy-to-open engine cover.



**Less maintenance**

New Deutz Stage IIIB-compliant engine.



**Ultimate comfort**

Ergonomic controls and easy access to the cab.



**Greater stability**

Self-stabilising articulated pendulum joint.





“ No other equipment works as well as Hitachi construction machinery ”

André Molenaar, owner, Molenaar Zand en Grond BV

## RENOWNED FOR RELIABILITY

Hitachi construction machinery is renowned worldwide for its reliability to achieve optimum levels of availability and performance, and the new range of compact wheel loaders is no exception. They are able to operate at the highest levels of efficiency, and are easy to maintain thanks to their accessible components.

### Minimal downtime

A 500-hour service interval means that Hitachi compact wheel loaders can work reliably for a lengthy period of time between oil and filter changes. This results in minimal downtime and a high level of availability.

### Quick access

The engine cover is easy to open for convenient access to the engine compartment, the diesel tank and fuel filter. This helps to ensure routine maintenance is completed quickly to ensure a reliable performance.

### Efficient cooling

A temperature-dependent, hydraulically driven engine fan helps to improve fuel

efficiency. For maximum reliability, this can be controlled directly from the cab.

### Easy maintenance

The battery disconnect switch is now included as standard. This helps to avoid electrical accidents during maintenance and retain battery energy during long-term storage.

### Optimum levels of availability

An optional service valve for draining engine and hydraulic oil saves time during routine maintenance, and helps to maximise uptime.



Easy-to-open engine cover provides quick access.



Engine fan helps to reduce emissions and improve fuel efficiency.



Battery disconnect switch for easy maintenance.



High-performance single arm ensures precision.



Internal single arm hosing and wiring protects key components.



**i** Fitted with a Deutz Stage III B-compliant engine, each machine has low-maintenance requirements and is exceptionally reliable with a 500-hour engine service interval.



# DESIGNED FOR DURABILITY

Hitachi's market-leading reputation for the toughest construction machinery continues with the new range of compact wheel loaders. Designed and engineered to operate across a wide range of demanding job sites, the ZW65-6, ZW75-6 and ZW95-6 are the epitome of durability.



## Powerful performance

The overall design of the new compact wheel loaders is highly durable. It incorporates a high-performance single arm with a low-torsion, rigid profile. Less torsion on the boom results in greater precision during levelling.

## Increased protection

The single arm's hosing and wiring are located internally, which provides protection for vital components. This not only enhances the machine's lifespan, but also increases safety and productivity on the job site.



## Excellent stability

The electro-hydraulically operated quick coupler enables the fast and easy connection of attachments. This also helps to improve safety, as less manual input is required, and enhances overall efficiency.

## Reduced costs

Additional durability is ensured by the separation of connection and turning points on the new quick coupler. This also results in reduced maintenance costs.

Durable quick coupler reduces maintenance costs.



“ *The wheel loader is easy to manoeuvre, with precise and smooth movements* ”

Nazif Orakçi, operator, Dolphin Metal Separation

## OUTSTANDING VERSATILITY

Hitachi compact wheel loaders provide a smooth and efficient operation on a wide range of job sites. Their versatility is underlined by a compact design, ease of use and high level of precision.

### Efficient flexibility

The electro-hydraulically operated quick coupler enables the fast and easy connection of attachments. This also helps to improve safety, as less manual input is required, and enhances overall efficiency.

### Easy to transport

Hitachi compact wheel loaders are easy to move between locations on a trailer, with a maximum transportation height of four metres. The ZW65-6 and ZW75-6 models have optional 30km/h travel speeds. This adheres to local legal requirements, further enhancing their versatility.

### Improved visibility

Operators have better visibility of the fork attachment, which enables greater precision

and a higher degree of versatility. It also has a positive effect on safety.

### High productivity

Thanks to a significant loading height, Hitachi compact wheel loaders offer high levels of productivity for a wide range of industry solutions, including general construction work, recycling and agriculture.

### Greater control

An optional HDrive enables the manual adjustment of the engine's rpm setting by a switch. This can be used in combination with a sweeper attachment or compactor plate, for example. It improves precision and accuracy, further enhancing the machine's versatility.



Attachments are fitted safely and easily using the quick coupler.



The optional HDrive improves precision and accuracy.



Loading height suitable for a variety of industry solutions.



Safe and easy access to the cab.



All-round visibility increases safety.

**i** Manufactured in Germany, the Hitachi ZW65-6, ZW75-6 and ZW95-6 have been designed specifically for the European market.



# THE HIGHEST QUALITY

Each new compact wheel loader is rigorously tested to ensure it meets the highest possible standards of performance, reliability and safety. The range is built using high-quality and durable components, and offers operators a user-friendly and comfortable experience.



## Easy access

The door opens 180° and has an additional handle to provide easy and safe access for operators when entering the cab.

## Excellent visibility

The 360° panoramic view from the spacious cab helps to create a comfortable working environment, and also helps to increase safety and productivity.

## Longer lifespan

The two-sided bearing on the monoboom is of the highest quality. This helps to improve performance and has a positive effect on the overall longevity of the components.

## Improved comfort

The controls are ergonomically designed for improved productivity and operator comfort. An optional advanced sound system, comfortable seat and large storage space contribute to the ideal workspace.

## User-friendly operation

The easy-to-use joystick is equipped with a speed selector for fast and slow options, quick-coupler control and push buttons for 100% differential lock in both axles.



User-friendly controls enhance operator comfort.



“ Our new compact wheel loaders provide the best technology in this market sector ”

Vasilis Drougkas, Wheel Loader Product Specialist,  
Hitachi Construction Machinery (Europe) NV

## SUPERIOR TECHNOLOGY

The advanced technology incorporated within the design of the ZW65-6, ZW75-6 and ZW95-6 has been developed to meet the ever-changing needs of the construction industry. Every component has been built to maximise performance and offer a superior operating experience.

### Reduced maintenance

A Deutz Stage IIIB-compliant engine contains a cooled exhaust gas recirculation (EGR) system, common rail technology and a diesel oxidation catalyst (DOC). This leading technology helps to reduce maintenance requirements and eliminates regeneration cycles.

### Saving costs

The new state-of-the-art drivetrain offers maximum propulsion force and improved levels of serviceability. This feature also helps to minimise downtime and reduce running costs.

### Optimum performance

Hitachi compact wheel loaders are fitted with a multifunctional display that shows useful information and status updates at a glance. This helps to make maintenance easier and ensures an optimum performance.

### Increased productivity

Powerful Z-kinematics ensure a higher dumping speed and optimal pull-out force. This example of advanced technology improves performance and increases productivity.



Maintenance requirements are reduced by the new engine.



Multifunctional display is easy to view in the cab.



Powerful Z-kinematics help to increase productivity.



Mini excavators



Compaction equipment



ZAXIS excavators





“ We develop construction machinery that contributes to the creation of affluent and comfortable societies ”

Yuichi Tsujimoto, HCM President

## BUILDING A BETTER FUTURE

Established in 1910, Hitachi, Ltd. was built upon a founding philosophy of making a positive contribution to society through technology. This is still the inspiration behind the Hitachi group's reliable solutions that answer today's challenges and help to create a better world.

Hitachi, Ltd. is now one of the world's largest corporations, with a vast range of innovative products and services. These have been created to challenge convention, improve social infrastructure and contribute to a sustainable society.

Hitachi Construction Machinery Co., Ltd. (HCM) was founded in 1970 as a subsidiary of Hitachi, Ltd. and has become one of the world's largest construction equipment suppliers. A pioneer in producing hydraulic excavators, HCM also manufactures wheel loaders, rigid dump trucks, crawler cranes and special application machines at state-of-the-art facilities across the globe.

Incorporating advanced technology, Hitachi construction machinery has a reputation for the highest quality standards. Suitable for a wide range of industries, it is always hard at

work around the world – helping to create infrastructure for a safe and comfortable way of living, developing natural resources and supporting disaster relief efforts.

Hitachi wheel loaders are renowned for being reliable, durable and versatile – capable of delivering the highest levels of productivity under the most challenging of conditions. They are designed to provide owners with a reduced total cost of ownership, and operators with the ultimate level of comfort and safety.



Wheel loaders

# SPECIFICATIONS

	ZW65-6	ZW75-6	ZW95-6
Operating weight	4,710 kg	5,050 kg	5,410 kg
Engine power	50 kW (68 hp)	50 kW (68 hp)	55.4 kW (75 hp)
Bucket capacity	0.70 – 1.20 m <sup>3</sup>	0.85 – 1.50 m <sup>3</sup>	1.00 – 1.60 m <sup>3</sup>

- Monoboom with hydraulic quick-coupler
- Powerful Z-kinematics
- Self-stabilising concept
- Panorama cab with removable cabin roof
- Power controlled, high performance hydrostatic drive
- Planetary axles with manually switched, 100% differential lock on front and rear axle
- Smooth joystick operation
- Extensive range of attachments

Engine	ZW65-6	ZW75-6	ZW95-6
Model	Deutz		
Type	Low noise water-cooled 2.9 L4 turbo		
Net power	2,300 rpm		
acc. to ISO 14396	68 hp/50 kW	68 hp/50 kW	75 hp/55.4 kW
Max torque at	1,800 rpm		
acc. to ISO 14396	234 Nm	234 Nm	260 Nm
Air intake filter	2 level dry air filter with safety cartridge		
<b>Electrical system</b>			
Operating voltage	12 Volt		
Battery capacity	100 Ah		
Alternator rating	95 A		

Drive	ZW65-6	ZW75-6	ZW95-6
Axles	Large-scale production planetary axles		
Differential lock	Manually switched differential lock in both axles with 100% lock		
Wheels tyre size	12.5-18	12.5-18	365/70 R18
Option	365/70 R18	405/70 R18	405/70 R18
Speeds: road gear	0-20 km/h		
Field gear	0-7 km/h		
Oscillation angle	+/- 11°		

Brakes	ZW65-6	ZW75-6	ZW95-6
Service brakes	Hydrostatic inching brake, acting on all four wheels. Hydraulically operated disc brake at the front axle, acting on all four wheels		
Parking brakes	Mechanically activated parking brake, acting on all four wheels, with deactivation of the drive		

Steering	ZW65-6	ZW75-6	ZW95-6
	Hydrostatic articulated steering		
Max. steering angle	2 x 40°		
Turning radius over rear	RK = 3,700mm		

Hydraulic system	ZW65-6	ZW75-6	ZW95-6
	Single circuit hydraulics with central gear pump		
	Max. power at 2,300 rpm 62 l/min and 250 bar		
	Floating position for lifting cylinders		
2 lifting cylinders	70 ø	80 ø	
1 tilting cylinder	90 ø	100 ø	

Filling capacities	ZW65-6	ZW75-6	ZW95-6
Engine with filters approx	8.0 l		
Fuel tank approx	87.0 l		
Front axle total approx	5.9 l		
Rear axle total approx	6.8 l		
Hydraulic system incl. tank approx	60 l		

Performance data	ZW65-6	ZW75-6	ZW95-6
Bucket position	Crowd angle 47% dump angle top max 45%		
Lifting force at ground	3,500 daN	4,300 daN	4,300 daN
Breakout force	3,500 daN	4,200 daN	4,000 daN
Thrust force	3,800 daN	3,800 daN	4,100 daN
<b>Tipping load<sup>1</sup></b>			
Standard bucket, straight	3,220 kg	3,700 kg	4,100 kg
Standard bucket, articulated	2,900 kg	3,300 kg	3,680 kg
<b>Payload machine<sup>2</sup></b>	Even ground		
On forks, frontal	2,100 kg	2,350 kg	2,610 kg
On forks, articulated	1,900 kg	2,100 kg	2,350 kg

<sup>1</sup> TIPPING LOAD ACCORDING TO ISO 14397 <sup>2</sup> PAYLOAD ACCORDING TO EN 474-3

Emissions	ZW65-6	ZW75-6	ZW95-6
	Engine according to EU 97/68 Stage IIIB		
<b>Noise emission</b>			
Sound power level (LWA) <sup>1</sup>	99 dB(A)		
Acoustic power level (LpA) <sup>2</sup>	75 dB(A)		
<b>Vibrations</b>			
Vibration total value <sup>3</sup>	< 2.5 m/s <sup>2</sup>		
Effective vibration level <sup>4</sup>	< 0.5 m/s <sup>2</sup>		

<sup>1</sup> According to 2000/14/EG <sup>2</sup> According to ISO 6396  
<sup>3</sup> According to ISO/TR 25398 <sup>4</sup> According to ISO/TR 25398

Standard features	ZW65-6	ZW75-6	ZW95-6
Comfortable panoramic cab with ROPS and removable top	●	●	●
Driver door opens through 180°	●	●	●
Right side window opens through 180° – can be locked in two positions	●	●	●
Single-piece floor mat for easy cleaning	●	●	●
Tinted windows	●	●	●
Parallel guided windscreen wiper	●	●	●
Rear wiper	●	●	●
Front and rear screen washing device	●	●	●
Heated rear window	●	●	●
Two fold away outside mirrors	●	●	●
Tinted roof window	●	●	●

Standard features	ZW65-6	ZW75-6	ZW95-6
Steering column is adjustable in inclination	●	●	●
Ergonomic joystick control	●	●	●
Multiply adjustable driver's seat	●	●	●
Safety belt	●	●	●
Sunshade	●	●	●
Heating and ventilation system with recirculation air function	●	●	●
Main battery switch	●	●	●
Interior light	●	●	●
12 V socket	●	●	●
Coat hook	●	●	●
Storage pockets in the cabin	●	●	●
Intuitive modular control panel with onboard computer for machine monitoring	●	●	●
Two driving lights	●	●	●
Single-key system	●	●	●
1st proportional auxiliary circuit for quick-coupler	●	●	●
Hydraulic brand compatible quick-coupler with electric safety device	●	●	●
Towing coupling	●	●	●
Fastening and lifting points	●	●	●

Optional equipment	ZW65-6	ZW75-6	ZW95-6
30 km/h version	○	○	
Variety of tyres	○	○	○
DPF filter	○	○	○
Engine 55 kW (75 HP)		○	
Beacon light	○	○	○
Interior mirror	○	○	○
Acoustic back-up alarm	○	○	○
FOPS grid for cabin roof	○	○	○
Bucket protection cover compliant with road-safety standards	○	○	○
Hydraulic hoses for 1st auxiliary circuit	○	○	○
Permanent function for auxiliary hydraulics	○	○	○
Safety valves	○	○	○
Boom suspension	○	○	○
Bio-degradable oil fill for hydraulic system	○	○	○
Pressureless return line	○	○	○
HDRIVE (hand throttle + inching mode on pedal)	○	○	○
Air-suspended driver's seat	○	○	○
Glove-box with lid	○	○	○
Radio	○	○	○
Immobiliser	○	○	○
Two working rear lights	○	○	○
Cyclonic filter	○	○	○
Corrosion protection for salt applications	○	○	○

## ZW65-6 dimensions

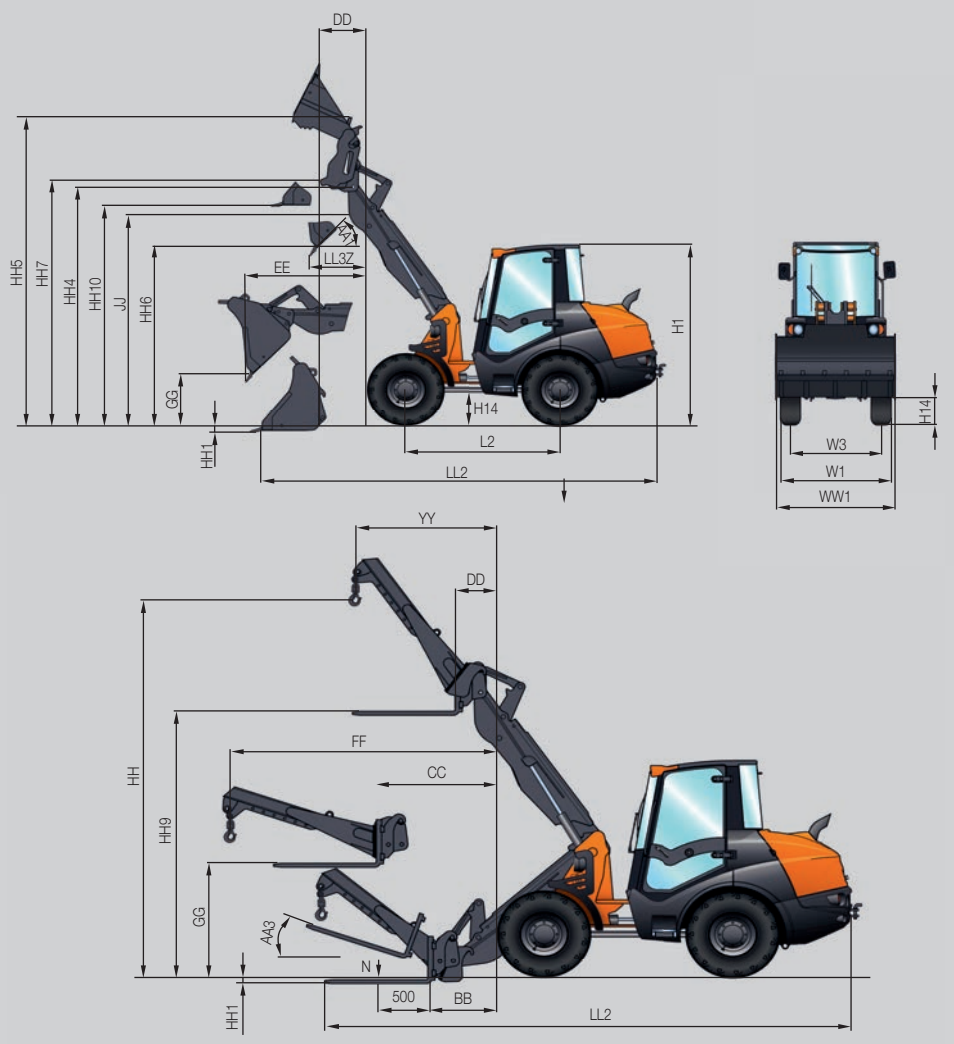

Buckets		
Standard 0.7 m <sup>3</sup>	4 x 1 (0.65 m <sup>3</sup> )	
AA1	45°	42°
DD		535
EE	1,550	1,625
GG	735	595
H1	2,470	2,470
H4	340	340
H14	420	420
HH1	90	105
HH4	3,275	3,275
HH5	4,150	
HH6	2,475	2,375
HH7		3,010
HH10	3,030	3,010
JJ	2,780	2,770
L2	2,030	2,030
LL2	5,285	5,475
LL3 Z	780	880
W1	1,600	1,600
W3	1,315	1,315
WW1	1,600	1,600

HIGH LIFT		
Buckets		
Standard 0.7 m <sup>3</sup>	4 x 1 (0.65 m <sup>3</sup> )	
Density 1.4 t/m <sup>3</sup>		
HH6	2,785	2,685
Forks		
Forks	Load hook	
AA3	19°	
BB	1,085	
CC	1,315	
DD	410	
FF		2,850
GG	1,385	
HH		4,510
HH1	100	
HH9	3,050	
LL2	5,730	6,385
YY		1,240

# SPECIFICATIONS

## ZW75-6 dimensions

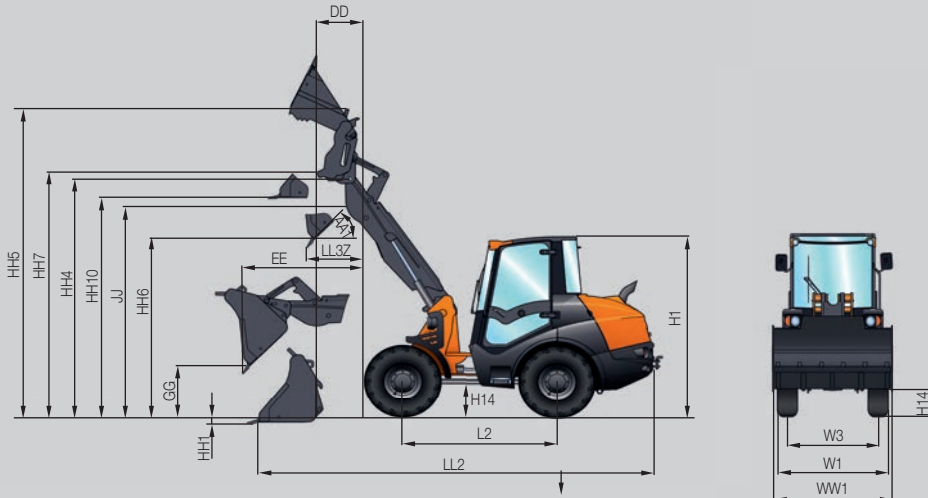

Buckets		
	Standard 0.85 m <sup>3</sup>	4 x 1 (0.80 m <sup>3</sup> )
AA1	45°	42°
DD		535
EE	1,590	1,625
GG	760	595
H1	2,470	2,470
H4	340	340
H14	420	420
HH1	90	105
HH4	3,275	3,275
HH5	4,150	
HH6	2,475	2,375
HH7		3,010
HH10	3,030	3,010
JJ	2,780	2,770
L2	2,030	2,030
LL2	5,285	5,475
LL3 Z	780	880
W1	1,750	1,750
W3	1,405	1,405
WW1	1,850	1,950

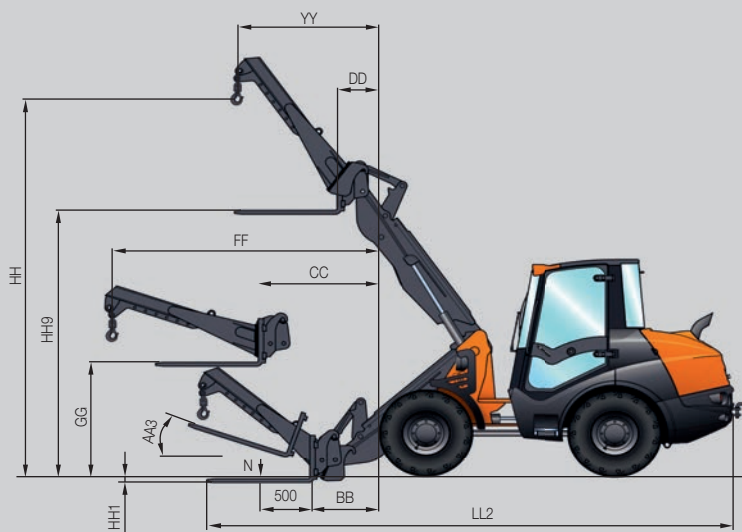

HIGH LIFT		
	Standard 0.85 m <sup>3</sup>	4 x 1 (0.80 m <sup>3</sup> )
Density 1.4 t/m <sup>3</sup>		
HH6	2,785	2,685

	Forks	Load hook
AA3	19°	
BB	1,085	
CC	1,315	
DD	410	
FF		2,850
GG	1,385	
HH		4,510
HH1	100	
HH9	3,050	
LL2	5,730	6,385
YY		1,240

## ZW95-6 dimensions

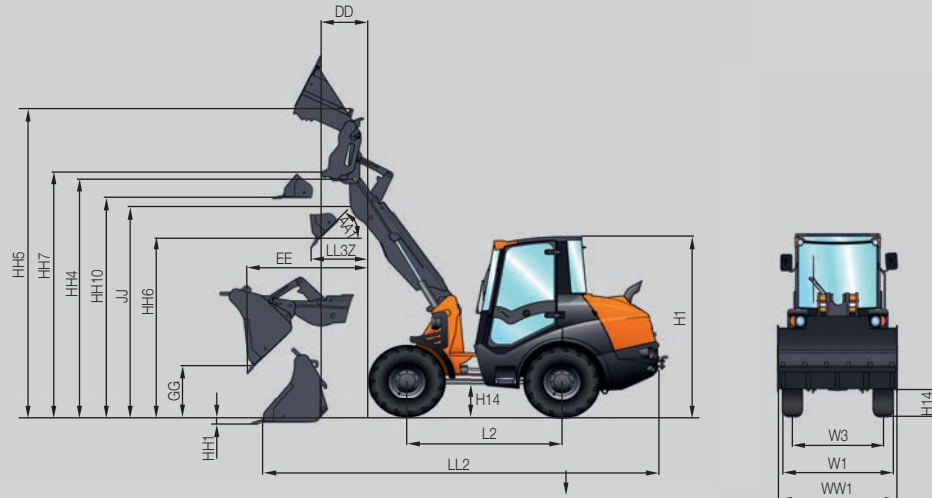

Buckets		
	Standard 1.00 m <sup>3</sup>	4 x 1 (0.95 m <sup>3</sup> )
AA1	45°	42°
DD		535
EE	1,650	1,785
GG	700	515
H1	2,440	2,440
H4	325	325
H14	415	415
HH1	100	140
HH4	3,270	3,270
HH5	4,250	
HH6	2,400	2,280
HH7		2,980
HH10	3,015	2,980
JJ	2,780	2,770
L2	2,030	2,030
LL2	5,350	5,595
LL3 Z	850	1,030
W1	1,750	1,750
W3	1,405	1,405
WW1	1,850	1,950

### HIGH LIFT

Buckets		
	Standard 1.0 m <sup>3</sup>	4 x 1 (0.95 m <sup>3</sup> )
Density 1.4 t/m <sup>3</sup>		
HH6	2,710	2,590

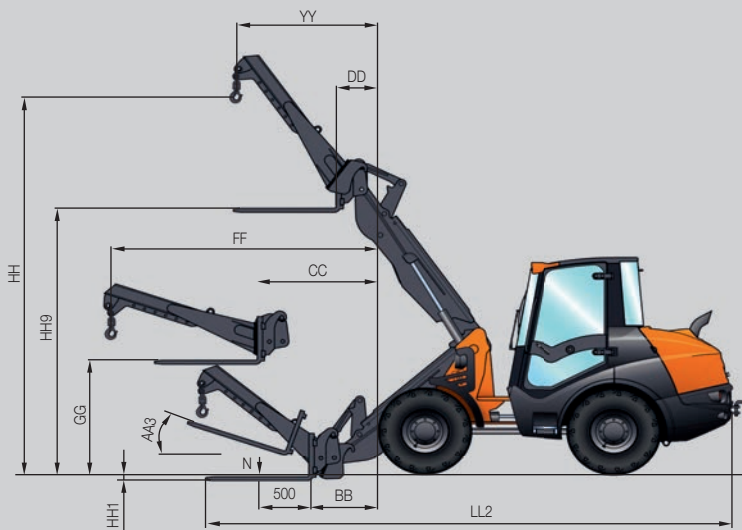

	Forks	Load hook
AA3	19°	
BB	1,100	
CC	1,365	
DD	435	
FF		2,865
GG	1,355	
HH		4,510
HH1	95	
HH9	3,065	
LL2	5,730	6,385
YY		1,240





Prior to operating this machine, including satellite communication system, in a country other than a country of its intended use, it may be necessary to make modifications to it so that it complies with the local regulatory standards (including safety standards) and legal requirements of that particular country. Please do not export or operate this machine outside the country of its intended use until such compliance has been confirmed. Please contact your Hitachi dealer in case of questions about compliance.

These specifications are subject to change without notice. Illustrations and photos show the standard models, and may or may not include optional equipment, accessories, and all standard equipment with some differences in color and features. Before use, read and understand the Operator's Manual for proper operation.

