

Engine	Cummins 6LT9.3
Gross Power	162 kW (220 hp) @ 2,200 rpm
Net Power	148 kW (201 hp) @ 2,200 rpm
Operating Weight	16,700 kg
Standard Bucket Size	3 m <sup>3</sup>
Standard Breakout Force	167 kN
Standard Dump Clearance	2,970 m

# ZL50CNX WHEEL LOADER



TOUGH WORLD. TOUGH EQUIPMENT.

# ZL50CNX SPECIFICATIONS >>>

## ENGINE

Emission Regulation	Tier 2 / Stage II
Make	Cummins
Model	6LT9.3
Gross Power	162 kW (220 hp) @ 2,200 rpm
Net Power	148 kW (201 hp) @ 2,200 rpm
Peak Torque	890 N · m
Displacement	9.3 L
Number of Cylinders	6
Aspiration	Turbocharged

## TRANSMISSION

Transmission Type	Countershaft, power shift
Torque Converter	Single stage, three elements
Maximum Travel Speed, fwd	40 km/h
Maximum Travel Speed, rev	24.7 km/h
Number of Speeds, fwd	4
Number of Speeds, rev	3

## AXLES

Differential Front Type	Conventional
Differential Rear Type	Conventional
Axle Oscillation	±11°

## STEERING

Steering Configuration	Articulated
Steering Relief Pressure	12 Mpa

## BRAKES

Service Brake Type	Caliper disc brake
Service Brake Actuation	Air over hydraulic
Parking Brake Type	Manual pneumatic control
Parking Brake Actuation	Air

## HYDRAULIC SYSTEM

Main Pump Type	Gear
Main Relief Pressure	17 MPa
Raise	6.5 s
Dump Time	1.5 s
Float Down Time	3.5 s
Fastest Total Cycle Time	11.5 s

## LOADER ARM PERFORMANCE

Tipping Load - Straight	13,414 kg
Tipping Load - Full Turn	11,000 kg
Bucket Breakout Force	167 kN
Maximum Dump Angle at Full Height	45°
Dump Clearance at Full Height Discharge	2,970 mm
Dump Reach at Full Height Discharge	1,200 mm
Maximum Hinge Pin Height	4,020 mm
Maximum Digging Depth, Bucket Level	60 mm
Bucket Rollback at Ground Level	42°
Bucket Rollback at Carry	46°
Bucket Rollback at Maximum Height	59°

## BUCKET PERFORMANCE

Reference Bucket	3 m <sup>3</sup>
------------------	------------------

## DIMENSIONS

Length with Bucket Down	8,030 mm
Width Over Tires	2,750 mm
Wheelbase	3,427 mm
Wheel Tread	2,150 mm
Ground Clearance	485 mm
Turn Angle, Either Side	35°
Rear Angle of Departure	30°
Turning Radius, Outside of Tire	6,647 mm
Turning Radius, Center of Tire	6,347 mm
Turning Radius, Bucket Carry	7,598 mm

## TIRES

Tire Size	23.5 - 25
-----------	-----------

## OPERATING WEIGHTS

Operating Weight	16,700 kg
------------------	-----------

## SERVICE CAPACITY

Fuel Tank	300 L
Engine Oil	18 L
Cooling System	50 L
Hydraulic Reservoir	300 L
Transmission and Torque Converter	45 L
Axles, each	32 L

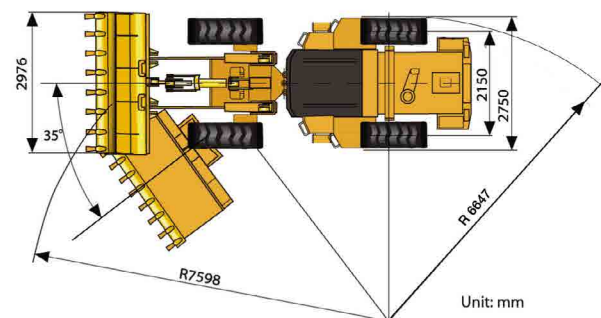
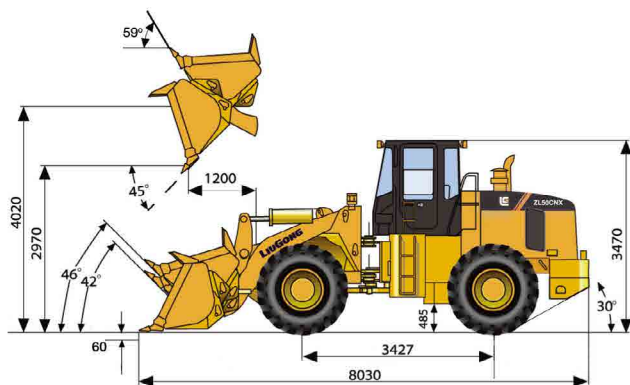

Guangxi Liugong Machinery Co., Ltd.

No. 1 Liutai Road, Liuzhou, Guangxi 545007, PR China  
T: +86 772 3886124 E: overseas@liugong.com  
www.liugong.com

Specifications and designs are subject to change without notice. Machines shown may include optional equipment.

06/2014 Designed by LiuGong