

Specification sheet

XF 450

FA 4X2 Rigid, Low Deck



ENGINES

XF 450 MX-11 (330 kW / 449 hp)
XF 430 MX-13 (315 kW / 428 hp)
XF 480 MX-13 (355 kW / 483 hp)
XF 530 MX-13 (390 kW / 530 hp)

GVM¹⁾

18000 kg

Max. front 7500 kg

Max. rear 11500 kg

GCM²⁾

44000 kg

CAB EXTERIOR

Space Cab with galvanised steel bumper, tinted glass and electric window openers. Main mirrors and wide angle mirrors electrically heated. Cab width 2490 mm.; Cab suspension mechanical; LED daytime running lights; Front view mirror; Central door lock system, 2 keys, 2 RC units.

Optional

01760 Super Space Cab	09982 No auxiliary lights in the bumper
01226 Cab suspension air	09984 Fog lights and cornering lights
01174 External sun visor green translucent	06593 Skylights
00847 Air horns, single set	06628 One hazard beacon light at co-driver side
09006 Air horns, double set	06627 One hazard beacon light at driver side
08020 LED head lights	06629 Two hazard beacon lights

AERODYNAMICS

Optional

08823 Adj. roof air deflector Space Cab; over 4 m (!)	06904 Fixed rf deflector; total height over 4 m
08822 Adj. roof air deflector for Space Cab	04906 Side collars
06160 Fixed roof air deflector for Super Space Cab	

COLOURS

Cab colour H3279 Brilliant White; Head lamp panel and bumper: Brilliant White; Chassis colour grey..

Optional

07801 Cab steps and wing in cab colour	07901 Air intake grid cab colour
---	---

CAB INTERIOR

Cab interior trim colour Dark Sand; Cab interior decoration Piano Black; Driver seat: Comfort Air; Co-driver seat: basic; Lower bunk without drawer; Automatic Temperature Control and aircro; Auxiliary cab heater (water); Pollen filter.

Optional

09271 Steering wheel, leather, colour black	07743 Co-driver seat: Luxury Air
07240 Steering wheel, leather, Exclusive	07746 Co-driver seat: Super Air
07152 Cab interior trim colour Exclusive	07748 Co-driver seat: Xtra Leather Air
07592 Cab interior decoration Argenta	00967 Seat belts red
07591 Cab interior decoration Rustica	06539 Refrigerator
07733 Driver seat: Luxury Air	09603 Lower bunk with drawer 65 litres
07736 Driver seat: Super Air	06784 Lower bunk mattress Xtra Comfort
07737 Driver seat: Xtra Leather Air	06676 PL light in cab ceiling
07741 Co-driver seat: Comfort Air	06970 Automatic Cab Climate Control

COMMUNICATION AND DRIVING MANAGEMENT

Tachograph digital, Stoneridge 1C; Speed limiter setting 85 km/h; Eco off 90 km/h; Antennas: AM/FM, 2x GSM, GPS; Adaptive Cruise Control with FCW and AEBS-CM2.

Optional

09681 Preparation for Maut	07261 TruckPhone
07117 Radio/USB player, 2 speakers	06991 Predictive Cruise Control
01100 Truck Navigation Radio, 6 speakers	

SAFETY AND SECURITY

Lane Departure Warning System; Vehicle Stability Control (VSC); Basic engine immobiliser system.

Optional

08631 Air bag (driver) and 2 seat belt tensioners	09827 Side camera system
07011 DAF Night Lock	01725 Reverse warning
09828 Front camera system	

SUSPENSION AND AXLES

Front axle load 8.00 t; Rear: 11.50 t, air suspension, SR1344.

Optional

04588 Rear axle SR1347	08191 Axle load monitoring
-------------------------------	-----------------------------------

WHEELS AND TYRES

Front axle 1: 315/60R22.5; Rear axle 1: 295/60R22.5; Disc wheels steel, silvergrey; Wheel protection rings silvergrey.

Optional

16152 Tyre makes and types

DRIVELINE

Engine MX-11, multi torque 6 cylinder diesel engine, 10.8 litres. Output 330 kW (449 hp) at 1600 rpm. Maximum torque 2300 Nm at 900-1125 rpm.; Exhaust emission Euro 6; Engine idle shutdown, 5 minutes; Automated gearbox, TraXon, 12 speeds; Gearbox ratio 16.69-1.00; Rear axle ratio 2.05.

Optional

04523 Manual gearbox, 16 speeds	02314 Gearbox overdrive
07103 Automated gearbox, TraXon, 16 speeds	

BRAKE SYSTEM

MX Engine Brake; Ventilated disc brakes front and rear. Dual circuit air system with electronic control (EBS). Twin cylinder air compressor with heated dryer and economy mode..

Optional

09920 No MX Engine Brake	02715 ZF Intarder
---------------------------------	--------------------------

CHASSIS

Wheelbase 4.90 m / rear overhang 2.35 m; Side member height 260 mm; Standard component location; Exhaust pipe horizontal, low; Aluminium fuel tank 450 l, height 505 mm; Spray suppression; Front underrun protection (FUP); Tank for AdBlue® 75 l, left-hand side chassis.

Optional

07071 Spare wheel carrier right-hand side	03323 Rear light with LEDs
--	-----------------------------------

DRAWBAR AND TRAILER EQUIPMENT

D-value cross member D=13.7; Pneumatic trailer connection C-type; Electric connection 24 V / 2x7 pins.

Optional

- 07033** Trailer coupling Ringfeder D=13.7 **08027** Trailer coupling Rockinger D=20.0
07034 Trailer coupling Ringfeder D=20.0 **04659** Trailer cable EBS
08026 Trailer coupling Rockinger D=13.0

BODIES AND PREPARATIONS FOR BODYING

Application connector on the cab front.

Optional

- 06692** Application connector on the chassis **02597** Application connector for tail lift control

POWER TAKE-OFF (PTO)

Optional

- 16148** PTO types and positions

ELECTRICAL POWER SUPPLY

Alternator 80 A, batteries 2x 230 Ah..

Optional

- 06460** Alternator 120 A **07671** Batteries 2x210Ah AGM C-type
08775 Alternator 150 A

GVM AND GCM

Chassis weight related technical GVM max 19500 kg; Driveline related max GCM 50000 kg class 3.

Optional

- 03673** Driveline related max GCM 44000 kg class 2

APPLICATION CONDITIONS

Air intake front.

Optional

- 08400** Silent mode **03648** Cyclonic air intake high
03647 Air intake high

SERVICE AND MAINTENANCE

Standard Warranty takes care of 1 year complete vehicle, 2nd year driveline and 1st year breakdown.; ITS service.

Optional

- 08311** Service interval extended



Go to [DAF.com](https://www.daf.com) to configure your own perfect DAF.

XF 450

FA 4X2 Rigid, Low Deck

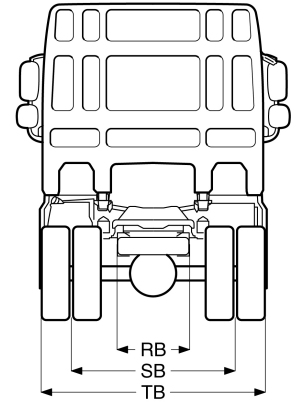
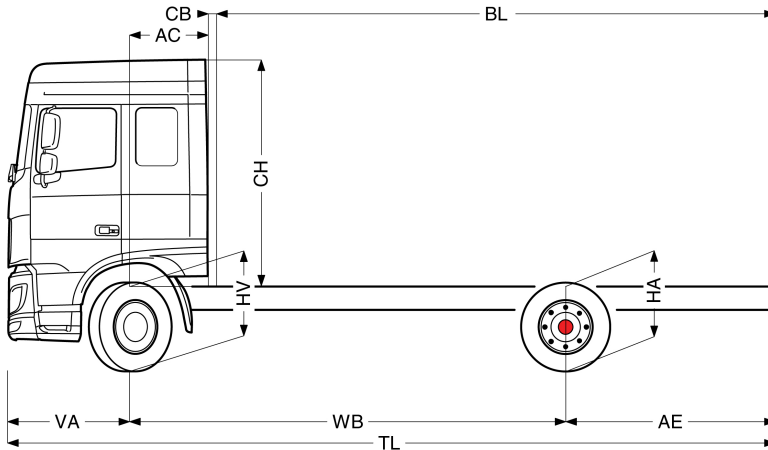

	Wheelbase - AE		Unladen weight ⁹⁾			Gross Carrying Capacity			Variable dimensions									
	WB	AE ⁵⁾	Front	Rear	Total	Front	Rear	Total	AC	CB ⁶⁾	CH ⁷⁾	BL ⁸⁾	BL	TL	HA ⁹⁾	HA ¹⁰⁾	TK ¹¹⁾	TW ¹²⁾
SPACE CAB	4.90	2.35	5248	2197	7444	2252	9303	10556	0.88	0.10	2.56	5.75	6.67	8.62	0.89	0.87	16.34	17.75
	5.40	2.65	5241	2248	7489	2259	9252	10511	0.88	0.10	2.56	6.53	7.54	9.42	0.89	0.87	17.65	19.07
	5.70	2.85	5282	2351	7633	2218	9149	10367	0.88	0.10	2.56	7.00	8.09	9.92	0.89	0.87	18.43	19.87
	6.10	3.10	5286	2402	7688	2214	9098	10312	0.88	0.10	2.56	7.64	8.79	10.57	0.89	0.87	19.48	20.92
SUPER SPACE CAB	4.90	2.35	5312	2195	7507	2188	9305	10493	0.88	0.10	2.94	5.80	6.73	8.62	0.89	0.87	16.34	17.75
	5.40	2.65	5305	2247	7552	2195	9253	10448	0.88	0.10	2.94	6.58	7.60	9.42	0.89	0.87	17.65	19.07
	5.70	2.85	5346	2351	7696	2154	9149	10304	0.88	0.10	2.94	7.06	8.15	9.92	0.89	0.87	18.43	19.87
	6.10	3.10	5350	2401	7751	2150	9099	10249	0.88	0.10	2.94	7.69	8.87	10.57	0.89	0.87	19.48	20.92

OTHER DIMENSIONS	VA: 1.37	HV ¹³⁾ : 0.89	HV ¹⁴⁾ : 0.88	RB: 0.79	SB: 1.82	TB ¹⁵⁾ : 2.46
------------------	----------	--------------------------	--------------------------	----------	----------	--------------------------

1) GVM in conformity with registration documents.

2) GCM in conformity with registration documents.

3) Axle load with standard tyre size.

4) Chassis and cab weight calculated with: Standard specification items only with 450 litres of fuel, 75 litres of AdBlue® and driver of 90 kg, tolerance ± 3%. Changing of the specification can have major impact on vehicle weight.

5) Other AE dimensions may be available for shown WB. Modify rear overhang to the calculated body length.

6) CB is based on standard air intake and/or exhaust.

7) Cab height is measured from frame member to closed cabin roof hatch.

8) Calculate customer specific body length with TOPEC. Body lengths shown based on evenly distributed load at max axle load.

9) Unladen height at centre of driven axle(s).

10) Laden height at centre of driven axle(s).

11) TK = turning circle between kerbs.

12) TW = turning circle between walls.

13) Unladen height at centre of front axle(s).

14) Laden height at centre of front axle(s).

15) TB is overall width at rear. (At centre of front axle 255).

Depending on the vehicle configuration a specific option may not be possible. The availability and specification of this vehicle may differ per country. For further information please contact the DAF organisation. Pictures and technical illustrations are not binding in detail and can differ from the standard specification. Subject to modification without prior notice.