

# KOMATSU®

## WB146-5 WB146PS-5

**NET HORSEPOWER**  
66 kW **88 HP** @ 2200 rpm

**OPERATING WEIGHT**  
7300 kg **16,090 lb**

**WB**  
**146**



Photos may include optional equipment

BACKHOE LOADER

# WALK-AROUND

*The Dash 5 Komatsu Backhoe Loaders* include the best from our previous series and add innovations for the future. The WB146-5 has the power, speed, balance, control, and operator comfort to be extremely productive in a very competitive world.

***Spacious and comfortable operator station*** allows 360° visibility. Adjustable seat, steering, and backhoe controls allow the machine to better fit any operator. Switches and gauges are clustered to simplify operation.

***Corner mounted*** exhaust enhances visibility.

***Tilting engine hood*** can be opened when the loader is in the raised or lowered position.

***Powerful engine and hydraulics***

66 kW **88 HP** engine combined with Komatsu's HydraMind hydraulic system provides fast, precise, and comfortable operation. Two working modes allow the operator to choose between maximum power and minimum fuel consumption.

***Dual direction parallel lift loader linkage*** keeps the bucket or forks near level throughout the lifting arc.

***Heavy-duty cast nose guard*** provides integral counterweight and front protection to the engine compartment.

***Large loader bucket***

0.95 m<sup>3</sup> **1.25 yd<sup>3</sup>** loader bucket with bolt-on cutting edge.

***Steering Cylinders***

are mounted behind and above the front axle for protection from jobsite debris.



**NET HORSEPOWER**  
66 kW **88 HP** @ 2200 rpm

**OPERATING WEIGHT**  
7300 kg **16,090 lb**

**Front roof** cutout provides a better view of loader at full height.



Photos may include optional equipment

**Telescopic arm** option increases dig depth to 5533 mm **18'2"**.

**S-Boom design** provides superior visibility and helps the operator avoid obstructions when digging or loading trucks.

**Dual tapered backhoe buckets** are equipped with Extreme Service (XS) adapters and teeth (optional).

**Reversible outrigger pads** accommodate both earth and paved surfaces.

**Heavy-duty power shuttle transmission and axles**

Optional PowerShift (WB146PS-5) for shift-on-the-fly with column-mounted lever.

**Large, lockable toolbox** located under step.

# DASH-5 FEATURES



### Tilting Steering Column

The steering column has a single lever that locks when released at the desired position.



### Excavator Controls

Mounted on tilting towers with changeable control pattern.



### Adjustable Wrist Rests

Maximizes ergonomics and operator comfort.



### Pilot Actuated Loader Joystick

Multi-function controls for loader, differential lock, declutch, speed-up, and optional 4-in-1 bucket control.

**Clustered gauges and switches** are in plain view and easy to reach.



### Pilot Actuated Outrigger Levers

Provide smooth and precise control.



### Corner Exhaust/Front Roof Cut-out

Provide an unobstructed view even when loader bucket is at full height.



### S-Shape Backhoe

Enhances truck loading, improves visibility, provides strong breakout and lift capacities.



### Dual Direction Parallel Lift

Mechanical linkage design keeps the load near level from bottom to top (max 11° tilt back).



**Heavy Duty Buckets** include XS adapter system.



### Tiltable Engine Hood

Allows access to service check points. Locks with the ignition key.



### Lockable Toolbox

Secure storage for tools, grease gun, etc.

# OPERATOR STATION



The Dash-5 operator station is state-of-the-art. Interior appointments are rugged. The multiple seat and control adjustment mechanisms enable a better fit for both large and small operators and provide hours of comfortable operation. The canopy, or cab, has a true double-entry

platform. The climate controlled cab is quiet and has 10 vents for excellent air circulation. The cab's rounded shape provides a spacious and quiet environment. Visibility is unsurpassed. The one-piece rear window is easy and quick to open and close.

# WB146-5/WB146PS-5 BACKHOE LOADER

## SPECIFICATIONS



### ENGINE

Model .....Komatsu S4D102LE-2  
 Type .....Vertical, 4-cycle water-cooled diesel engine  
 Aspiration .....Turbocharged  
 Combustion .....Direct injection  
 Compression ratio .....18:1  
 Number of cylinders .....4  
 Piston displacement .....4.5 ltr **275 in<sup>3</sup>**  
 Horsepower rating - **WB146-5/WB146PS-5**  
 Gross horsepower @ 2200 rpm .....69 kW **92 HP**  
 Net horsepower @ 2200 rpm (SAE J 1349) .....66 kW **88 HP**  
 Max torque @ 1500 rpm .....407 Nm **300 ft lb**  
 Air cleaner .....Dry filter with safety element  
 Lubrication system:  
 Method .....Gear pump, force-lubrication  
 Filter .....Full-flow type  
 Air cleaner .....Dry type with double elements and dust evacuator, condition indicator  
 Cooling system .....Radiator  
 Starting system .....Electric motor with air pre-heating system for cold climate



### ELECTRICAL SYSTEM

Electric circuit with protected connections in all exposed areas  
 Voltage .....12 V  
 Battery .....100 Ah (860 CCA)  
 Alternator .....95 A  
 Electric starting .....3.2 kw



### HYDRAULIC SYSTEM

The HydraulMind hydraulic system affords the operator very precise backhoe movements. This system is energy efficient and incorporates two different working modes: economy and constant power. The advanced hydraulic system includes the "speed up" function to increase the working speed of the front loader.

System .....HydraulMind  
 Type .....Closed-center Load Sensing System (CLSS) with economy/power selector switch (power mode is the default)  
 Pump type .....Variable displacement axial piston  
 Pump control system .....Load sensing  
 Main valve ..... "Load Independent Flow Divider" LIFD modular type  
 Max delivery .....165 ltr/min **43.6 gal/min**  
 Working pressure .....245 bar **3,553 psi**



### SERVICE REFILL CAPACITIES

Engine oil .....9 ltr **2.4 U.S. gal**  
 Cooling system .....14 ltr **3.7 U.S. gal**  
 Diesel tank .....150 ltr **39.6 U.S. gal**  
 Hydraulic oil tank .....41 ltr **10.8 U.S. gal**  
 Hydraulic oil system capacity .....97 ltr **25.6 U.S. gal**  
 Front axle oil .....7.5 ltr **2.0 U.S. gal**  
 Rear axle oil .....14.5 ltr **3.8 U.S. gal**  
 Gearbox oil, Power Shuttle .....20.2 ltr **5.3 U.S. gal**  
 Gearbox oil, Power Shift .....28.0 ltr **7.4 U.S. gal**



### STEERING

The front steering wheels are controlled by a hydrostatic load sensing steering priority valve system. Minimum turning radius at the outer edge of front tire:  
 Without brakes .....4000 mm **13'1"**  
 With brakes .....3400 mm **11'2"**



### TRANSMISSION

**WB146-5**  
 Shifting between 2WD and 4WD is achieved through an electro-hydraulic system. The transmission is operated through a torque converter and a power shift reversing shuttle; the mechanical 4-speed gearbox is synchronized

Travel Speeds	1st		2nd		3rd		4th	
	km/h	mph	km/h	mph	km/h	mph	km/h	mph
Forward	6.3	3.9	11.4	7.1	21.3	13.2	37.8	23.5
Reverse	6.3	3.9	11.4	7.1	21.3	13.2	37.8	23.5

### WB146PS-5

Electronically-controlled, four-wheel drive, full powershift transmission. Twist Grip or EGM™ (Electronic Gear Management) gear controls for changing driving direction and gears at full power without disengaging the drive. **Twist Grip Controls** in manual mode.

Travel Speeds	1st		2nd		3rd		4th	
	km/h	mph	km/h	mph	km/h	mph	km/h	mph
Forward	6.5	4.0	12.0	7.5	23.0	14.3	40.0	24.9
Reverse	6.5	4.0	12.0	7.5	23.0	14.3	—	—



### AXLES

Heavy duty axles with planetary reduction gears in the wheel hubs. Front axle total oscillation angle is 20°. Differential lock in the rear axle controlled by electro-hydraulic system with a switch on loader lever.  
 Maximum front strength (Dynamic) .....9800 daN **22,031 lb**  
 Maximum front strength (Static) .....23750 daN **53,392 lb**  
 Maximum rear strength (Dynamic) .....7500 daN **16,861 lb**  
 Maximum rear strength (static) .....18750 daN **42,152 lb**



### BRAKES

Oil immersed disc brakes are actuated by individual braking on each rear wheel with two separate pedals. Total integral braking on the 4 wheels is activated by operating the two pedals at the same time.  
 Disc diameter .....300 mm **11.8"**



### CAB

ROPS and FOPS Level 2 cab designed to offer the best visibility, ergonomics, low noise, and operator comfort. Two doors, full opening rear window with front and rear windshield wipers. Interior features include a fully adjustable seat, fresh filtered air intake ventilation, and easy to reach front and side dash boards.



## LOADER

The design of the front loader allows for better tensile strength distribution and parallel movements when raising and lowering the bucket. Due to the linkage geometry, the number of greasing points has been dramatically reduced.

Standard bucket width . . . . . 2356 mm **7'9"**  
 Standard bucket capacity (SAE) . . . . . 0.95 m<sup>3</sup> **1.25 yd<sup>3</sup>**  
 Standard bucket weight . . . . . 454 kg **1,000 lb**  
 Lifting capacity at maximum height . . . . . 3900 kg **8,598 lb**  
 Lifting capacity at ground level . . . . . 5000 kg **11,020 lb**  
 Breakout force . . . . . 6000 kg **13,224 lb**



## BACKHOE

The boom has a rounded profile and reinforced structure built with cast ends allowing for 180° rotation while maintaining high rotation torque.

Bucket breakout force (ISO 6015) . . . . . 6126 kg **13,505 lb**  
 Arm breakout force (ISO 6015) . . . . . 4005 kg **8,830 lb**

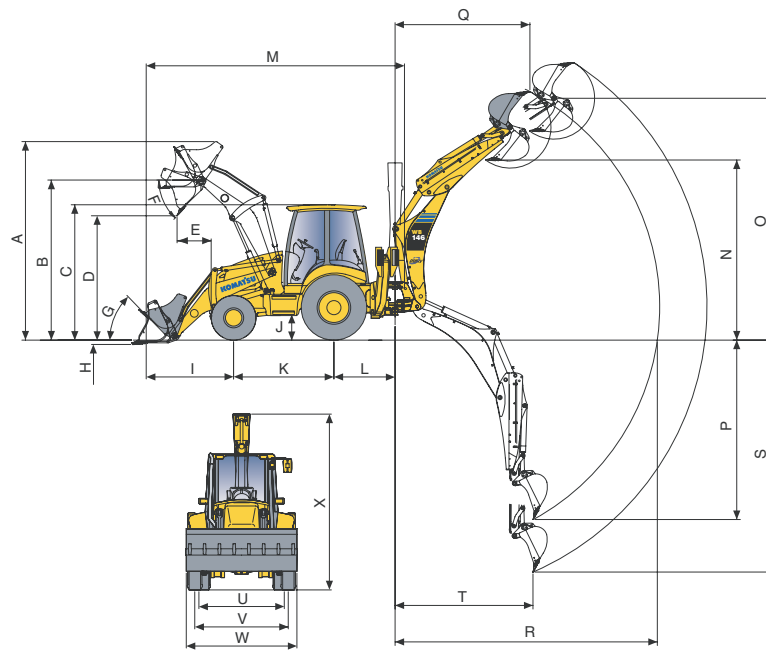

A	Maximum height	4230 mm	<b>13'11"</b>
B	Hinge pin height	3367 mm	<b>11'1"</b>
C	Overall height, ROPS Cab	2935 mm	<b>9'8"</b>
D	Maximum dumping height	2622 mm	<b>8'7"</b>
E	Reach at maximum height and 45° dump angle	750 mm	<b>2'5"</b>
F	Dumping angle	45°	
G	Rollback angle	45°	
H	Digging depth	138 mm	<b>5.4"</b>
I	Bucket reach (transport)	2023 mm	<b>6'8"</b>
J	Ground clearance	430 mm	<b>1'5"</b>
K	Wheel base	2175 mm	<b>7'2"</b>
L	Backhoe swing center distance	1175 mm	<b>3'10"</b>
M	Transportation length	7432 mm	<b>24'5"</b>
N	Dumping height (SAE)	3676 mm	<b>12'1"</b>
	- with retracted telescopic	3658 mm	<b>12'0"</b>
	- with extended telescopic	4369 mm	<b>14'4"</b>

O	Maximum digging height	5319 mm	<b>17'5"</b>
	- with extended telescopic	5885 mm	<b>19'4"</b>
P	Digging depth (2' level bottom)	4370 mm	<b>14'4"</b>
	- with extended telescopic	5479 mm	<b>18'0"</b>
Q	Reach at maximum height	2828 mm	<b>9'3"</b>
	- with extended telescopic	3877 mm	<b>12'9"</b>
R	Maximum reach from swing center	5742 mm	<b>18'10"</b>
	- with extended telescopic	6755 mm	<b>22'2"</b>
S	Maximum digging depth	4423 mm	<b>14'6"</b>
	- with extended telescopic	5533 mm	<b>18'2"</b>
T	Digging reach	2320 mm	<b>7'7"</b>
U	Rear tread	1800 mm	<b>5'11"</b>
V	Front tread	1874 mm	<b>6'2"</b>
W	Overall width (with bucket)	2356 mm	<b>7'9"</b>
X	Backhoe transportation height	3676 mm	<b>12'1"</b>
	- with telescopic arm	3746 mm	<b>12'4"</b>



LIFTING CAPACITY

**Standard Arm**

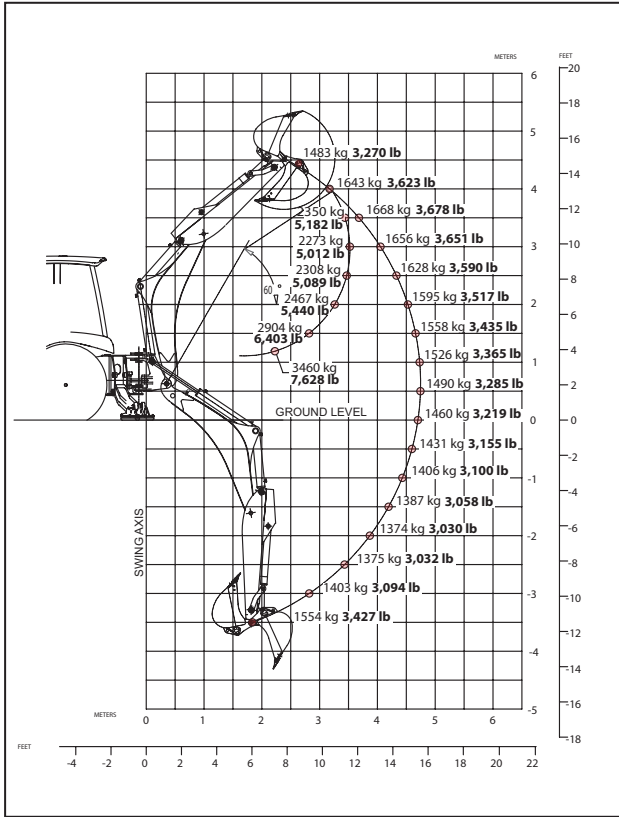

**Retracted Telescopic Arm**

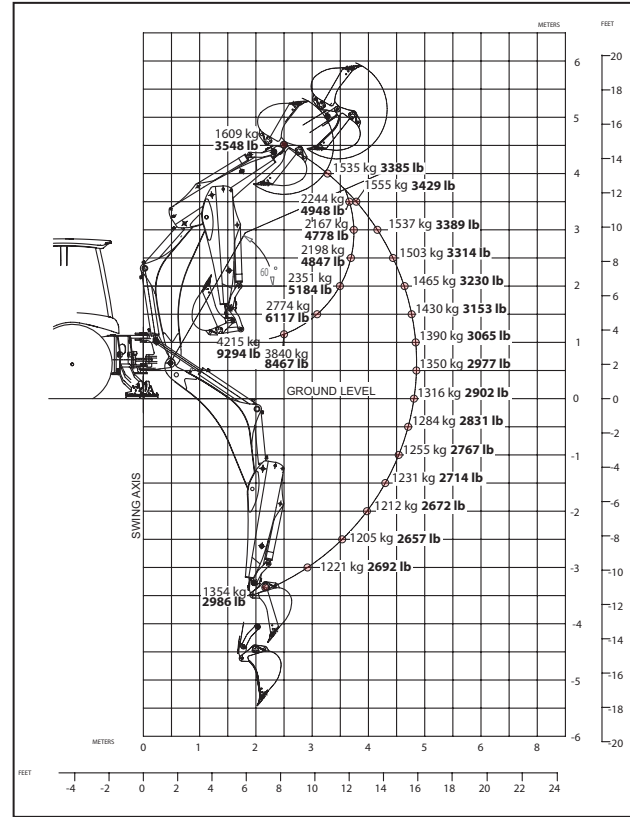

**Extended Telescopic Arm**

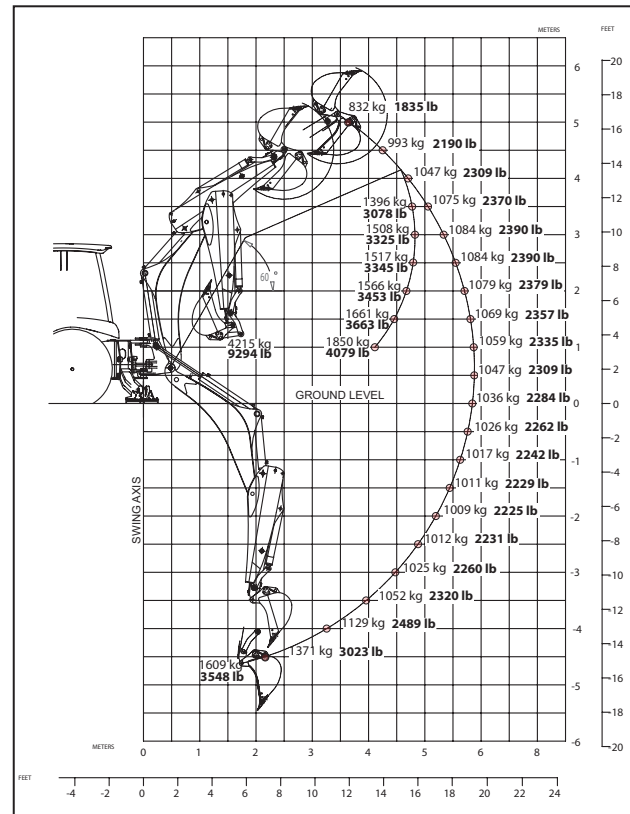





**STANDARD EQUIPMENT**

- Alarm, backup
- Anti-burst/anti-drift valves (outriggers)
- Backhoe, center mount
- Backhoe controls, excavator type
- Battery disconnect switch
- Boom transport & swing lock
- Brakes, wet-disc with dual pedals and lock (4 wheel braking in 4th gear only)
- Cast nose guard/counterweight
- Coat hook (cab only)
- Cup holder (only for a cabin without air-conditioner)
- Differential lock (100% rear axle on demand)
- Drive shaft guard (4-wheel drive only)
- Exhaust in line with ROPS post
- External tool box
- Fan, suction, and fan guard
- Flexible type rear fenders
- Gauges: coolant temperature, fuel level, tachometer, hour meter
- Horn, front, electric
- Horn, rear, electric
- Hydraulic oil cooler, side by side
- Indicators: air cleaner service, engine coolant temperature, engine oil pressure, torque converter oil temperature, 4 wheel drive, low fuel, brake oil level, warning direction indicator, parking brake engagement, brake oil level, differential lock, cold engine preheat, generator warning
- ISO control pattern for backhoe
- Key start/stop system with auxiliary position
- Lamp, overhead for instrument panel (cab only)
- Lift cylinder lock bar
- Lights, working (2 front, 2 rear)
- Loader return-to-dig and float feature
- Mechanical locks, loader control and backhoe control
- Multi-function pilot actuated loader control lever (transmission disconnect, multi-purpose bucket controls, differential lock, loader speed up)
- O-ring face seal hose connections
- Park brake (automatically disengages transmission when activated)
- Powershift transmission (PS model only)
- Power shuttle transmission
- Power socket, 12V for a mobile phone (cab only)
- Rearview mirror (interior - right side mount)
- ROPS and FOPS level 2 Cab with heater (42,320 BTU), air conditioner (31,400 BTU), and fan
- Seat belt, retractable, 76 mm 3" wide
- Seat, mechanical suspension with armrests
- Spin-on fuel, engine oil, hydraulic transmission oil filters and water separator
- Stabilizer pads, flip-over type
- Stop lights and tail lights
- Steering, hydrostatic, load sensing
- Storage compartment, internal
- Throttles, hand and foot
- Tiltable engine hood
- Tires front, 14 x 17.5, 10 ply, R4
- Tires rear, 19.5 x 24, 10 ply, R4
- Transmission disconnect switch on gearshift lever
- Vandalism protection (canopy only)



**OPTIONAL EQUIPMENT**

- Auxiliary hydraulics for hand hammers
- Backhoe auxiliary hydraulics for hydraulic hammers or other unidirectional flow work tool (120 l/min **31.7 gpm**)
- Cold area (-30°C -22°F) arrangement
- High ambient and high altitude package
- High/low beam lights (2 front)
- Hydraulic quick coupler, loader
- Lights, working (4 front, 4 rear)
- Loader auxiliary hydraulics, multi-purpose
- Load stabilizer system (ride control)
- Outrigger cylinder guards
- Pre filter
- Rear view mirrors (exterior - right and/or left mount)
- ROPS and FOPS Level 2 canopy



**AVAILABLE ATTACHMENTS**

- Couplers (front & rear)
- Buckets (range)
- Hydraulic breakers
- Brooms / sweeper
- Compaction plate — hydraulic
- Compaction wheels
- Auger drives



This specification sheet may contain attachments and optional equipment that are not available in your area. Please contact your local Komatsu distributor for those items you may require. Materials and specifications are subject to change without notice.

KUSS184-01

©2008 Komatsu Printed in USA

DK06(5M)C

06/08 (EV-1)

**KOMATSU**<sup>®</sup>

[www.KomatsuAmerica.com](http://www.KomatsuAmerica.com)

Komatsu America Corp. is an authorized licensee of Komatsu Ltd. Materials and specifications are subject to change without notice  
**KOMATSU** is a registered trademark of Komatsu Ltd., Japan