

WA450-1

WHEEL LOADER



ROPS canopy and steel cab are options.
Photo shown may include other optional equipment.

KOMATSU VANGUARD SERIES

- *Komatsu-built components throughout the machine assure years of reliability and high-performance service.*
- *Fingertip control with a smooth, electrically controlled transmission provide high maneuverability.*
- *A tiltable steering wheel and an optional, fully adjustable suspension seat offer ideal conditions for every operator.*
- *An electronic display and monitoring system allows monitoring from the operator's compartment.*
- *The electric system for safety promotes foolproof operation.*
- *Wet disc brakes ensure highly reliable operation.*
- *Torque proportioning differentials minimize tire slippage for extended tire life.*
- *Outstanding performance boosts productivity.*

Flywheel horsepower: 237 HP (177 kW) at 2200 RPM Bucket capacity: 3.5 m³ (4.6 cu. yd)

Operating weight: 19225 kg (42,380 lb)

Highly responsive and maneuverable

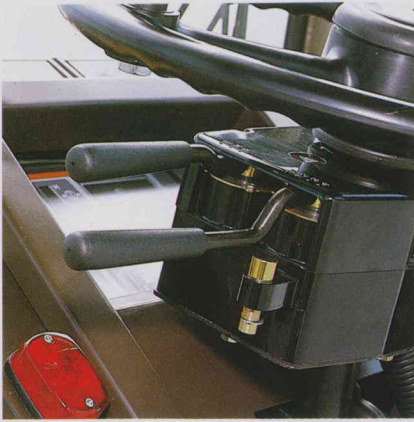

Fingertip control is realized with the electrically controlled transmission, assuring responsive, light-touch manipulation of the speed control and direction change levers provided on the side of the steering column.



Smooth, light-touch steering and work equipment control: The demand valve system guarantees light-touch steering at all times. Pilot Operated Control (POC) through a pressure proportional control valve assures light-touch work equipment control and excellent fine control.

Enhanced comfort in the cab



Spacious, comfortable cab (optional): The use of a cab with expansive tinted glass relaxes the operator and improves his visibility. Ergonomically arranged instruments, control levers and pedals boost operating efficiency. The cab is mounted on the rear frame with rubber pads to minimize noise and vibration.

An efficient operating environment

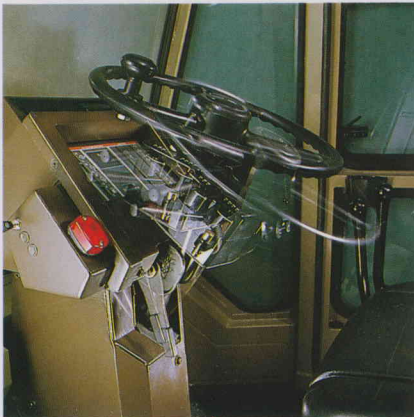

The steering wheel smoothly tilts within a 100 mm (4") range, offering ideal steering conditions for every operator.



Oil-suspension seat (optional): The seat is up/down and fore/aft adjustable with cushion hardness also varying according to the operator.



High component reliability: All components are designed and manufactured by Komatsu for maximum reliability and performance.

High performance for more production

Outstanding bucket and loader performance: Powerful breakout force, high dumping clearance, large dumping reach and smooth, fast movement enable the WA450-1 to achieve outstanding bucket and loader performance for high productivity.



High machine stability: A center-pin-supported rear axle and large oscillation angle maintain level operation on even the roughest surfaces. This, plus a long wheelbase, wide tread and large static tipping load, give the WA450-1 high stability for efficient digging/carrying operations.

The Komatsu S6D125 diesel engine delivers a lugging 237 HP (177 kW). This dynamically balanced 6-cylinder engine assures quiet, economical operation.

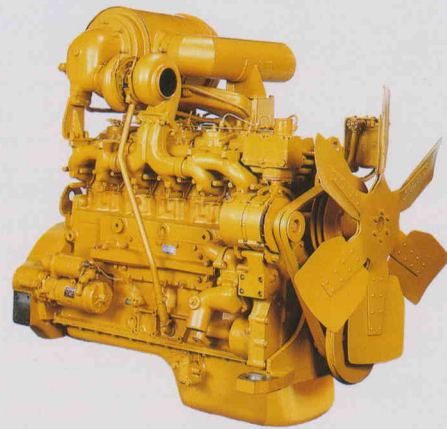

Minimum maintenance for less downtime

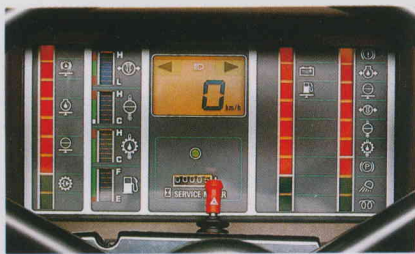

The electronic display and monitoring system

All important checkpoints are monitored and the operator is alerted through the sophisticated display panel in the event of a malfunction or emergency. The Electric System for Safety promotes foolproof operation.

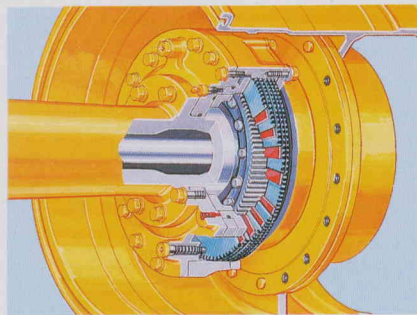

Wet, multiple-disc brakes are adjustment-free. Sure braking performance is maintained even when the machine is operated on muddy terrain. The torque proportioning differential minimizes tire slippage for extended tire life.

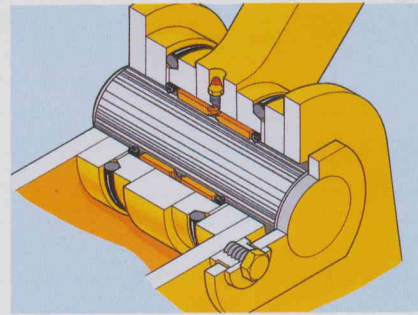

Sealed loader linkage pins need less maintenance. Bucket hinge and linkage pins are lubricated and protected by dust seals and cord rings as are all loader linkage pins. As a result, lubrication intervals are greatly extended.

SPECIFICATIONS



ENGINE

The Komatsu S6D125, is a 4-stroke, water-cooled, overhead valve, direct-injection turbocharged diesel engine. It includes six cylinders with a 125 mm (4.9") bore x 150 mm (5.9") stroke and a 11.0 ltr. (671 cu.in) piston displacement.

Flywheel horsepower:

237 HP (177 kW) at 2200 RPM (SAE J1349)

240 PS at 2200 RPM (DIN 6270 NET)

Direct-injection fuel system. All-speed mechanical governor. Gear-pump-driven force-lubrication with full-flow filters. All filters are spin-on type for easy maintenance. Dry, cyclopack air cleaner for longer element service. 24 V/7.5 kW electric starting motor. 24 V/25 A alternator. 2 x 12 V/150 Ah batteries.



TRANSMISSION

3-element, single-stage, single-phase torque converter. Full powershift, planetary-gear type transmission. A modulating function assures shockless speed and directional changes without braking. An electrically controlled transmission allows fingertip control with speed and directional change levers. A neutral safety circuit allows starting only when the directional control lever is in neutral.

Travel speed km/h (MPH)

	Forward	Reverse
1st	0-6.7 (4.2)	0-7.5 (4.7)
2nd	0-11.7 (7.3)	0-13.4 (8.3)
3rd	0-20.2 (12.6)	0-22.5 (14.0)
4th	0-34.0 (21.2)	0-37.0 (23.0)



AXLES & FINAL DRIVES

Four-wheel drive system. A full-floating front axle is fixed to the front frame. Center-pin-supported, full-floating rear axle with a large oscillation of $\pm 15^\circ$. A spiral bevel gear for reduction and a planetary gear for final reduction. Front and rear torque proportioning differentials of the straight bevel gear minimizes tire slippage, especially on soft terrain.



BRAKES

Service brakes: Air-over-hydraulic, wet, multiple-disc, brakes actuate all four-wheels. Two brake pedals provided. The right for normal braking; the left offers not only normal braking but also braking + transmission neutralizing in case the transmission cut-off switch is turned on.

Parking brake: Dry disc type, air released, spring applied on front axle pinion shaft.

Emergency brake: The parking brake is automatically actuated as an emergency brake when air pressure goes below the rated value.



TIRES

Front and rear: 23.5-25-16PR (L-3) tubeless.

Rims: 19.50 x 25 WTB.



STEERING SYSTEM

Center-pivot frame articulation. Mechanical follow-up type, full-hydraulic power assisted steering independent of engine

RPMs. A wide articulation angle of 40° on each side for a minimum turning radius of 6720 mm (22'1") at the outside corner of the bucket.



BOOM & BUCKET

Z-bar loader linkages are made of high-tensile-strength steel for maximum rigidity and offer powerful excavation. Rap-out loader linkage design enables shock dumping to fall off sticky materials. Sealed loader linkage pins with dust seals and cord rings extend greasing intervals. The bucket is also made of high-tensile-strength steel. Bucket corner teeth (optional) not only minimize bucket wear but also increase penetrating force.



BUCKET CONTROLS

Little effort is required to operate the bucket and boom control levers, assuring smooth, responsive bucket/boom action. In addition, the bucket positioner and the boom kickout device (optional) facilitate repeated digging/loading operations.

Control positions:

Boom Raise, hold, lower and float

Bucket Tilt-back, hold and dump



HYDRAULIC SYSTEM

Two gear pumps for loader control.

Capacity (discharge flow) at 2200 RPM:

Loader pump 242 ltr. (63.9 U.S. gal)/min.

Switch pump 106 ltr. (28.0 U.S. gal)/min.

Relief valve setting 210 kg/cm² (2990 PSI/20.6 MPa)

Control valves:

A 2-spool type control valve and a steering valve with a demand valve.

Hydraulic cylinders	Number of cylinders	Bore	Stroke
Boom	2	180 mm (7.09")	760 mm (29.92")
Bucket	1	200 mm (7.87")	550 mm (21.65")



SERVICE REFILL CAPACITIES

Cooling system 65 ltr. (17.2 U.S. gal)

Fuel tank 330 ltr. (87.2 U.S. gal)

Engine 26 ltr. (6.9 U.S. gal)

Brake oil 3 ltr. (0.8 U.S. gal)

Hydraulic system 140 ltr. (37.0 U.S. gal)

Axle (each front and rear) 60 ltr. (15.9 U.S. gal)

Torque converter and transmission 59 ltr. (15.6 U.S. gal)



OPERATING WEIGHT

Operating weight, including rated capacity of lubricant, coolant, full fuel tank, 23.5-25-16PR (L-3) tires, 3.5 m³ (4.6 cu.yd) capacity bucket and other standard equipment: 19225 kg (42,380 lb)



DIMENSIONS

ROPS canopy and steel cab are options.

Unit: mm (ft.in)

Dimensions vary with tires

Tire size and code	23.5-25-16PR (L-3)	26.5-25-16PR (L-3)
Tread	2200 mm (7'3")	2200 mm (7'3")
Width over tires	2835 mm (9'4")	2890 mm (9'6")
Change in vertical dimension	0	+65 mm (2.6")
Change in reach	0	-75 mm (3.0")
Change in digging depth	0°	-65 mm (2.6")
	10°	-65 mm (2.6")
Change in overall length		
Bucket on ground	0	0
Bucket at carry	0	0

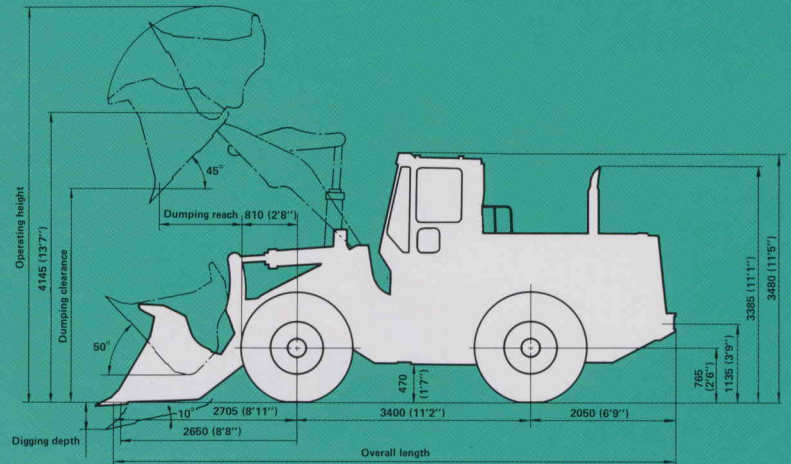

Usage		Stockpile	Excavation	Excavation
Bucket type		Straight edge	Straight edge	Spade nose
Bucket capacity	SAE rated	3.5 m ³ (4.6 cu.yd)	3.1 m ³ (4.1 cu.yd)	3.1 m ³ (4.1 cu.yd)
	Struck	3.0 m ³ (3.9 cu.yd)	2.6 m ³ (3.4 cu.yd)	2.7 m ³ (3.5 cu.yd)
Bucket width		3050 mm (10')	3050 mm (10')	3050 mm (10')
Static tipping load	Straight	15290 kg (33,710 lb)	15300 kg (33,730 lb)	15160 kg (33,420 lb)
	Full turn	13715 kg (30,240 lb)	13715 kg (30,240 lb)	13585 kg (29,950 lb)
Dumping clearance, max. height and 45° dump angle		3065 mm (10'1")	3125 mm (10'3")	3015 mm (9'11")
Reach at 2130 mm (7') cut edge clearance and 45° dump angle		1840 mm (6')	1780 mm (5'10")	1890 mm (6'2")
Reach at max. height and 45° dump angle		1245 mm (4'1")	1185 mm (3'11")	1295 mm (4'3")
Reach with arm horizontal and bucket level		2585 mm (8'6")	2500 mm (8'2")	2655 mm (8'9")
Operating height (fully raised)		5685 mm (18'8")	5560 mm (18'3")	5670 mm (18'7")
Overall length	Bucket on ground	8430 mm (27'8")	8345 mm (27'5")	8505 mm (27'11")
	Bucket at carry	8320 mm (27'4")	8265 mm (27'1")	8370 mm (27'6")
Turning radius (bucket at carry, outside corner of bucket)		6270 mm (22'1")	6715 mm (22')	6705 mm (22')
Digging depth	0°	55 mm (2.2")	55 mm (2.2")	40 mm (1.6")
	10°	395 mm (15.6")	380 mm (15.0")	400 mm (15.7")
Lifting capacity (SAE carry)		19820 kg (43,700 lb)	19820 kg (43,700 lb)	19820 kg (43,700 lb)
Breakout force (bucket cylinder)		20600 kg (45,410 lb)	22150 kg (48,830 lb)	19450 kg (42,880 lb)
Rated load		5600 kg (12,350 lb)	5600 kg (12,350 lb)	5600 kg (12,350 lb)
Operating weight		19225 kg (42,380 lb)	19290 kg (42,530 lb)	19400 kg (42,770 lb)

- All dimensions, weights and performance values based on SAE J-732C and J742b standards.
- Concerning increases or decreases according to tire size, refer to the table in DIMENSIONS.
- Static tipping load and operating weight shown include 23.5-25-16PR (L-3) tubeless tires without ballast in rear, lubricants, coolant, full fuel tank and operator. Machine stability and operating weight are affected by counterweight, tire size and other attachments. Use either tire ballast or counterweight, not both. Add the following weight changes to operating weight and static tipping load.

Weight changes

Tires and options	Change in operating weight	Change in tipping load	
		Straight	Full turn
23.5-25-16PR (L-3) tubeless tires	0/+1050 kg (2,315 lb)	0/+1680 kg (3,700 lb)	0/+1485 kg (2,990 lb)
26.5-25-16PR (L-2) tubeless tires	+200 kg (440 lb)/	+160 kg (350 lb)/	+140 kg (310 lb)/
	*+1380 kg (4,330 lb)	*+2210 kg (4,870 lb)	*+1950 kg (4,299 lb)
Canopy	+65 kg (143 lb)	+60 kg (132 lb)	+60 kg (132 lb)
ROPS canopy	+470 kg (1,036 lb)	+515 kg (1,135 lb)	+480 kg (1,058 lb)
Steel cab	+310 kg (683 lb)	+265 kg (584 lb)	+260 kg (573 lb)
Headguard	+140 kg (309 lb)	+150 kg (331 lb)	+140 kg (309 lb)
Front half fenders	+55 kg (121 lb)	+20 kg (44 lb)	+20 kg (44 lb)
Rear half fenders	+30 kg (66 lb)	+40 kg (88 lb)	+35 kg (77 lb)
Bucket teeth (unitized)	+160 kg (353 lb)	-215 kg (474 lb)	-215 kg (474 lb)
Bucket teeth (tip type)	+200 kg (441 lb)	-270 kg (595 lb)	-270 kg (595 lb)
Bolt-on edges	+240 kg (529 lb)	-325 kg (716 lb)	-325 kg (716 lb)
Counterweight (for loggers)	+860 kg (1,896 lb)	+2185 kg (4,817 lb)	+1835 kg (4,045 lb)
Additional counterweight	+325 kg (716 lb)	+830 kg (1,830 lb)	+695 kg (1,532 lb)

* Filled with CaCl₂ liquid in rear tires.

STANDARD EQUIPMENT

Engine and cooling system: Starter. Alternator. Preheater.

Electrical components: Head lights (2). Rear working lights (2). Brake lamp or tail lamp. Turn indicators (front and rear). Electric display/monitoring system.

Gauges: Fuel level. Coolant temperature. Torque converter oil temperature. Speedometer. Service meter.

Pilot lamps: Engine preheating. High-beam. Working light. Turn indicators. Parking brake applied. Transmission cut-off.

Monitor lights: Engine oil level. Brake oil level. Coolant level.

Caution lamps: Battery charging. Fuel level.

Caution lamps with alarm: Engine oil pressure. Coolant level. Coolant temperature. Torque converter oil temperature. Air pressure. Parking and neutral.

Others: Sight gauges (hydraulic reservoir level, brake oil level). Dust indicator. Emergency brake. 23.5-25-16PR (L-3) tires. Bucket positioner. General-purpose bucket, 3.5 m³ (4.6 cu.yd).

OPTIONAL EQUIPMENT

ROPS canopy
Canopy
Steel cab
Seatbelt
Air conditioner
Heater and defroster
Windshield wiper and washer
Floor mat
Sun visor
Car radio
Fire extinguisher
Suspension seat
Front fender
Rear half fender
Tire inflation kit
Vandalism protection kit
Emergency steering
Backup alarm
Front working lights
Rear-view mirrors

Work equipment:
Bucket teeth (unitized)
Bucket teeth (tip type)
Bucket corner teeth
Bolt-on cutting edges
Boom kickout
3-spool control valve
Hydraulic adaptor kit
Log clamp
Lumber fork
Dumping fork

Tires:
26.5-25-16PR (L-3) tubeless
26.5-25-16PR (L-3) tubed
23.5-25-16PR (L-3) tubed
23.5-25-20PR tubeless

This specification sheet may contain attachments and optional equipment that are not available in your area. Please consult your local Komatsu distributor for those items you may require. Materials and specifications are subject to change without notice.

 **KOMATSU**

- JAN. 1990