

# KOMATSU®

## WA380-5

NET HORSEPOWER  
140 kW 187 HP @ 2.000 rpm

OPERATING WEIGHT  
18.000 kg

BUCKET CAPACITY  
3,1 - 4,5 m<sup>3</sup>

**WA**  
**380**

WHEEL LOADER



**WA380-5**

# WALK-AROUND

The new WA380-5 wheel loader: The perfect combination of performance, comfort and economy. Never-before experienced comfort in the SpaceCab cabin, enormous tractive force and the lowest fuel consumption in it's class. And it's whisper-quiet in use, almost maintenance-free and incredibly productive with semiautomatic loading function (optional equipment). This is a wheel loader that has clearly earned its 5 stars!

### **Overwhelming Productivity**

- High-torque low-emission engine
- Extremely low fuel consumption
- Choice of operating modes for engine and transmission
- Superior dumping height and reach
- Series production ECSS load stabiliser
- Semiautomatic loading function (option)
- Completely integrated payload meter (option)

*For more detail, see page 4*

### **Excellent Driving Convenience**

- SpaceCab™ cabin
- Optimum all-around view
- Interior noise level is only 70 dB(A)\*
- Air conditioning as standard
- 2-way adjustable steering column
- Air-cushioned high comfort seat
- Operation with PPC short levers or EPC fingertip control (option)

*For more detail, see page 10*



### **Diverse and Flexible**

- Comprehensive range of attachments for a wide variety of uses

*For more detail, see page 12*

**The 5 Star Loader**

### **Ecological**

- Meets TIER II emission regulations
- Exterior noise level 104 dB(A)\*

\*measured value



**NET HORSEPOWER**  
140 kW 187 HP

**OPERATING WEIGHT**  
18.000 kg

**BUCKET CAPACITY**  
3,1 - 4,5 m<sup>3</sup>

### **Long Service Life and Reliable**

- Reliable original Komatsu components
- Robust torsionally resistant frame
- Maintenance-free fully hydraulic, wet disc service and parking brakes
- Heavy-duty axles
- Sealed DT wiring harness connector

*For more detail, see page 7*



### **Easy Maintenance**

- EMMS monitoring system
- Cab controlled reversible fan
- Swing-out oil and air to air charge cooler for easy access and cleaning
- Gull-wing doors for easy ground level access
- Extended engine oil change interval
- Centralised lubrication system as standard

*For more detail, see page 8*

# OVERWHELMING PRODUCTIVITY

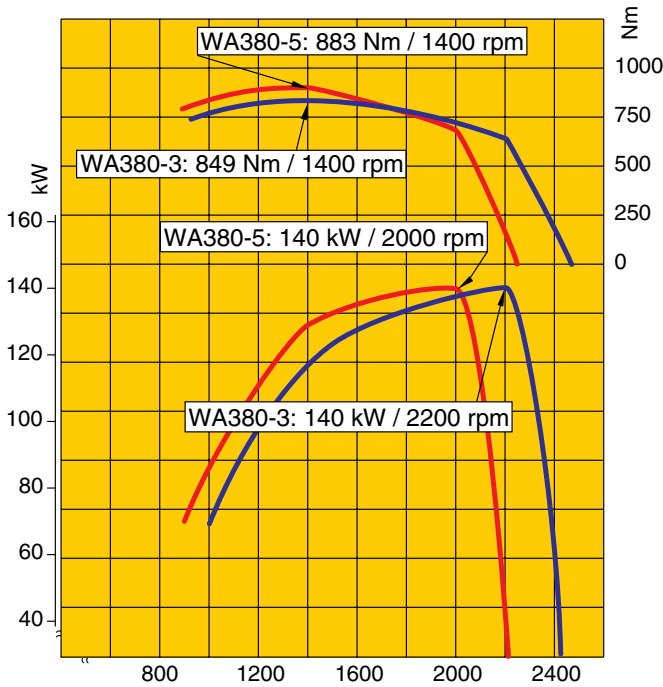

## High torque at low engine speeds

The output of the Komatsu SAA6D114E-2 low-emission engine is 140 kW (187 HP) at only 2.000 rpm. This means a constant, high power output with a 10% reduction in engine speed, compared with its predecessor. The increased engine torque and the improved torque characteristics, and also the arrangement of the newly introduced "High-Power" torque convertor contribute to a substantial improvement in traction and climbing abilities. In Load & Carry operations, faster work cycles are achieved with simultaneous savings in fuel consumption.

### When digging / scooping

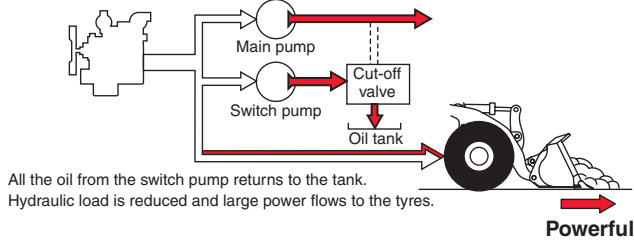

### When raising the boom

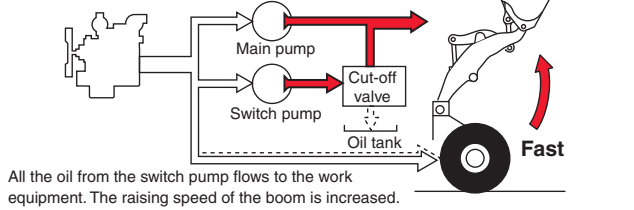

## New 2-stage hydraulic system

The working hydraulic system adapts itself excellently to your specific needs: The main and switch pump together supply great capacity for high-speed loading cycles. The main pump alone supplies a reduced oil quantity for force and the maximum tear-out strength. And there's something new: when you press the kick-down switch, the alternate pump is switched off. This means that the maximum tractive force is available while simultaneously lifting the bucket. This is important, for example, when loading feed hoppers on a steep ramp.

## Maximum dumping height and reach

The long lifting frame allows an enormous dumping height of 2.970 mm and a reach of 1.080 mm that is just as impressive (with 3,1 m<sup>3</sup> universal bucket, measured to the cutting edge).

With this working range, loading high-sided semi-trailers with a payload of 28 tonnes becomes child's play.



### Excellent stability and manoeuvrability

With a tread width of 2.160 mm and a long wheelbase of 3.300 mm, the WA380-5 offers you overwhelming stability in all working situations.

The turning circle over tyres of only 5.925 mm means you can work efficiently even in the tightest spaces.



### Mode selector switch for the engine

The operator can simply change between two modes depending upon the job. In the **Normal** mode, fuel consumption is clearly reduced by utilising a reduced-power characteristic map for the engine. This is of benefit with all general loading work. If the operator switches to **Power**, he immediately has the maximum power, for instance for hard digging or driving up steep inclines.



### Mode selector switch for the transmission

The transmission of the WA380-5 can also be adapted brilliantly to every need with the selector switch. The transmission selector switch allows the operator to select between manual transmission shifting and three automatic modes (high, medium and low). You can also find the perfect setting from saving the maximum fuel and the highest power by moving the gear-changing time depending upon speed.





## NEW OPTIONS FOR EVEN GREATER PRODUCTIVITY



### Faster Load & Carry with torque converter lockup

The operator may also utilise direct drive in third and fourth gear for optimum efficiency in Load & Carry. Clearly the speed increases, especially when driving uphill where the wheel loader travels significantly faster because of the increase in tractive force. At the same time, the converter loss is eliminated, thus clearly reducing fuel consumption.



### Semiautomatic dig

Something new in the world is Komatsu's patented function of semiautomatic bucket filling. A pre-programmed bucket filling process is carried out with the aid of the electrical pilot control. This means that it is no longer necessary to manually move the bucket lever when driving into material. This also means that operators with little experience still have productive loading cycles. And for the professionals, it's noticeably easier to operate with greater convenience.



### Payload meter

The new payload weigh scale allows perfect control of loading processes and loading power. The large and easily read display in the middle of the main monitor shows the operator a pictorial representation of each bucket load and the material quantity already loaded. Various modes allow you to alternately display the weight already loaded or how much the operator still has to load for a pre-set amount. The system also allows you to store and print out the daily output and loading output of five different materials.



# LONGEVITY AND RELIABILITY

## Quality you can rely on!

The engine, transmission, torque converter, front and rear axles are original Komatsu components. All of these component parts are subject to the highest quality requirements and strict quality assurance right down to the smallest screw. They are fully co-ordinated with one another, thus offering maximum efficiency and reliability.

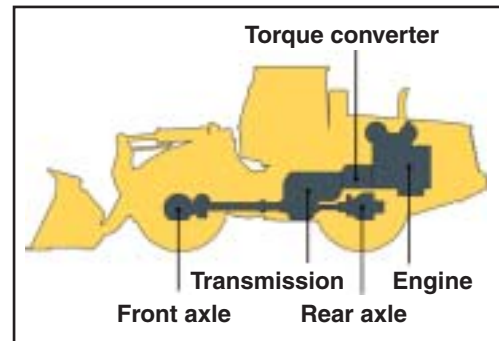

## Torsionally resistant frame

The frame design with hinge points far apart guarantees the high stability for the overall construction and reduces bearing stress in the torsional ranges. Steering angles of 40° give the WA380-5 a high degree of manoeuvrability.



## Robust HD-axes

The heavy-duty axles allow above-average service life even under the hardest working conditions. The WA380-5 can also have the optional equipment of multiple-disc limited slip differentials to further increase tractive force.



## Reliable construction equipment engines

Komatsu's reliable engine, with thick walled crank case, was developed with low noise and robustness in mind.



## Reliability right down to the details

All of the hydraulic connections are reliably protected against oil loss by Komatsu's O-ring seals. Komatsu's hydraulic cylinders are equipped with special guide rings to protect and support the cylinder rods. The electrical system is also designed for long-lasting operation (without breakdowns) with its dust- and water-proof DT plug-and-socket connections in the wiring harnesses.

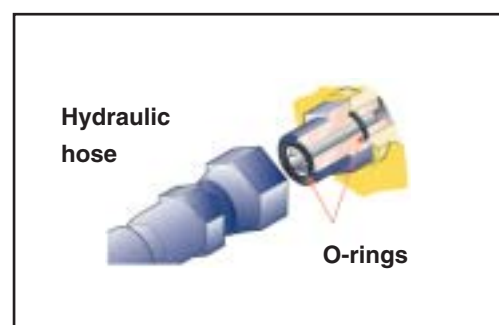

# SIMPLE AND FAST MAINTENANCE



## **Simple and convenient access to service**

The service doors are designed as gull-wing doors. They allow you convenient and safe access to the daily service points from the ground.



## **Reversible hydraulic radiator fan and swingout coolers**

The radiator fan can be switched to reverse operation from the cabin for work in dusty environments. Furthermore, oil cooler and air to air charge cooler can be swung out for easy access and fast cleaning.



## **EMMS (Equipment Management Monitoring System)**

This completely new type of monitoring system is clearly structured and easy to read because it is directly in the operators field of view. If there is a malfunction, it immediately displays the details in the chosen national language and in plain text in the display field. This system not only has an error memory and a self-diagnosis function, but also a service interval display. This significantly simplifies service work and the operator is notified on time of the regular oil and filter changes. The operator and customer-service engineer are constantly informed about the optimum machine state so that problems don't even occur in the first place.

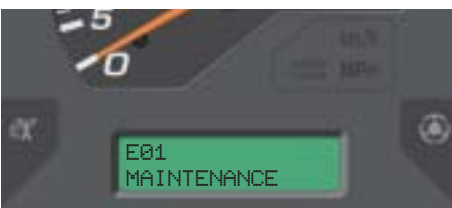



### Maintenance-free braking system

The fully hydraulic dual-circuit service brake with multi-disc brakes running in an oil bath offers you the highest degree of safety and a long service life. Something new is the fact that the braking system can be operated with even greater precision. Since it functions completely hydraulically, you no longer have the drawbacks of a compressed air braking system. The benefits of the new system are that weathering has no effect on it, it is available for work immediately after starting the engine and it's maintenance free. The multi-disc internal parking brake is also maintenance free.

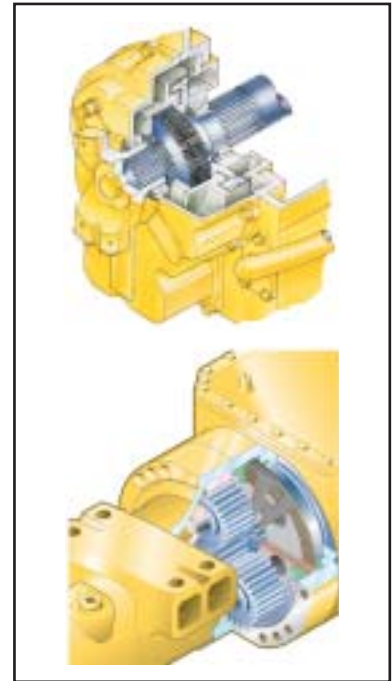

### Centralised lubrication system as standard

The centralised lubrication system reduces the daily service work to the absolute minimum. Its robust piping with protective equipment in all areas ensures constant lubrication amounts, operating reliability and electronic monitoring with a malfunction signal in the cabin. This increases the machine's service readiness and service life while lowering repair and service costs.



### Customer service and spare parts supply

When you buy a Komatsu construction machine, you buy a lot more than just the product alone. Our service support accompanies you throughout the entire life of your wheel loader. Programs for preventative maintenance are just as much a part of what we offer as the complete range of dealer service and repair programmes. And, if there is a malfunction, Komatsu's close-knit network of dealers and excellent parts service ensures you minimum downtime.



# THE SPACECAB



## **Perfect driving convenience and the best all-round visibility**

The cabin is the largest in its class and offers you unparalleled driving convenience comparable to that of a passenger car. The large frameless windscreen, ensures an optimum view of the bucket and tyres, and the slanted rear end also gives an excellent view towards the rear. The cabin is mounted on viscose shock absorbers guaranteeing an interior noise level of only 70 dB(A), one of the lowest in this class. That together with air conditioning as standard ensures the operator's well-being just as much as the air-cushioned multi-adjustable premium drivers seat with head rest, seat heater and lumbar support. The easy-to-work hydraulic operating controls on the multi-adjustable hydraulic console makes it possible to operate the wheel loader conveniently and ergonomically. The operator's well-being is ensured over long and productive hours.



# SIMPLE & CONVENIENT OPERATION

## Adjustable steering column with built-in monitor unit

The steering column with continuous tilt and height adjustment incorporates the monitoring system allowing the entire unit to be brought into the most favourable position for each individual operator. The two-spoke steering wheel makes it possible to read all of the displays and instruments without any problems.



## Automatic transmission with variable transmission cut-off

The electronically controlled automatic transmission with mode selection allows you to conveniently adjust to each job. The operator can continuously adjust the transmission cut-off activated through the left brake pedal: for instance, reacting to high cut-off pressure when excavating or low pressure for smooth braking when approaching lorries.



## New and easy-to-use joystick steering (option)

A new Joystick steering system is available as optional equipment, and ensures that steering can be wrist operated easily and conveniently in loading operations. This system allows you to change the direction of travel and gear shifting with push buttons on the joystick. And you may pre-select the steering speed in 2 stages, depending upon whether fast V-loading or precise Load & Carry is required.



## Smooth ergonomic hydraulic control

The new pilot control levers are designed as finger tip control levers for precise and fatigue-free control of the loading process. The position of the levers and the location of the entire console can be adjusted for all operators preferred height and reach. EPC equipment is also available as optional equipment for controlling the working hydraulic system. Apart from the electronic pilot control of the finger levers, EPC offers a modulating function for slowing and stopping bucket movements when lowering, that is vibration-free. Furthermore, the upper and lower boom cut out position can be pre-set with a switch that ensures major ease of operation for the operator when work is constantly changing such as in loading lorries. As a third feature, EPC equipment has a semiautomatic excavating function for simple filling buckets (also refer to page 6).

A multifunctional lever design is also available as optional equipment.





# BUCKETS AND ATTACHMENTS



## Universal bucket

This type of bucket is impressive because of its excellent penetration and loosening properties and its good material holding properties.

This universal bucket can be equipped with flush mount adapters and interchangeable teeth.



## Earthmoving bucket

The earthmoving bucket with a one-piece bucket bottom is suited both for earthworks and loading cohesive material. The slanted sides give powerful penetration. It is equipped either with flush mount adapters and interchangeable teeth or also with a rear removable edge.



## Rock bucket

V-shaped buckets offer excellent penetration properties for medium heavy-duty rock jobs.

Robust hardox design wear plates ensure a long service life. We have a selection of optional equipment with the high wear-resistant K VX™ cutting tools for extremely abrasive jobs.



## Maximum dumping height with High-Lift

The dumping height and reach can be increased for special jobs with the optional high-lift lifting frame. You may increase dumping height by approximately 53 cm and the reach is increased by approximately 16 cm.



## Hydraulic quick coupler

The WA380-5 can change attachments in a matter of seconds with the HD designed hydraulic quick coupler, available as optional equipment.



## A comprehensive range of attachments

The timber grab: With its sturdy structure and its great hydraulic power and a special tilting cylinder, the WA380-5 is also perfectly suited to work in the timber industry. The robust design of the lifting frame and axles ensure maximum durability.

# SPECIFICATIONS



## ENGINE

Type ..... Komatsu SAA6D114E-2  
water-cooled, 4-stroke, turbocharger

Rated capacity ..... 140 kW/187 HP (SAE J1349)  
at engine speed ..... 2.000 rpm

Torque/engine speed ..... max. 883 Nm/1.400 rpm

No. of cylinders ..... 6

Bore x stroke ..... 114 x 135 mm

Displacement ..... 8,27 l

Injection system ..... Direct injection

Lubricating system ..... Gear pump, pressure feed lubrication filter

Filter ..... Main-flow filter

Electrical system ..... 24 V

Battery ..... 143 Ah

Alternator ..... 60 A

Air-filter type ..... Dry-air filter with automatic dust emission  
and preliminary purification including a dust display



## TRANSMISSION

Torque converter ..... One-stage, one-phase, 3-element

Transmission ..... Automatic powershift transmission

Speeds in km/h

Gear	1.	2.	3.	4.
with 23.5 R25 tyres / with torque converter lockup:				
forwards	6,8	12,3	22,6	38,3
backwards	7,3	12,8	23,9	39,4
with 23.5 R25 tyres / without torque converter lockup:				
forwards	6,8	12,3	21,4	34,0
backwards	7,2	12,8	22,6	35,0



## CHASSIS AND TYRES

System ..... 4-wheel drive

Front axle ..... HD axle, semi-floating,  
(LSD-differential optional)

Rear axle ..... HD axle, semi-floating,  
26° swing angle (LSD-differential optional)

Countershaft ..... Spiral bevel gear

Differential ..... Straight bevel gear pair

Final drive ..... Planetary gear in an oil bath

Tyres ..... 23.5 R25 (standard)



## SERVICE REFILL CAPACITIES

Cooling system ..... 36 l

Fuel tank ..... 300 l

Motor oil ..... 32 l

Hydraulic system ..... 129 l

Axle (both front and rear axle) ..... 38 l

Torque converter and transmission ..... 54 l



## BRAKES

Operating brakes ..... Completely hydraulic dual-circuit system,  
running in oil bath  
multi-disc brakes  
on all wheels,  
service-free

Parking brake ..... Operated electrohydraulically,  
running in oil bath  
multi-disc brake,  
service-free

Emergency brake ..... Uses the parking brake



## HYDRAULIC SYSTEM

Hydraulic pump ..... Gear pump

Working pressure ..... 210 bar

Circulating capacity of the hydraulic pump ..... 212 + 94 l/min

No. of hydraulic/bucket cylinders ..... 2/1

Type ..... Double-action

Bore diameter x stroke

Hydraulic cylinder ..... 160 x 713 mm

Bucket cylinder ..... 180 x 535 mm

Hydraulic control lever ..... Pre-controlled, 2-levers

Hydraulic cycle with rated load bucket filling

Stroke time ..... 5,7 s

Lowering time (empty) ..... 3,3 s

Dumping time ..... 1,4 s



## STEERING SYSTEM

System ..... Articulated frame steering

Type ..... Completely hydraulic power steering

Steering angle to either side ..... 40°

Steering pump ..... Gear pump

Working pressure ..... 210 bar

Pumping capacity ..... 94 l/min

No. of steering cylinders ..... 2

Type ..... Double-action

Bore diameter x stroke ..... 90 x 442 mm

Smallest turn (outer edge of the tyre 23.5 R25) ..... 5.925 mm



## CABIN

Two-door cabin in conformity with ISO 3471 with ROPS (roll over protective structure) in conformity with SAE J1040c and FOPS (falling object protective structure) in conformity with ISO 3449. The air-conditioned pressurised cabin is mounted upon hydrobearings and is noise dampened.

The noise level in the cabin is in accordance with the dynamic measurement in conformity with ISO 6396:  
with blower: 71 dB(A)  
without blower: 70 dB(A)

# DIMENSIONS AND PERFORMANCE FIGURES

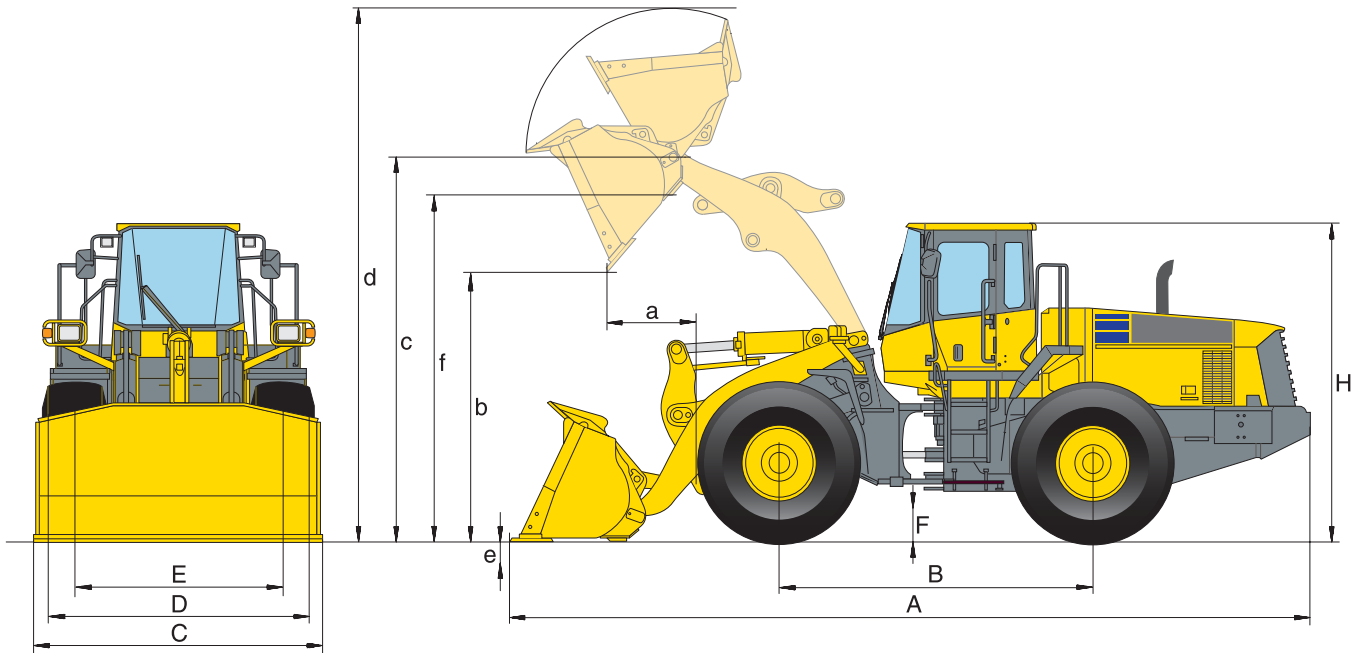

**Measurements and working specifications**

Bucket type		Universal		Earthmoving		Stockpile		Heavy Duty	
		w/o teeth	with BOC	w/o teeth	with BOC	w/o teeth	with BOC	w/o teeth	with BOC
<b>Bucket capacity (heaped, ISO 7546)</b>	<b>m<sup>3</sup></b>	<b>3,1</b>	<b>3,3</b>	<b>3,1</b>	<b>3,3</b>	<b>3,5</b>	<b>3,6</b>	<b>3,0</b>	<b>3,2</b>
Sales Code	3919-	C01	C03	C41	C43	C35	C38	C28	C30
Material density	t/m <sup>3</sup>	1,8	1,7	1,8	1,7	1,6	1,55	1,85	1,7
Bucket weight without teeth	kg	1.380	1.600	1.510	1.730	1.660	1.880	1.685	1.905
Static tipping load, straight	kg	15.310	15.090	15.180	14.960	15.030	14.810	15.005	14.785
Static tipping load, 40° articulated	kg	13.605	13.385	13.475	13.255	13.325	13.105	13.300	13.080
Break-out force hydraulic	kN	164	155	164	155	158	150	175	165
Lifting capability hydr. at ground level	kN	182	177	182	177	179	174	187	182
Operating weight (without add. counterw.)	kg	17.765	17.985	17.895	18.115	18.045	18.265	18.070	18.290
Turning radius at corner of tyres	mm	5.925	5.925	5.925	5.925	5.925	5.925	5.925	5.925
Turning radius at bucket edge	mm	6.580	6.605	6.580	6.605	6.605	6.625	6.550	6.570
a Reach at 45°	mm	1.080	1.110	1.080	1.110	1.120	1.150	1.020	1.050
b Dump height at 45°	mm	2.970	2.895	2.970	2.895	2.935	2.855	3.020	2.945
c Hinge pin height	mm	4.076	4.076	4.076	4.076	4.076	4.076	4.076	4.076
d Height top edge of bucket	mm	5.450	5.450	5.450	5.450	5.450	5.450	5.450	5.450
e Digging depth	mm	90	120	90	120	90	120	90	120
f Max. loading height at 45°	mm	3.795	3.795	3.795	3.795	3.795	3.795	3.795	3.795
A Overall length, bucket grounded	mm	8.120	8.195	8.120	8.195	8.175	8.250	8.040	8.115
B Wheelbase	mm	3.300	3.300	3.300	3.300	3.300	3.300	3.300	3.300
C Bucket width	mm	2.926	2.926	2.926	2.926	2.926	2.926	2.916	2.916
D Width over tyres	mm	2.695	2.695	2.695	2.695	2.695	2.695	2.695	2.695
E Track width	mm	2.160	2.160	2.160	2.160	2.160	2.160	2.160	2.160
F Ground clearance	mm	449	449	449	449	449	449	449	449
H Overall height	mm	3.374	3.374	3.374	3.374	3.374	3.374	3.374	3.374

All measurements with tyres 23.5 R25 L3. Details of dumping heights and reach to cutting edge or bolt-on cutting edge. Details given are for buckets without teeth; if equipped with teeth: dump height -155 mm, dump reach +155 mm, overall length +220 mm.

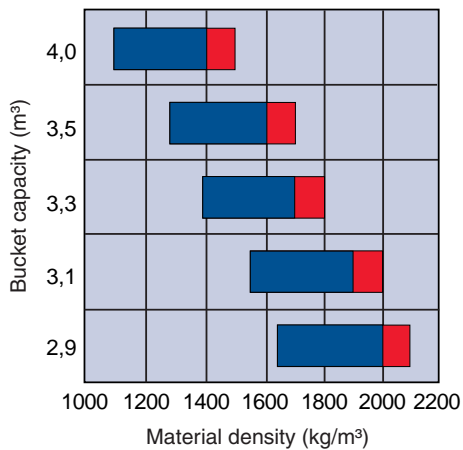
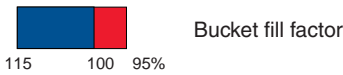

Change in data caused by:			
		Add. counter-weight	Equipment with teeth
Weight	kg	+ 325	+ 100
Stat. tipping load, straight	kg	+ 885	- 100
Stat. tipping load, 40° angle	kg	+ 750	- 100
Overall length (A)	mm	+ 145	-
Width over tyre	mm	-	-



Light materials bucket  
e.g. for industrial use such as loading lightweight recycling materials or wood chips or shavings

Stock pile bucket  
Loading loosened or broken material

Universal/Earth-moving bucket  
Ideal for road-building or earthworks, or for load & carry uses

Heavy-Duty bucket  
Loading and loosening of particularly abrasive materials

Rock bucket  
for using directly at the rock-face

Typical material density – loose (in kg/m³)	
Basalt .....	1.960
Bauxite, Kaolin .....	1.420
Earth, dry, ex store .....	1.510
Earth, wet, excavated .....	1.600
Gypsum, broken .....	1.810
Gypsum, crushed .....	1.600
Granite, broken .....	1.660
Limestone, broken .....	1.540
Limestone, crushed .....	1.540
Gravel, unscreened .....	1.930
Gravel, dry .....	1.510
Gravel, dry, 6-50 mm .....	1.690
Gravel, wet, 6-50 mm .....	2.020
Sand, dry, loose .....	1.420
Sand, damp .....	1.690
Sand, wet .....	1.840
Sand and clay, loose .....	1.600
Sand and gravel, dry .....	1.720
Sandstone .....	1.510
Slate .....	1.250
Slag, broken .....	1.750
Stone, crushed .....	1.600
Clay, natural .....	1.660
Clay, dry .....	1.480
Clay, wet .....	1.660
Clay and gravel, dry .....	1.420
Clay and gravel, wet .....	1.540

# WHEEL LOADER

## STANDARD EQUIPMENT

- |  |  |   |  |
|--|--|---|--|
| <ul style="list-style-type: none"> <li>• Universal bucket 3,1 m<sup>3</sup> (SAE, heaped)</li> <li>• Automatic return-to-dig</li> <li>• Automatic boom kick-out</li> <li>• Counterweight</li> <li>• Hydrostat-driven radiator fan with reversing function</li> <li>• Swing-out oil and air to air charge cooler</li> <li>• 2-spool main control valve</li> <li>• Central automatic lubrication</li> <li>• Electronically controlled, load stabilizer (ECSS) 2nd generation</li> <li>• Fully hydraulic brake system</li> <li>• Corrosion resistor</li> <li>• Power train guard</li> <li>• Tyres 23.5 R25 L-3</li> </ul> | <ul style="list-style-type: none"> <li>• Heavy-duty axles</li> <li>• Electronically controlled ECMV automatic transmission with mode selector and variable transmission cut-off</li> <li>• Alternator 60 A</li> <li>• Starter motor 11 kW/24 V</li> <li>• Batteries 143 Ah/2×12 V</li> <li>• Spacious double door driver's cab to DIN/ISO</li> <li>• ROPS/FOPS frame to SAE</li> <li>• All-round tinted glazing</li> <li>• Front laminated glass</li> <li>• Electronically controlled air conditioning</li> <li>• Heated rear window</li> <li>• Rear window wiper</li> <li>• Air-suspended, heated seat</li> </ul> | <ul style="list-style-type: none"> <li>• Sun visor</li> <li>• Seat belt (EU standard)</li> <li>• PPC fingertip control, two levers</li> <li>• EMMS (Equipment Management Monitoring System) with self-diagnostic function and maintenance display</li> <li>• Vertically- and horizontally-adjustable steering column with integrated monitor</li> <li>• Stereo-cassette radio</li> <li>• 2 halogen main headlights</li> <li>• 2 spotlights at front and rear</li> <li>• Reversing light</li> <li>• Horn</li> <li>• Handrails on left/right</li> </ul> | <ul style="list-style-type: none"> <li>• Emergency steering system</li> <li>• Vandalism protection</li> <li>• Tool-set</li> </ul> <p>The WA380-5 is equipped in accordance with the safety regulations of the machinery guidelines 89/392 EWG ff and EN474, and corresponds in its exhaust gas emission values with the regulations of the EC 2000/14, VIII and EC 97/68 Stage II regulations.</p> |
|--|--|---|--|

## OPTIONAL EQUIPMENT

- |   |   |   |   |
|---|---|---|---|
| <ul style="list-style-type: none"> <li>• High-lift equipment including high-lift counterweight 430 kg</li> <li>• 3-spool main control valve</li> <li>• Add. counterweight 325 kg</li> <li>• Limited-slip differential (LSD) front and rear</li> <li>• Torque converter lock-up</li> <li>• Tyres 650/65 R25</li> <li>• Tyre guard chains</li> <li>• Universal bucket 3,3 m<sup>3</sup></li> <li>• Earthmoving bucket 3,1 m<sup>3</sup></li> <li>• Earthmoving bucket 3,3 m<sup>3</sup></li> <li>• Stock pile bucket 3,5 m<sup>3</sup></li> <li>• Stock pile bucket 3,6 m<sup>3</sup></li> <li>• Heavy-duty bucket 3,0 m<sup>3</sup></li> <li>• Heavy-duty bucket 3,2 m<sup>3</sup></li> <li>• Light materials bucket 4,5 m<sup>3</sup></li> <li>• Special buckets</li> </ul> | <ul style="list-style-type: none"> <li>• Various tooth systems, BOC, segments, (Komatsu/KVX™) and other optional bucket accessories are available on request</li> <li>• Quick coupler</li> <li>• Log grapples</li> <li>• Batteries 180 Ah/2×12 V</li> <li>• Joystick steering with integrated F/R transmission function, 2-stage</li> <li>• PPC control, 1-lever (Multi-function lever)</li> <li>• Electronic 2-lever control (EPC) including:             <ul style="list-style-type: none"> <li>- Bucket stop modulation</li> <li>- Boom stop pre-setting</li> <li>- Semi-automatic dig function</li> </ul> </li> </ul> | <ul style="list-style-type: none"> <li>• Payload meter</li> <li>• Back-up alarm</li> <li>• Beacon light</li> <li>• Additional lights front and rear</li> <li>• Front screen protective grid</li> <li>• Cab air safety system</li> <li>• Exhaust gas particles filter</li> <li>• Turbo II pre-filter</li> <li>• Electronic anti-theft lock</li> <li>• 20 km/h version</li> <li>• Full rear fenders</li> <li>• Battery main switch</li> <li>• Fire extinguisher</li> <li>• Biodegradable oil for hydraulic system</li> <li>• Special paintwork</li> <li>• Wastehandler specification</li> <li>• Steelhandler specification</li> </ul> | <ul style="list-style-type: none"> <li>• Tunnel specification</li> <li>• Anti-Corrosion specification</li> <li>• General operating certification, in accordance with German Road Traffic Regulations.</li> </ul> <p>Further equipment on request.</p> |
|---|---|---|---|



**Komatsu Europe International NV**  
 Mechelsesteenweg 586  
 B-1800 VILVOORDE (BELGIUM)  
 Tel. +32-2-255 24 11  
 Fax +32-2-252 19 81  
 www.komatsueurope.com

VESS274602 05/2004

Materials and specifications are subject to change without notice.  
**KOMATSU** is a trademark of Komatsu Ltd. Japan.