

VITASEM

Mechanical seed drills





The best drill – the best harvest

PÖTTINGER seed drills meet the highest demands in functionality, reliability and performance. Unique metering systems, uniform seed placement and convenient operation are among their trademarks.

VITASEM / VITASEM CLASSIC

Mechanical linkage-mounted

VITASEM A / VITASEM A CLASSIC

Mechanical implement-mounted

VITASEM ADD

Mechanical implement-mounted seed drills with DUAL DISC coulters

Contents

	Page
Linkage-mounted seed drills	5
Implement-mounted seed drills	7 - 9
Metering system	10 - 15
Coulter systems	16 - 21
Features	22 - 27
Technical data / Equipment	28 - 31

All information on technical data, dimensions, weights, output, etc. is approximate and is not binding.



VITASEM VITASEM CLASSIC

Linkage-mounted seed drills



You can use VITASEM linkage-mounted seed drills on their own or in a combination with soil preparation implements.

VITASEM linkage-mounted

The large ground wheels drive the metering shaft and reduce the pressure the machine exerts on the soil. Wheel scrapers are standard equipment.

- The three-point linkage mounting with rugged mounting lugs and two top linkage positions enables rapid attachment to the tractor.
- The headstock is bolted to the seed hopper for added strength.

Additional equipment options

- Proven spring-loaded track eradicators.
- Compensator for lower linkages when using the seed drill on its own.
- Track eradicator for seed drill wheels: angle and penetration of the tine can be adjusted. **(1)**
- The tine can be folded away for transport.

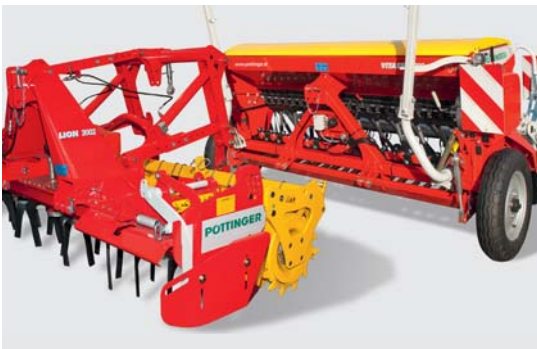

VITASEM CLASSIC

- The seed hopper height is 2.36" / 60 mm lower on VITASEM CLASSIC seed drills.
- Featuring a smaller seed hopper and semi automatic track markers – this is the lightweight version for smaller tractors.



PÖTTINGER

LION

PÖTTINGER

VITASEM A VITASEM A CLASSIC VITASEM ADD

Mechanical implement-mounted



In the field the weight of the seed drill acts directly on the rear roller. The power harrow retains its freedom of movement and can ride over stones.

Mounted on power harrows or compact combinations, the weight of the seed drill is placed as far forward as possible. The additional weight of the seed drill on the rear roller provides even better consolidation of the seedbed.

The distance between the coulters and the power harrow rear roller is minimised to form a compact unit.



VITASEM A / VITASEM A CLASSIC

- Suffolk coulters or single-disc coulters
- Coulter pressure up to 55 lbs / 25 kg.
- Depth guidance wheels optional on single-disc coulters.

VITASEM A CLASSIC models have a smaller seed hopper. They are consequently lighter and designed for operation with smaller 4-cylinder tractors. Very good visibility to the rear is possible thanks to the lower seed hopper.



VITASEM ADD

The large DUAL DISC coulters allow high working speeds when mulch drilling and operating in heavy, hard soils.

- Coulter disc diameter 13.78" / 350 mm.
- Coulter pressure up to 110 lbs / 50 kg.



Quick and easy configuration

VITASEM A implement-mounted seed drills are quickly and easily fitted to and removed from the soil preparation implement.

Easy to fit:

- Reverse under the seed drill and lift the power harrow.
- Fit locking bars to secure seed drill. **(1)**
- Remove retention pins on rear roller to create parallel linkage between packer and drill
- Fit top link to seed drill.



Parallel linkage

The implement-mounted drill is fixed to the rear roller and guided via the top link that forms a parallel linkage. **(2)**

- Packer and seed drill form a single unit.
- This enables the working depth of the power harrow to be changed by adjusting the roller without having to correct the seed drill top link.



Compact unit with centre of gravity close to tractor

A hydraulic cylinder is also available to pivot the seed drill up over the power harrow. (3)

- The best position of centre of gravity in relation to tractor.
- The high ground clearance of the drill coulters means that the power harrow can be used on its own – For example: levelling of plough furrows. (4)



Tillage Consolidation Placing and covering Levelling

Shallow working
Deep working

Seed hopper



Practical seed hopper

The front and rear wall of the VITASEM seed hopper is so steep that all the seed flows to the metering system without the need for an agitator. The headstock is integrated into the seed hopper centre wall and bulkhead plate for highest possible strength. A partition plate inside the hopper prevents the seed from wandering to one side when working across slopes.

A seed level indicator is fitted as standard.

Rugged lid with rubber seal and gas strut as standard

Two angles of opening are possible with a limit stop (85° or 103° for Big-Bags).

The design of the seed hopper lid is unique in the farming business and has been adopted from the automotive industry. Instead of being welded, the lid plate is bonded to its frame so that no weld seams are visible.

Rotating or oscillating agitator

- Available as options for seed material that is liable to bridge or does not flow well, such as grass seed.
- Can be disengaged manually easily and quickly.



Seed flow

The seed is drawn straight from underneath the feed funnel. This system ensures uniform seed flow, even when working up, down and across slopes.

Empties completely – no cleaning required

Wide, funnel-shaped outlets above each metering wheel ensure precision feed right down to the last grain, guaranteeing minimum residues and low minimum filling quantities.

The wide opening angle of the bottom flap allows for simple emptying and ensures that the metering area is completely emptied.

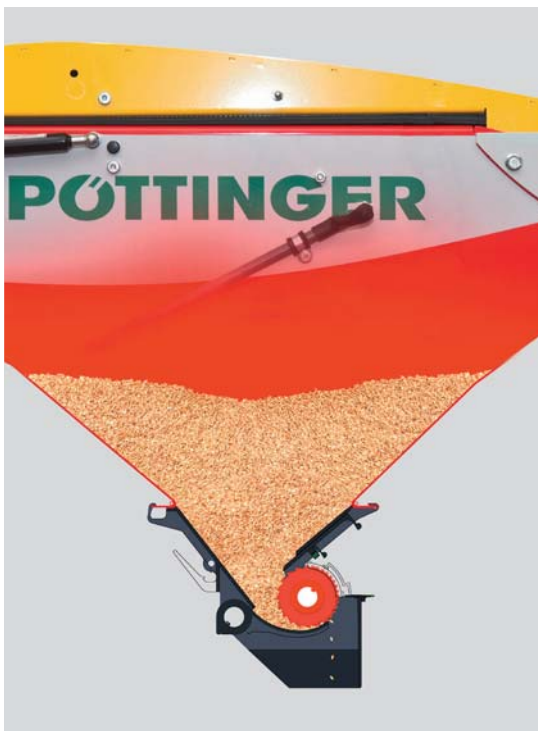

Wide loading platform

Operator access is on the left with a folding step and handrail along seed hopper. Optional right-hand bridging step available for VITASEM A. The secure handrail is mounted directly onto the seed hopper (not to the lid) for enhanced safety.

Easy to fill thanks to plenty of space for seed sacks, the handrail on the seed hopper and the large hopper opening.



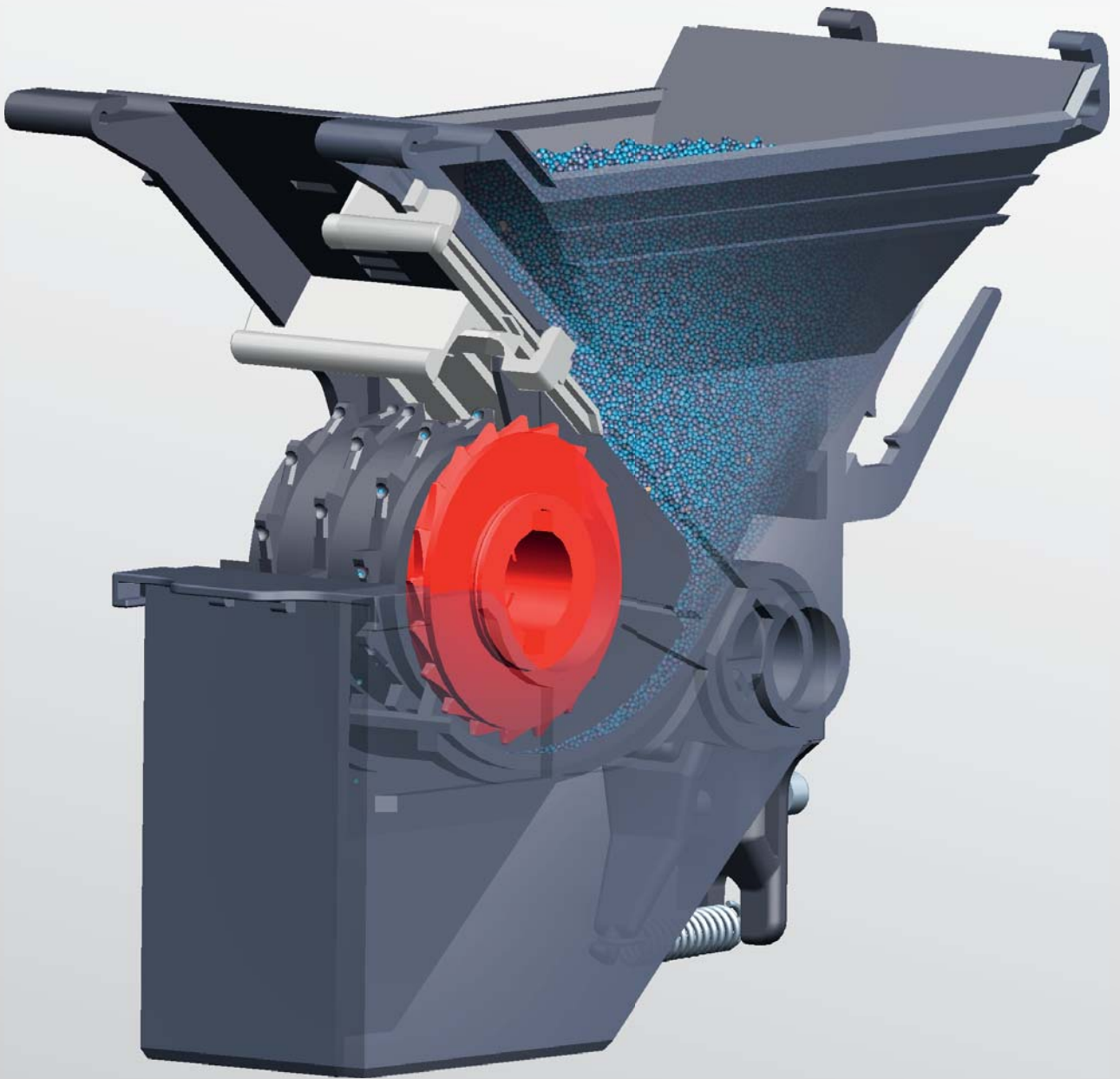

Multi sowing system



Perfection, seed by seed

Their unique seed metering system is the trademark of VITASEM seed drills.

Two completely independent metering units are combined in the one seed housing. The metering wheels are located on the same metering shaft. The advantage is that the small seed and normal metering wheels no longer need to be individually locked.

Central adjustment of seed flaps. The spring-loaded, individually adjustable flaps can easily ride over foreign objects.

The partition integrated into the seed flap prevents overflowing. The raised partition prevents grain overflow when changing from fine to normal metering, guaranteeing precision seed flow.

- The metering wheels are suitable for all kinds of standard seed types.
- The multi-sow system handles any seed with perfect metering accuracy – from 0.62 to 357 lbs per acre / 0.7 to 400 kg per hectare.
- Two individual metering wheels in each housing mean you can switch between normal seed and small seed metering within minutes.
- The benefit of this innovative solution lies in the considerable improvement to seed output accuracy with small seeds and the ease in changing between seed sizes.

The main priorities of seed drill technology – reduction in wastage and optimised plant distribution density – have been well catered for.



3 in 1 multi-sow system

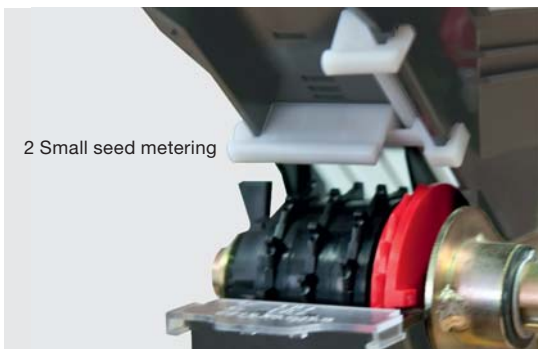

- 1 morning cereals
- 2 midday oil seed rape
- 3 evening clover, etc.

Normal metering

Standard seed, small seed

A separate inlet slide for the small seed and normal seed range make it easy to switch between small seed and normal seed metering by pushing in or pulling out the slides. The system guarantees you can switch the metering in seconds.

The optimised shape of the metering peg ensures the highest level of seed care.

Drilling oil seed rape with low numbers of seed per square meter for optimum plant distribution density is ensured by the unique small seed metering wheel with its sawtooth shaped profile.

Reverse metering

Precision sowing principle for poppy seed and clover, etc.

Unique amongst mechanical seed drills.

To plant small seeds, the direction of rotation of the metering shaft is amongst by simply switching the gears in the side drive unit. Small hollows on the rear of the sowing wheel pegs take only one grain and drop it overhead into the seed funnel.

Ideal for extremely low seed density below 0.89 lbs/acre / 1 kg/ha.



VITASEM / VITASEM A

Suffolk coulters / Single-disc coulters



Best seed placement guaranteed

Yield at harvest is influenced by precision seed placement. Regardless of whether you have light, heavy, dry or moist soil – optimum placement of the seed is critical for a satisfactory harvest.

Central coulters pressure adjustment with indicator scale (1)

Equal coulters pressure system (2)

for the same pressure on front and rear coulters.

Perfect seed slot – precise depth control (3)

Consistent row spacing

Coulters arms are secured using a large clamp mounting on the coulters rail. Wide coulters arm mountings are fitted with replaceable bushes and the ability to ride over foreign bodies with up to 7.09" / 180 mm movement upwards.

Inter coulters rail spacing (offset) of 11.81" / 300 mm provides plenty of clearance for blockage-free sowing. Seed depth is controlled via the coulters pressure even without press wheels.

The PÖTTINGER disc coulters system for best seed germination

The concave disc coulters are suitable for mulch drilling and when there is a lot of organic matter. PÖTTINGERS diagonally tracking disc coulters open up the soil. The cast shoe, similar to a Suffolk coulters, removes wilted straw and crop residues from the seed placement area and forms a neat seed slot. Uniform seed germination is guaranteed as a result.

VITASEM / VITASEM A

Advanced coulters system



Optimised coulters geometry

Different shapes of coulters with an inter coulters rail spacing (coulters offset) of 11.81" / 300 mm provide sufficient clearance even when operating in harvest trash.

Disc coulters

Concave 12.60" / 320 mm diameter single disc coulters are equipped with special dust tight seals.

The rotating scrapers are adjustable and located to the rear so as to not reduce side clearance. Easily handles large clods.

- The disc coulters are fitted with a long life hard wearing cast coulters point.

Suffolk coulters

The Suffolk coulters are suitable for soil conditions where there are low amounts of organic matter.

A protective flap closes each coulters automatically if the machine moves backwards.

The spring-mounted coulters can fold back for reliable protection.

- Wear-resistant cast coulters points.



Depth guidance press wheels

Depth guidance press wheels 9.84 x 1.57" / 250 x 40 mm available as option to limit depth and provide consolidation Straightforward pin-in-hole depth adjustment. Can be fitted and removed by hand – no tools needed.

- Even placement depth even in changeable soils.
- Presses down to cover seed perfectly. Reliable germination even in dry conditions.



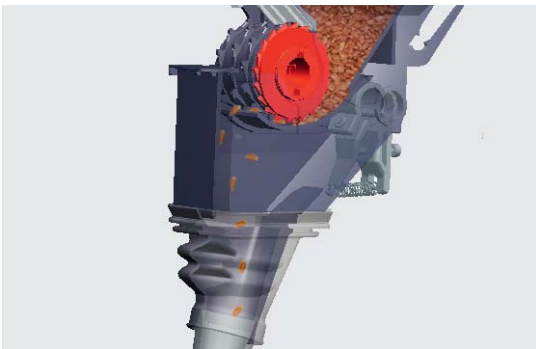

Large dimensioned seed funnel

- The large dimensioned seed funnel for transition to seed tube (especially for spelt).
- The rubber gaiters provide maximum flexibility of the seed tubes to ensure perfect transport between the metering wheel and the coulter.



The best material quality for telescopic seed tubes

The telescopic seed tubes are manufactured from stainless steel at the top and synthetic at the bottom to provide the lowest friction. This combination of materials greatly reduces the static charge in the seed grains.



VITASEM ADD

DUAL DISC Coulters



The large diameter DUAL DISC coulters cut right through surface trash to form a uniform, tidy seed slot. Harvest residues are not pressed into the ground. This system achieves a uniform, tidy seed slot. World-class technology for future-safe arable farming.

DUAL DISC

- Disc coulters diameter 13.78" / 350 mm, up to 110 lbs / 50 kg coulters pressure.
- Row spacing 4.92" / 125 mm for best plant distribution density.
- Row spacing 5.91" / 150 mm for difficult soil conditions.
- Maintenance-free coulters system.
- Aluminium coulters arms to reduce weight.
- Equal length arms – constant coulters pressure system.
- Each of the disc coulters is guided by a press wheel to ensure uniform seed placement and depth – press wheel diameter 12.99" / 330 mm.
- Inter coulters rail spacing of 11.81" / 300 mm provides a large clearance and smooth material flow even with large amounts of organic matter.

A well-formed, tidy seed slot is essential for successful drilling. The guarantee for optimum placement and uniform germination. The seed is placed at defined intervals, covered with a layer of fine soil and firmed down by press wheels.

Easy depth adjustment

The depth can be quickly adjusted using the ratchet spanner provided, on either side at the front of the seed drill.

The depth scale guarantees uniform seed placement and depth.

Perfect sowing



Rear harrow options

The 0.39" / 10 mm harrow tines feature coil springs for perfect ground tracking. Shocks are absorbed using maintenance-free rubber mountings and damage is prevented if the machine is reversed inadvertently.

- Central tine angle adjustment.
- Easy to use adjustment functions for depth and pressure.
- Outer tines can be retracted for road transport (9.84 and 13.12' / 3.0 and 4.0 m transport width).
- No additional adapters required if press wheels are fitted

Standard single-row harrow tine

- The tines are positioned between the seed lines.
- Ridging is prevented by a pair of cranked harrow tines at either end.
- These tines are positioned between the seed lines. to prevent blockages even in heavy organic material.

PERFEKT harrow tines

- Designed for an intensive levelling effect.
- Cranked tines sweep the whole surface level.
- The seed is covered effectively, even when placed at a shallow depth. The result is uniform germination of every seed.



Step-less metering gearbox runs in high viscosity oil

Consistent land wheel drive

- On VITASEM A seed drills the land wheel is positioned within the working width – no need to remove the wheel for road transport.
- The large diameter wheel has a large area of contact with the ground to minimise slippage. A hydraulic lift system is also available.
- The gears inside the infinitely adjustable metering gearbox run in high viscosity oil for smooth, uniform seed flow, even at low speed.
- Quick, accurate adjustment of the seed rate by shifting the lever on the finely-calibrated scale on the side of the machine.
- The number of revolutions for calibration are reduced by half.



Electric metering

For VITASEM A / VITASEM ADD

- Electric metering is available as an option in connection with a POWER CONTROL or CCI ISOBUS control terminal.
- The speed signal is provided by the optional DGPS sensor or by the tractor radar sensor.
- No land wheel.
- The seed flow rate can easily be adjusted from the tractor seat.
- Calibration at the press of a button.

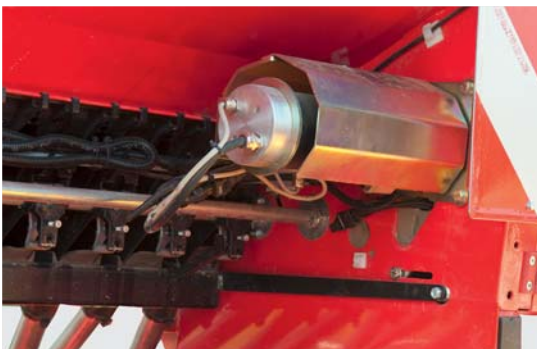

Easy to set up



It couldn't be more straightforward

All adjustments can be made from the left-hand side or rear of the machine. Everything in one place saves time. The adjustment controls are easily accessible and positioned ergonomically.

Central coulters pressure adjustment

Coulters pressure is adjusted centrally on the left hand side of the machine (against an indicator scale). Precise tension spring matching ensures the same pressure is applied to the front and rear coulters.

- A coulters pressure of up to 55 lbs / 25 kg is possible on the VITASEM **(1)** and VITASEM A **(2)**
- Hydraulic coulters pressure adjustment is also available.
- Central coulters pressure adjustment on the VITASEM ADD up to a pressure of 110 lbs / 50 kg. **(3)**

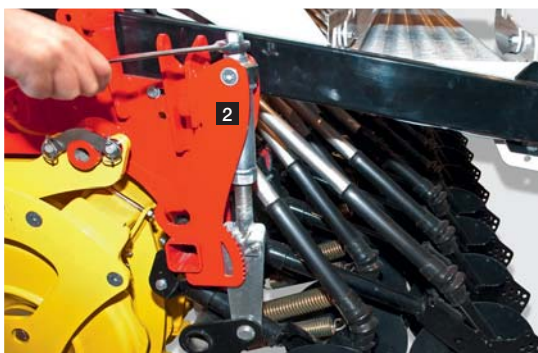



Bout markers

Scalloped bout marker discs optional (1)

- 15.75" / 400 mm diameter for a clearly visible centreline.
- Hydraulically operated with switchover valve and a mechanical interlock.
- Shear bolt overload protection.



Calibration

Whether calibrating, working in the field or emptying the seed hopper – each step has been optimised.

- Calibration system with integrated freewheel for stationary calibration. (2)
- Calibration system with output adjustment.
- Access ladder and land wheel are laid out intuitively on the left-hand side of the machine.

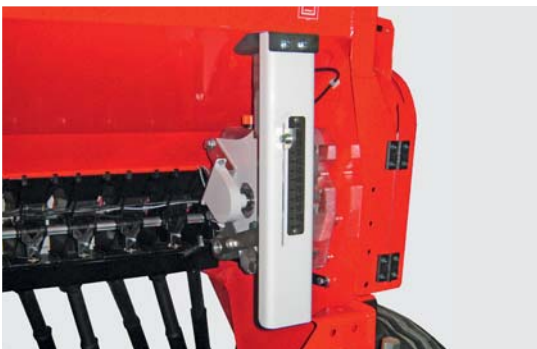

Electric seed rate adjustment

With the electric seed rate system, you can change the output from the tractor seat without stopping.

COMPASS

Convenient to use

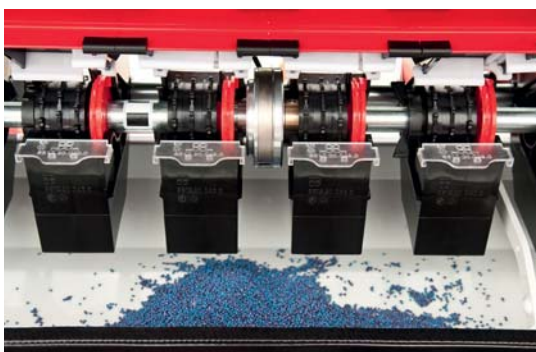

COMPASS terminal

COMPASS, the optional electronic control unit, makes it easier to operate the machine and guarantees consistent monitoring. Modern, multiple-line graphic display with a raised, back-lit keypad.

- Automatic tramline switching with tramline stop.
- Speed display.
- Job and total hectare counter.
- Available as option: additional metering shaft and level indicator plus electrical seed flow-rate adjustment.
- Optional POWER CONTROL terminal for VITASEM A and VITASEM ADD with electric metering drive.
- Optional CCI ISOBUS terminal – this terminal lets you operate all ISOBUS-compatible machines, regardless of brand. SEED COMPLETE is then also possible.

Calibration using COMPASS:

- Enter quantity and current gear setting.
- Calibrate for 1/10, 1/20, 1/40 or 1/100 ha.
- The rotations are counted and a signal sounds for the last five.
- Enter calibrated amount – new gear setting is calculated.
- 10 languages, 328' / 100 m compensation, sensor test.

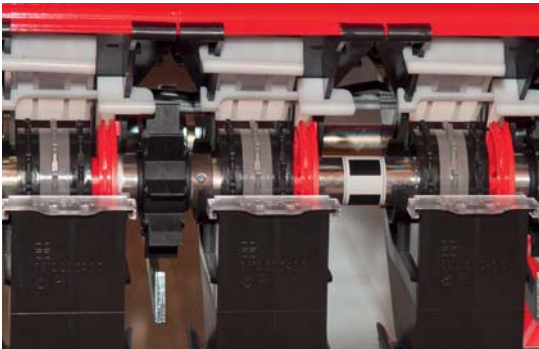

Tramline switching:

Tramlines are controlled via the COMPASS control unit.

- An electric motor shuts off the relevant metering wheels.
- Up to five metering wheels can be switched off per track.
- You only need to enter the spraying width and the tramline rhythm will be calculated automatically.
- Asymmetric tramlines and custom tramline configurations are also possible.
- Different track widths are possible on one machine. Ideal for shared machinery and contract work.



VITASEM

Switching via transmission signal or bout marker change-over valve.

VITASEM A / ADD mechanical metering drive

Switching via land wheel sensor, transmission signal or bout marker change-over valve.

VITASEM A / ADD electrical metering drive

Tractor hitch signal or sensor wheel.



Pre-emergence markers

Pre-emergence markers optional

Controlled by the tramline switching.



Technical data

VITASEM	252 CLASSIC	252	302 CLASSIC	302	402
Working width ft / m	8.20 / 2.50	8.20 / 2.50	9.84 / 3.0	9.84 / 3.0	13.12 / 4.0
Transport width ft / m	8.20 / 2.50	8.20 / 2.50	9.84 / 3.0	9.84 / 3.0	13.12 / 4.0
Rows	21	21	25	21 / 25	27 / 33
Row spacing inch / mm	4.72 / 120	4.72 / 120	4.72 / 120	5.63/4.72 / 143/120	5.63/4.72 / 143/120
Seed hopper gal / l	79 / 360	106 / 480	99 / 450	132 / 600	187 / 850
Seed hopper optional gal / l	–	–	–	220 / 1000	308 / 1400
Filling height standard ft / m	4.27 / 1.30	4.46 / 1.36	4.27 / 1.30	4.46 / 1.36	4.46 / 1.36
Filling height extended ft / m	–	–	–	5.09 / 1.55	5.09 / 1.55
Coulter disc diameter inch / mm	12.60 / 320	12.60 / 320	12.60 / 320	12.60 / 320	12.60 / 320
Inter coulter rail spacing inch / mm	11.81 / 300	11.81 / 300	11.81 / 300	11.81 / 300	11.81 / 300
Coulter pressure up to lbs / kg	55 / 25	55 / 25	55 / 25	55 / 25	55 / 25
Tyres	6.00-16	6.00-16	6.00-16	6.00-16 / 10/75-15.3	10/75-15.3
Weight with Suffolk coulters lbs / kg	1157 / 525	1201 / 545	1294 / 587	1279/1373 / 580/609	1731/1825 / 785/828
Weight with disc coulters lbs / kg	1301 / 590	1345 / 610	1462 / 663	1422/1510 / 645/685	1911/2044 / 867/927



VITASEM	252 A CLASSIC	252 A	302 A CLASSIC	302 A	402 A
Working width ft / m	8.20 / 2.50	8.20 / 2.50	9.84 / 3.0	9.84 / 3.0	13.12 / 4.0
Transport width ft / m	8.20 / 2.50	8.20 / 2.50	9.84 / 3.0	9.84 / 3.0	13.12 / 4.0
Rows	20	20	24	20 / 24	26 / 32
Row spacing inch / mm	4.92 / 125	4.92 / 125	4.92 / 125	5.91/4.92 / 150/125	5.91/4.92 / 150/125
Seed hopper gal / l	79 / 360	106 / 480	99 / 450	132 / 600	187 / 850
Seed hopper optional gal / l	–	–	–	220 / 1000	308 / 1400
Filling height standard ft / m	4.27 / 1.30	5.28 / 1.61	4.27 / 1.30	5.28 / 1.61	5.28 / 1.61
Filling height extended ft / m	–	–	–	5.91 / 1.80	5.91 / 1.80
Coulter disc diameter inch / mm	12.60 / 320	12.60 / 320	12.60 / 320	12.60 / 320	12.60 / 320
Inter coulter rail spacing inch / mm	11.81 / 300	11.81 / 300	11.81 / 300	11.81 / 300	11.81 / 300
Coulter pressure up to lbs / kg	55 / 25	55 / 25	55 / 25	55 / 25	55 / 25
Weight with Suffolk coulters lbs / kg	1102 / 500	1146 / 520	1230 / 558	1204/1268 / 546/575	1545/1638 / 701/743
Weight with disc coulters lbs / kg	1232 / 559	1276 / 579	1382 / 627	1334/1420 / 605/644	1713/1843 / 777/836

VITASEM	302 ADD	402 ADD
Working width ft / m	9.84 / 3.0	13.12 / 4.0
Transport width ft / m	9.84 / 3.0	13.12 / 4.0
Rows	20 / 24	26 / 32
Row spacing inch / mm	5.91/4.92 / 150/125	5.91/4.92 / 150/125
Seed hopper gal / l	132 / 600	187 / 850
Seed hopper optional gal / l	220 / 1000	308 / 1400
Filling height standard ft / m	5.28 / 1.61	5.28 / 1.61
Filling height extended ft / m	5.91 / 1.80	5.91 / 1.80
DUAL DISC diameter inch / mm	13.78 / 350	13.78 / 350
Inter coulter rail spacing inch / mm	11.81 / 300	11.81 / 300
Coulter pressure lbs / kg	110 / 50	110 / 50
Weight with DUAL DISC lbs / kg	1989/2163 / 902/981	2317/2551 / 1051/1157

Equipment



VITASEM

COMPASS Control terminal

POWER CONTROL terminal

CCI ISOBUS Control terminal

SEED COMPLETE

252 / 302 CLASSIC	<input type="checkbox"/>	-	-	-
252 A / 302 A CLASSIC	<input type="checkbox"/>	-	-	-
252 / 302 / 402	<input type="checkbox"/>	-	-	-
252 A / 302 A / 402 A	<input type="checkbox"/>	- / <input type="checkbox"/> / <input type="checkbox"/>	- / <input type="checkbox"/> / <input type="checkbox"/>	- / <input type="checkbox"/> / <input type="checkbox"/>
302 ADD / 402 ADD	<input type="checkbox"/>	<input type="checkbox"/>	<input type="checkbox"/>	<input type="checkbox"/>



VITASEM

Loading platform Bridge step for loading platform

Track eradicators for tractor wheels

Wheel track eradicator

Hydraulic bout marker

252 / 302 CLASSIC	<input type="checkbox"/> / -	- / <input type="checkbox"/>	<input type="checkbox"/>	<input type="checkbox"/> / <input type="checkbox"/>
252 A / 302 A CLASSIC	<input type="checkbox"/> / <input type="checkbox"/>	-	-	- / <input type="checkbox"/>
252 / 302 / 402	<input type="checkbox"/> / -	- / <input type="checkbox"/> / <input type="checkbox"/>	<input type="checkbox"/>	- / <input type="checkbox"/> / <input type="checkbox"/>
252 A / 302 A / 402 A	<input type="checkbox"/> / <input type="checkbox"/>	-	-	- / <input type="checkbox"/> / <input type="checkbox"/>
302 ADD / 402 ADD	<input type="checkbox"/> / <input type="checkbox"/>	-	-	<input type="checkbox"/>

■ = Standard, □ = Option, standard equipment varies from country to country

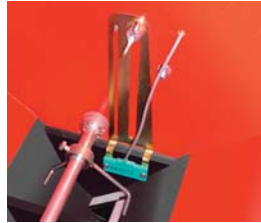

Electric metering

Tramline switching

Electronic monitoring for seed level and metering shaft

Electric seed rate adjustment

Rotating / oscillating agitator

-	<input type="checkbox"/>	<input type="checkbox"/>	-	<input type="checkbox"/>
-	<input type="checkbox"/>	<input type="checkbox"/>	-	<input type="checkbox"/>
-	<input type="checkbox"/>	<input type="checkbox"/>	<input type="checkbox"/>	<input type="checkbox"/>
-/□/□	<input type="checkbox"/>	<input type="checkbox"/>	<input type="checkbox"/>	<input type="checkbox"/>
<input type="checkbox"/>	<input type="checkbox"/>	<input type="checkbox"/>	<input type="checkbox"/>	<input type="checkbox"/>

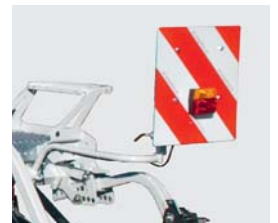

Press wheels

**Harrow tines
PERFEKT harrow tines**

Pre Emergence markers

Hydraulic raising of land drive wheel

Lighting and warning signs

<input type="checkbox"/>	<input type="checkbox"/>	<input type="checkbox"/>	-	<input type="checkbox"/>
<input type="checkbox"/>	<input type="checkbox"/>	<input type="checkbox"/>	<input type="checkbox"/>	<input type="checkbox"/>
<input type="checkbox"/>	<input type="checkbox"/>	<input type="checkbox"/>	-	<input type="checkbox"/>
<input type="checkbox"/>	<input type="checkbox"/>	<input type="checkbox"/>	<input type="checkbox"/>	<input type="checkbox"/>
■	<input type="checkbox"/>	<input type="checkbox"/>	<input type="checkbox"/>	<input type="checkbox"/>

Other optional fittings:

- Mechanical top link for VITASEM A / ADD
- Hydraulic top link for VITASEM A / ADD
- Coarse metering wheel for large seeds (beans)
- Adapter for sowing small seeds with normal metering wheel
- Cover for metering unit
- Drive for reversing direction of metering wheels
- Compensator arm for lower linkage
- Tyres 10/75-15.3 for VITASEM 302

- Hydraulic coultter pressure adjustment
- Mechanical hectare counter
- Tramline extension
- Tine protection for perfect tine harrow
- Spring balance weighing scales
- Press wheel scrapers for VITASEM ADD



Your machine goes online.

All the information on your machine
easily – anytime – anywhere

Simply scan the QR code on the data plate with your smartphone or tablet or enter your machine number at www.poettinger.at/poetpro. You will immediately receive all the information on your machine.

- Instruction manual
- Optional equipment information
- Brochures
- Photos and videos



PÖTTINGER Spare parts service

- Worldwide network of sales and service partners.
- Decades of spare and wear parts availability.
- Original parts can be ordered online around the clock.

PÖTTINGER Landtechnik GmbH

Industriegelände 1
4710 Grieskirchen
Austria
Phone +43 7248 600-0
Fax +43 7248 600-2511
info@poettinger.at
www.poettinger.at

POETTINGER US, Inc.

393 Pilot Drive
Valparaiso, IN 46383
USA
Phone +1 219 510-5534
Fax + 1 219 707-5412
sales.us@poettinger.us
www.poettinger.us

Importer for New Zealand:

Origin Agroup
PO Box 673, 57 Hautapu Road
Cambridge
New Zealand
Phone +64 7 823 7582
info@originagroup.co.nz
www.originagroup.co.nz

Alois PÖTTINGER UK Ltd.

15 St Marks Road, Corby
Northamptonshire,
NN18 8AN
United Kingdom
Phone + 44 1536 272 220
info.uk@pottingeruk.co.uk
www.pottingeruk.co.uk

POETTINGER Australia PTY LTD

15 Fordson Road
Campbellfield, VIC 3061
Australia
Phone +61 3 9359 2969
sales.au@poettinger.com.au
www.poettinger.com.au

Importer for South Africa:

VALTRAC
Cnr. Water & Buiten Street
9585 Parys
South Africa
Phone +27 56 817 7338 7308
wynn@valtrac.co.za
www.valtrac.co.za

POETTINGER Canada Inc.

650, Route 112
St-Cesaire, PQ J0L 1T0
Canada
Phone +1 450 469 5594
Fax +1 866 417 1683
sales.canada@poettinger.ca
www.poettinger.ca

POETTINGER Ireland Ltd.

Industrial Estate
Cashel Rd., Clonmel, Co. Tipperary
Ireland
Phone +353 52 6125766
info.ie@poettinger.at
www.poettinger.ie

