

TADANO CARGO CRANE

MODEL : **TM-ZE366HRS**

CRANE SPECIFICATIONS

<u>CRANE CAPACITY</u>	3,030 kg at 2.3 m (4-part lines)
<u>BOOM</u>	Six-sectioned, fully powered partly synchronized telescoping boom of pentagonal box construction Retracted length ----- 3.65 m Extended length ----- 14.6 m Extending speed ----- 10.95 m / 19 s Elevation ----- Elevated by a double-acting hydraulic cylinder Elevating speed ----- 1° to 78° / 7.5 s Boom point ----- 2 sheaves
<u>WINCH</u>	Hydraulic motor driven Spur gear speed reduction, provided with mechanical brake and cable follower Single line pull ----- 7.45 kN{760 kgf} Single line speed ----- 76 m/min (at 4th layer) Wire rope Diameter x length --- 8 mm x 85 m Breaking strength --- 43.1 kN{4.39 tf} Construction ----- 7 x 7 + 6 x WS(26) Hook block ----- 2 sheaves
<u>HOOK STOWING DEVICE</u>	Mechanically stowed beneath boom top portion

SWING

Hydraulic motor driven Worm gear speed reduction Continuous
 360° full circle swing on ball bearing slew ring
 Automatic swing lock
 Swing speed ----- 2.5 min⁻¹{rpm}

OUTRIGGERS

Manually extended sliders and hydraulically extended jacks
 Integral with crane frame Power up and down
 Extension width ---- Min. 2,000 mm
 Mid. 2,700 mm, 3,400 mm
 Full 4,200 mm

REAR OUTRIGGERS (Locally provided)

Full extension width --- Not less than 2,800 mm

HYDRAULICS

Hydraulic pump ----- Single gear pump
 Hydraulic motors ----- Axial piston type for winch
 Axial piston type for swing
 Control valves ----- Multiple control valves with integral safety
 valve
 Oil tank capacity ----- approx. 31 L

RADIO CONTROLLER

Model : RCS-F
 Control functions of boom telescoping, hoisting up and down,
 boom elevating, swing, acceleration, speed mode selection,
 working height limiting, Hook-in, Hook-out, horn and emergency
 stop
 Frequency ----- 40 frequencies in 433 MHz band
 Operating power supply
 Transmitter ----- 6V DC, Dry battery R6P(SUM-3) x 4
 Control unit ----- 24V DC, Vehicle battery
 Transmitter mass ---- Approx. 576 g (includes batteries)

SAFETY DEVICES

AML(Automatic Moment Limiter)
 Load indication
 Load moment ratio to rated load indication
 Warning alarm
 Over load limiter
 WHL(Working Height Limiter)
 Load meter
 Radius indicator
 Emergency stop switch on radio controller
 Terminal for emergency stop switch
 Over-winding alarm
 Hoisting limiter
 Jack interlock
 P.T.O indicator lamp
 Hook safety latch
 Hydraulic safety valves, check valves and holding valves
 Level gauge

CRANE MASS

Approx. 1,535 kg (includes standardized mounting parts)

NOTE : Operating speeds of the crane are guaranteed under the condition that the pump
 delivery is 60 L/min.

RATED LIFTING CAPACITIES IN KILOGRAMS

Crane Strength Rated Capacities

Load Radius	3.65 m / 5.87 m Boom		Load Radius	8.07 m Boom Extension width of outriggers Full	Load Radius	10.2 m Boom Extension width of outriggers Full	Load Radius	12.4 m Boom Extension width of outriggers Full	Load Radius	14.6 m Boom Extension width of outriggers Full
	Extension width of outriggers									
	Full	Minimum								
2.3 m and below	3,030	1,380	2.7 m and below	2,330	4.0 m and below	1,030	5.0 m and below	700	4.9 m and below	400
2.5 m	2,830	1,230	3.0 m	2,130	5.0 m	880	6.0 m	580	6.0 m	360
3.0 m	2,380	880	3.5 m	1,880	6.0 m	730	7.0 m	500	7.0 m	330
3.5 m	1,980	680	4.0 m	1,630	7.0 m	630	8.0 m	430	8.0 m	300
4.0 m	1,680	530	4.5 m	1,450	8.0 m	580	9.0 m	380	9.0 m	280
4.5 m	1,450	430	5.0 m	1,280	9.0 m	510	10.0m	330	10.0m	260
5.0 m	1,280	330	5.5 m	1,130	10.05m	480	11.0m	300	11.0m	240
5.67m	1,080	280	6.0 m	1,000			12.22m	280	12.0m	220
			6.5 m	880					13.0m	200
			7.0 m	800					14.4m	180
			7.87m	680						

- NOTES : 1. The mass of hook block (30kg), slings and all similarly used load handling devices must be added to the mass of load.
 2. The above numerical values of total rated loads are based on crane strength only. The total rated loads based on stability may lower than those in the above table depending on the loading conditions and the types of the chassis.

Table A Empty Chassis Rated Capacities

Load Radius	3.65 m / 5.87 m Boom		Load Radius	8.07 m Boom Extension width of outriggers Full	Load Radius	10.2 m Boom Extension width of outriggers Full	Load Radius	12.4 m Boom Extension width of outriggers Full	Load Radius	14.6 m Boom Extension width of outriggers Full
	Extension width of outriggers									
	Full	Minimum								
2.3 m and below	3,030	1,280	2.7 m and below	2,230	4.0 m and below	1,030	5.0 m and below	630	4.9 m and below	330
2.5 m	2,780	1,130	3.0 m	2,030	5.0 m	830	6.0 m	480	6.0 m	280
3.0 m	2,280	780	3.5 m	1,680	6.0 m	700	7.0 m	400	7.0 m	250
3.5 m	1,880	580	4.0 m	1,380	7.0 m	530	8.0 m	350	8.0 m	230
4.0 m	1,430	480	4.5 m	1,180	8.0 m	430	9.0 m	310	9.0 m	210
4.5 m	1,180	380	5.0 m	980	9.0 m	350	10.0m	280	10.0m	190
5.0 m	980	280	5.5 m	830	10.05m	300	11.0m	250	11.0m	170
5.67m	820	230	6.0 m	700			12.22m	210	12.0m	160
			6.5 m	600					13.0m	140
			7.0 m	530					14.4m	130
			7.87m	450						

Table C

Load Radius	3.65 m / 5.87 m Boom		Load Radius	8.07 m Boom Extension width of outriggers Full	Load Radius	10.2 m Boom Extension width of outriggers Full	Load Radius	12.4 m Boom Extension width of outriggers Full	Load Radius	14.6 m Boom Extension width of outriggers Full
	Extension width of outriggers									
	Full	Minimum								
2.3 m and below	3,030	1,380	2.7 m and below	2,230	4.0 m and below	1,030	5.0 m and below	630	4.9 m and below	330
2.5 m	2,780	1,230	3.0 m	2,030	5.0 m	830	6.0 m	480	6.0 m	280
3.0 m	2,280	880	3.5 m	1,680	6.0 m	730	7.0 m	400	7.0 m	250
3.5 m	1,930	680	4.0 m	1,380	7.0 m	600	8.0 m	350	8.0 m	230
4.0 m	1,630	530	4.5 m	1,180	8.0 m	480	9.0 m	310	9.0 m	210
4.5 m	1,330	430	5.0 m	1,050	9.0 m	400	10.0m	280	10.0m	190
5.0 m	1,080	330	5.5 m	880	10.05m	330	11.0m	250	11.0m	170
5.67m	880	280	6.0 m	780			12.22m	230	12.0m	160
			6.5 m	680					13.0m	140
			7.0 m	600					14.4m	130
			7.87m	500						

Table D

Load Radius	3.65 m / 5.87 m Boom		Load Radius	8.07 m Boom	Load Radius	10.2 m Boom	Load Radius	12.4 m Boom	Load Radius	14.6 m Boom
	Extension width of outriggers			Extension width of outriggers		Extension width of outriggers		Extension width of outriggers		Extension width of outriggers
	Full	Minimum		Full		Full		Full		Full
2.3 m and below	3,030	1,380	2.7 m and below	2,330	4.0 m and below	1,030	5.0 m and below	700	4.9 m and below	400
2.5 m	2,830	1,230	3.0 m	2,130	5.0 m	880	6.0 m	580	6.0 m	360
3.0 m	2,380	880	3.5 m	1,880	6.0 m	730	7.0 m	500	7.0 m	330
3.5 m	1,980	680	4.0 m	1,630	7.0 m	630	8.0 m	430	8.0 m	300
4.0 m	1,680	530	4.5 m	1,450	8.0 m	580	9.0 m	380	9.0 m	280
4.5 m	1,450	430	5.0 m	1,280	9.0 m	510	10.0m	330	10.0m	260
5.0 m	1,280	330	5.5 m	1,130	10.05m	480	11.0m	300	11.0m	240
5.67m	1,080	280	6.0 m	1,000			12.22m	280	12.0m	220
			6.5 m	880					13.0m	200
			7.0 m	800					14.4m	180
			7.87m	680						

- NOTES :
1. Empty Chassis Rated Capacities in these tables depend on condition that crane is set level on firm level ground.
 2. The mass of hook block (30 kg), slings and all similarly used load handling devices must be added to the mass of load.
 3. For boom lengths not shown, use the rated lifting capacity of next longer boom.
 4. When outriggers are extended to middle extension width, use the rated lifting capacities for outriggers are extended to minimum extension width .
 5. For boom lengths longer than 5.87m, extend outriggers to full extension width.
 6. When the boom length is 10.2 m, a half of the first ◻ mark on lateral face of the 4th boom section is exposed out of the 3rd boom section.
 7. When the boom length is 12.4 m, a half of the second ◻ mark on lateral face of the 4th boom section is exposed out of the 3rd boom section.
 8. Empty Chassis Rated Capacities table A ,C and D depend on the types of chassis.
 9. Empty Chassis Rated Capacities are shown for over-side areas and over-rear area. These capacities for over-front area may lowered depending on the types of chassis.

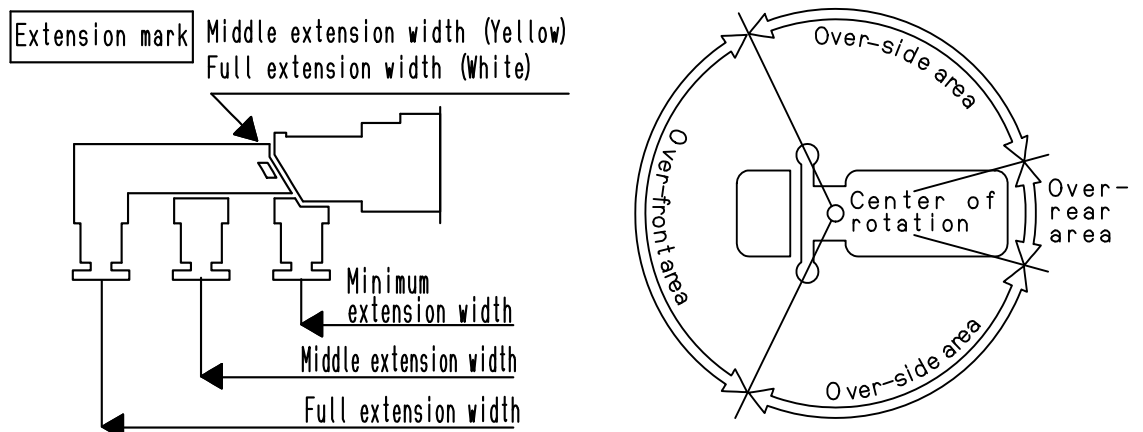

WORKING RANGE

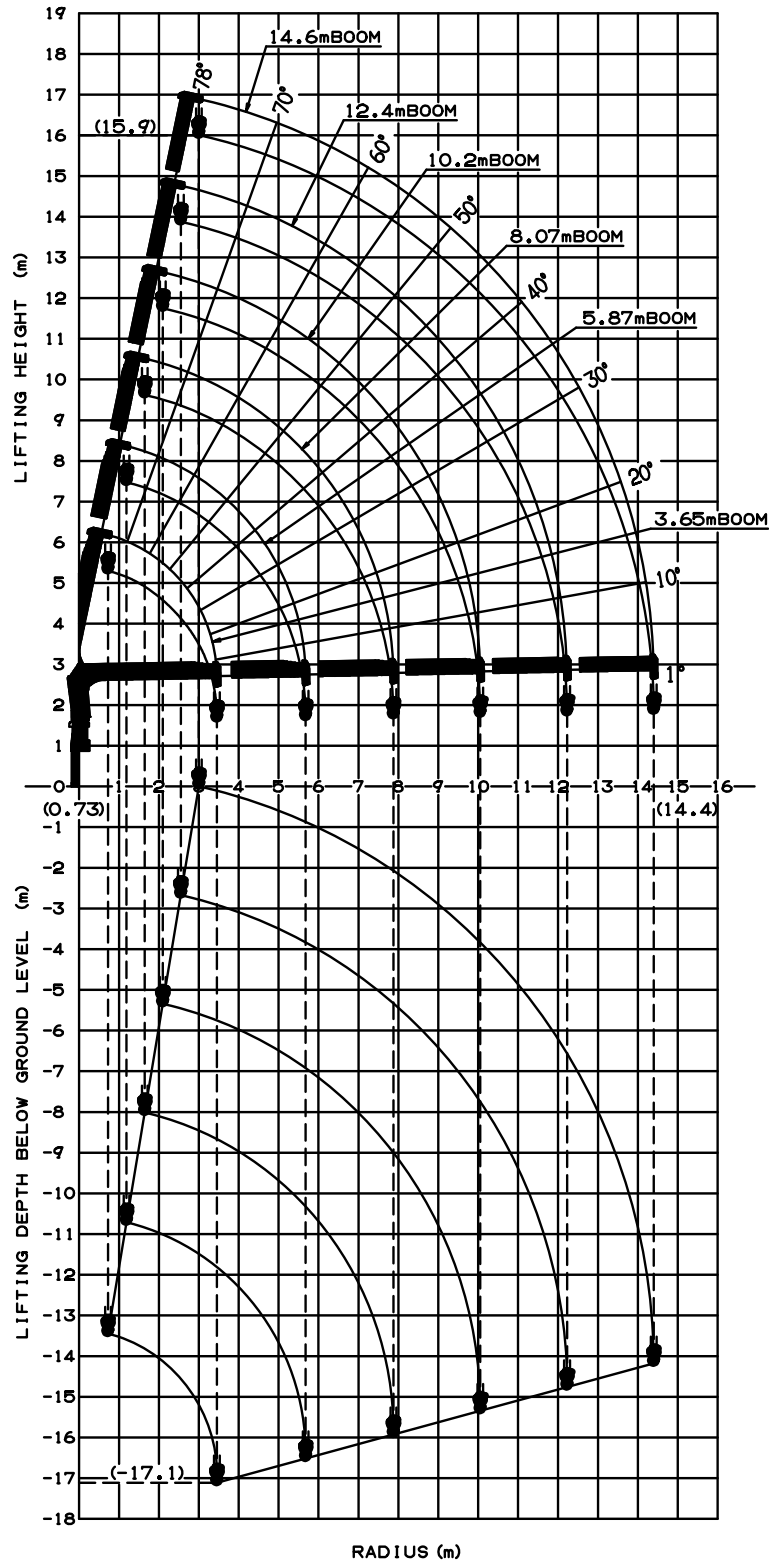

NOTE : The above lifting heights and boom angles are based on a straight (unladen) boom, and allowance should be made for boom deflection obtained under laden conditions.

DIMENSIONS

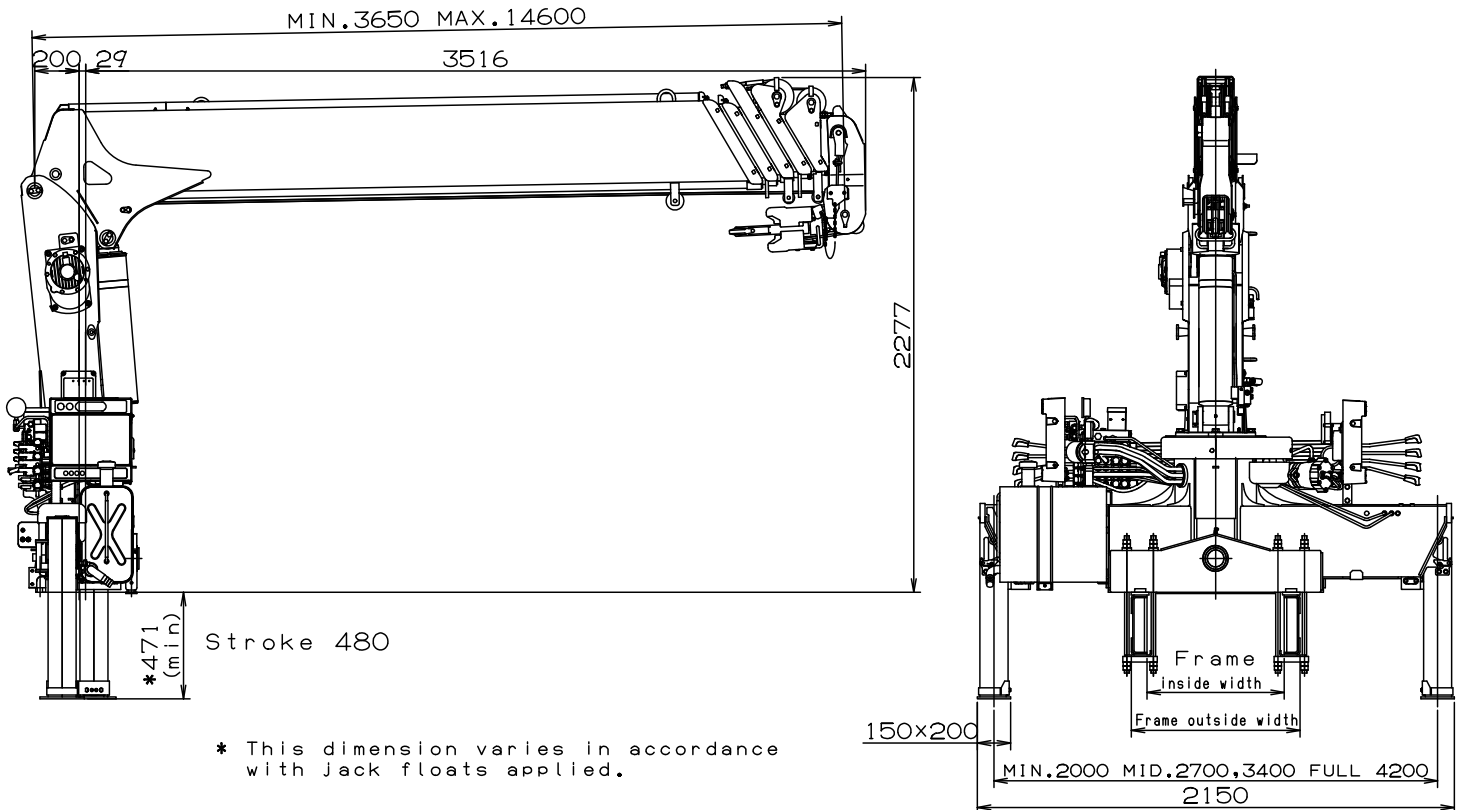

GENERAL DATA FOR SUITABLE TRUCKS

- Gross vehicle mass (including crane mass) ----- 8,000 to 15,000 kg
 - P.T.O. torque -----190 N-m{19.4 kgf-m} min.
 - P.T.O. revolution ----- Approx. 300 to 1,900 min⁻¹{rpm}
 - Width for crane mounting ----- Approx. 640 mm min.
 - Frame ----- Weight distribution and frame strength should be calculated for each truck
 - Frame width range (inside to outside) ----- Approx. 610 to 860 mm
 - Frame height (ground to frame top) ----- Approx. 1,070 mm max.
- (Height of crane mounting base can be changed by combination of jack floats and crane bases)