

Performance

Lifting height	10290.0 mm
Lifting height — on tyres	10290.0 mm
Rated capacity	3500 kg
Capacity (at max. height on tyres)	2500 kg
Capacity (at max. reach on tyres)	600 kg
Max. reach on tyres	6886.0 mm

Weights

Weight (unladen)	7220 kg
------------------	---------

Traction

Standard tyres	SOLIDEAL 405/70-20 14PR
1st gear / low range	4.2 km/h
1st gear / high range	20.5 km/h

Drive System

Transmission	Hydrostatic with electronic regulation
Main drive	Hydrostatic motor

Engine

Make / Model	Bobcat D34
Fuel	Diesel
Cooling	Coolant
Rated power (ISO 14396:2002) at 2400 RPM	75.0 HP
Rated power (ISO 14396:2002) at 2400 RPM	55.2 kW
Maximum torque at 1400 RPM	325.0 Nm
Number of cylinders	4
Displacement	3.40 L

Hydraulic System

Pump type	Gear pump with LS valve
Pump capacity	80.00 L/min
Relief valve pressure setting	255.00 bar

Cycle Times

Lift time - no load	12.4 s
Lower time - no load	7.0 s
Telescope in time at max. reach - no load	7.1 s
Telescope in time at max. height - no load	7.1 s
Telescope out time at max. reach - no load	13.0 s
Telescope out time at max. height - no load	13.0 s

Brakes

Engine braking	Hydrostatic
Parking and emergency brake	Passive brake

Fluid Capacities

Fuel tank	130.00 L
Hydraulic reservoir	71.00 L

Environmental

Operator noise level (LpA) (EN 12053)	75 dB(A)
Level of acoustic power (LWA)	104 dB(A)
Whole body vibration (EN 13059)	0.90 ms ⁻²

Load Charts

With forks and standard 405/70x20 tyres

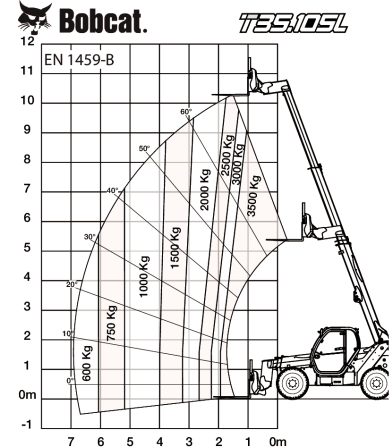

98884 G7

7294187

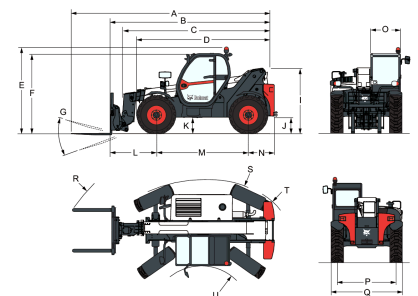
Dimensions

(-)	857.0 mm	(L)	1422.0 mm
(A)	6276.0 mm	(M)	2850.0 mm
(B)	5071.0 mm	(N)	799.0 mm
(C)	4936.0 mm	(O)	930.0 mm
(D)	4192.0 mm	(P)	1862.0 mm
(E)	2584.0 mm	(Q)	2264.0 mm
(F)	2389.0 mm	(R)	5025.0 mm
(G)	143.0°	(S)	5116.0 mm
(I)	1941.0 mm	(T)	3765.0 mm
(J)	415.0 mm	(U)	1245.0 mm