

SPS 20000

SANY PALFINGER

THE IDEAL LIFTING AND LOAD HANDLING SOLUTION FOR 3 AXLE TRUCKS

8.0t
Max Lifting
Capacity

17.7m
Max.
Outreach



TECHNICAL SPECIFICATIONS

SPS 20000

B (4 BOOM)

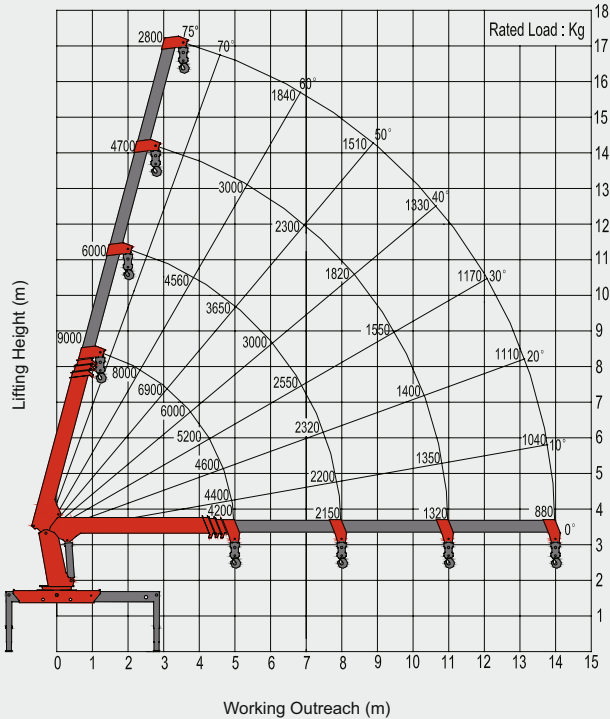

C (5 BOOM)

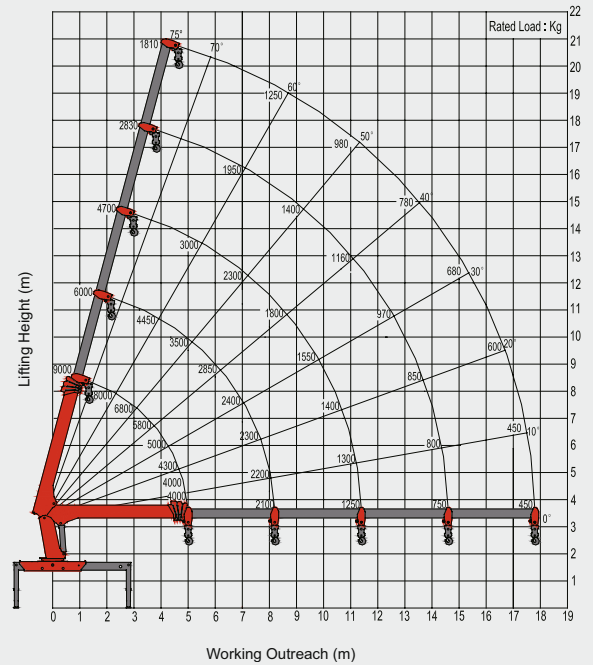

TECHNICAL SPECIFICATIONS

Model	SPS 20000 B	SPS 20000 C
Max. lifting moment [mt]	20.0	20.0
Max. lifting capacity [kg/m]	8000/2.5	8000/2.5
Number of booms [-]	4	5
Max. hydraulic outreach [m]	14.0	17.7
Max. lifting angle [°]	75	75
Slewing angle [°]	continuous	continuous
Stabilizer spread (std.) [mm]	5600	5600
Operating pressure [MPa]	28	28
Required oil flow [L/min]	70	70
Oil tank capacity [L]	200	200
Crane Weight [kg]	3820	4110

- High tensile strength extension booms to optimize the lifting height and the working range
- Best lift-to-weight ratio in the industry
- The wide outrigger span ensures the best stability in all mounting situations
- The standard package includes 2 working lights to ensure safe operation, day and night
- Optionally available is an over-load protection system to ensure safe crane operation
- SANY PALFINGER produces according to European Quality Standards to ensure the best reliability, performance, and safety in the industry
- Optimized for installation on 3 axle trucks
- A Safety Package is optionally available

DIMENSIONS

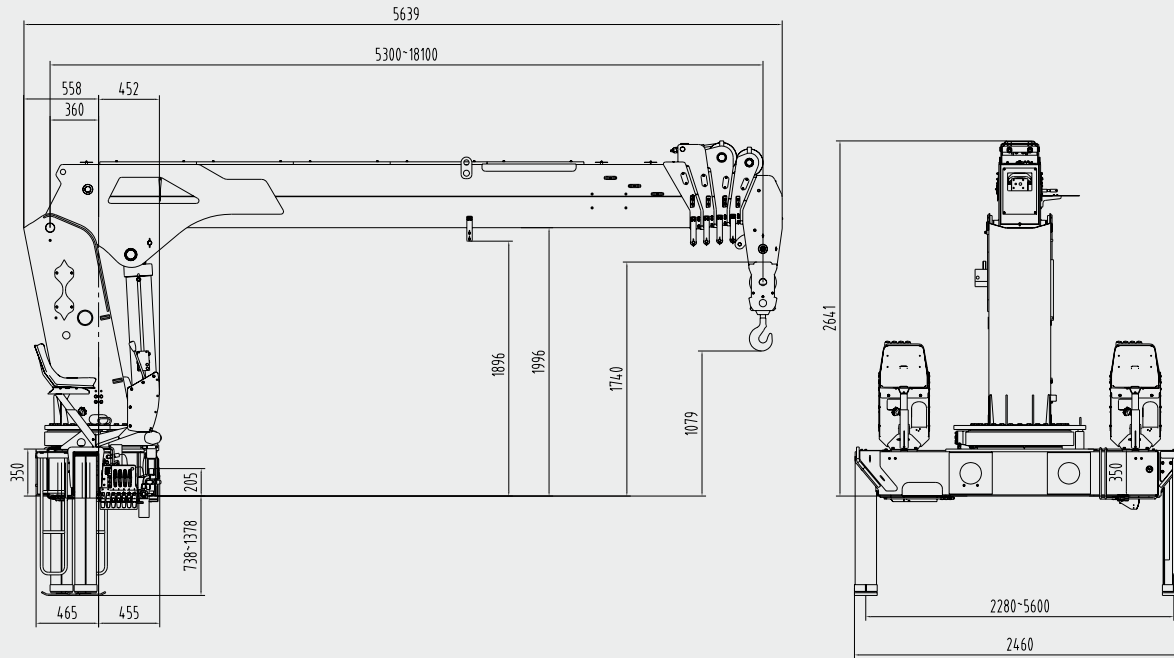

*The actual product dimensions can vary depending on the optional equipment

STANDARD FEATURES

HD Paint

HIGH DENSITY PAINT SYSTEM

- Demonstrates superior performance
- Long-term UV-resistance
- Attractive aesthetics



ERGONOMIC DESIGN

- Practical and Attractive
- SANY PALFINGER follows the general principles of ergonomics to ensure a comfortable and safe crane operation

POPULAR OPTIONS



OVERLOAD PROTECTION SYSTEM

- Built in safety function
- Stops all movements that could further increase the lifting moment



RADIO REMOTE CONTROL SYSTEM

- Allows to remotely control the crane
- Provides the best-possible overview of the loading process and ensures higher efficiency in use



HIGH PRESSURE AND RETURN FILTER

- Ensures proper functionality and lifetime
- Two oil filters are installed on each crane



ADVANCED PROPORTIONAL HYDRAULIC SYSTEM

- Allows the operator to use multiple functions simultaneously
- Increases working speed



TOP SEAT

- Optimal functionality and ergonomics
- Excellent visibility and easy operation



TWO SPEED WINCH

- Designed to maximize the efficiency

PROJECT ENGINEERING

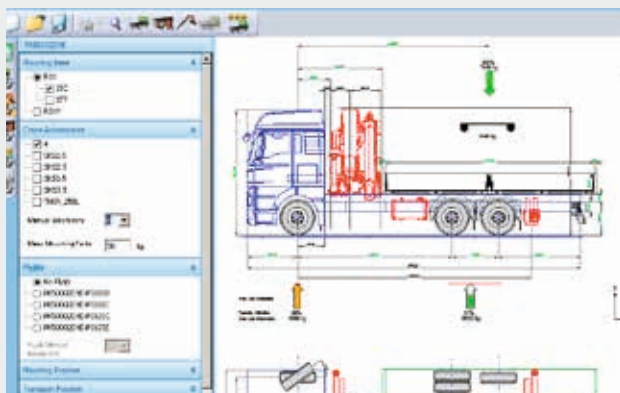

The SANY PALFINGER applications engineering team addresses the requests of our clientele from subframe design to stability calculations and provide the best vehicle integration solutions.

TECHNICAL SUPPORT



Service is SANY PALFINGER's top priority. Your products are supported by our highly trained, professional, and global service network.

COMPLETE VEHICLE INSTALLATIONS



Complete vehicle installations are provided directly from SANY PALFINGER. We ensure the most economic vehicle installations at the highest quality level.

EUROPEAN QUALITY



SANY PALFINGER produces according to European Quality Standards to ensure the best Reliability, Performance, and Safety in the Industry.

Authorized Dealer:

Sany Palfinger SPV Equipment Co; Ltd.
No 189 Huanghe Road,
Economic Development Zone Rudong, Jiangsu, China

T +86 513 8069 8069
www.sanypalfinger.com
sales@sanypalfinger.com

Applications shown in the leaflet do not always correspond to the standard specifications.
Design and specification are subject to change without prior notice. Dimensions may vary. Subject to technical changes, errors, and translation mistakes.