

# X6.4

TRACTOR OF THE YEAR® 2018  
BEST UTILITY  
WINNER



420 - 430 - 440 XTRASHIFT / VT DRIVE

 ENGLISH

  
**McCORMICK**









# McCORMICK X6.4: SPECIALIST IN PRODUCTIVITY, COMFORT AND DESIGN

McCormick has designed and developed the new X6.4 series with an ambitious goal: to create a range of highly customizable medium-power tractors to effectively meet the farmers' needs.

Born out of the extensive on-the-ground experience of Argo Tractors' engineers, the X6.4 tractor is designed to be truly versatile in any situation. The range offers the choice of two transmissions: Xtrashift with three-stage Powershift (H-M-L) and VT-Drive (CVT). Both tractor versions share the same cab, axles and hydraulic system.

The X6.4 sports the unmistakable modern and aggressive style of McCormick's latest-generation models, designed to give the tractors a powerful and compact look. The all-new four-post cab is engineered to provide exceptional all-round visibility and superior comfort.



The X6.4 series comprises six models: three with Xtrashift transmission and three with VT-Drive transmission.

All six models in the range are powered by Beta Power engines equipped with the Power Plus system that deliver power ratings from 121 to 140 hp.

The X6.4 tractors feature an electronically-controlled rear hitch with 5400kg maximum lift capacity, a four-speed PTO and a closed-centre hydraulic system that delivers a flow rate of 110 l/min.

A front hitch and PTO add greater versatility to the X6.4 tractor range, making it ideal for a wide variety of farming operations.

The cab is equipped with a mechanical suspension which, combined with the suspended front axle, ensures the operator superior ride comfort, whether in the field or on the road.

With a weight-to-power ratio of 37 kg/hp, the powerful X6.4 is ready to prove itself.

MODEL	POWER RATING (HP/KW)	POWER WITH POWER PLUS (HP/KW)	WHEELBASE (MM)	WEIGHT WITH RIGID AXLE (KG)	WEIGHT WITH SUSPENDED AXLE (KG)
<b>X6.420</b> XTRASHIFT	110/81	121/89	2540	4700	5200
<b>X6.430</b> XTRASHIFT	119/87.5	133/89	2540	4700	5200
<b>X6.440</b> XTRASHIFT	128/94	140/103	2540	4700	5200
<b>X6.420</b> VT-DRIVE	110/81	121/89	2540	5300	5800
<b>X6.430</b> VT-DRIVE	119/87.5	133/89	2540	5300	5800
<b>X6.440</b> VT-DRIVE	128/94	140/103	2540	5300	5800

## HIGHLIGHTS

- › McCormick's latest-generation design: modern and aggressive.
- › Deluxe cab: all-round visibility, first-class trims and ergonomics.
- › DSM touch screen monitor for control of all tractor functions, ISOBUS management and automatic guidance control.
- › Air-suspension driver's seat with swivel feature.
- › Mechanical cab suspension for superior comfort.
- › Fully opening transparent roof hatch for extra visibility during loader operations.
- › Sixteen work lights for superior illumination during night-time work.
- › Beta Power Tier 4 Final engines with Power Plus system delivering up to 140 hp.
- › SCR pollution control system with AdBlue tank meeting Tier 4 Final emissions regulations.
- › Two transmissions to choose from: Xtrashift with three-stage Powershift (H-M-L) or VT-Drive (CVT).
- › Four-speed rear PTO.
- › Rear hitch with 5400 kg lift capacity.
- › Front axle with independent suspension and integrated brakes.
- › Front hitch and PTO for enhanced tractor versatility.





**EXHAUST**

emissions - consumption  
page 29

**SATELLITE-BASED GUIDANCE**

PSM - EazySteer  
page 22

**DELUXE CAB**

comfort - instruments  
safety - electronics  
page 4

**HYDRAULIC SYSTEM**

PTOs - hitches - remote valves  
page 21

**ENGINE**

power - consumption  
page 26

**ISOBUS**

gestion des outils  
page 24

**FRONT HITCH**

PTOs - front loader  
page 18

**REAR HITCH**

electronically-operated  
page 16

**TRACTION**

front axle - brakes  
page 14

**TRANSMISSION**

VT-Drive - Xtrashift  
page 8





## DELUXE CAB: SUPERIOR VISIBILITY, ERGONOMICS AND COMFORT

The X6.4 impresses with the high level of comfort of its Deluxe cab. Large and easily accessible, the cab offers the operator a spacious and comfortable working environment. The fully adjustable driving position features an air-suspension seat, a telescopic steering column and a tilting instrument panel. All main controls are arranged in an intuitive and logical manner and conveniently placed within easy reach for

safe operation and maximum operator comfort. Featuring an automotive-style interior with a sound level of only 79 dB and a highly-efficient automatic climate control, the Deluxe cab is designed to reduce operator fatigue during long working days. A mechanical suspension can be supplied as an option for enhanced ride comfort.



Cab interior on version with **Xtrashift** transmission: tractor controls are placed on the right-hand side console.



Cab interior on version with **VT-Drive** transmission: tractor controls are placed on the right armrest of the driver's seat.





## HIGHLIGHTS

- › Ease of access to cab.
- › Spacious cab interior.
- › Four-post cab for all-round visibility.
- › Transparent roof hatch.
- › Automotive-style interior.
- › Fully adjustable driving position.
- › Ergonomically arranged controls.
- › Full set of creature comforts.
- › Optimum sound-proofing.
- › Highly-efficient climate control.
- › Mechanical cab suspension.
- › 16 halogen lights.



### DELUXE CAB WITH PANORAMIC VIEW

The Deluxe cab is a four-post design with flat-deck platform and rear-hinged doors designed to offer excellent all-round visibility for maximum ease and comfort of operation.



### FULL REAR VISIBILITY

The large back window and side-mounted rearview mirrors provide exceptional rear visibility, enhancing operator comfort and safety both in the field and on the road.



### SET OF FLOOD LIGHTS FOR NIGHT WORK

Sixteen powerful halogen lights provide exceptional flood lighting making night-time operation more efficient and safer.



### ERGONOMICALLY-ARRANGED CONTROLS

The in-cab controls for the 16 lights are conveniently integrated into the roof on the right-hand side, beside the radio.





**TRANSPARENT ROOF HATCH**

The transparent roof hatch provides extra visibility for loader operations. The roof hatch opens to allow cab ventilation. An adjustable roll-down shade for the front windshield protects the driver from direct sunlight and glare.



**OPTIMUM CLIMATE CONTROL**

A highly efficient automatic climate control integrated into the cab roof maintains the desired cab temperature whatever the outdoor weather conditions. The automatic climate controls are conveniently built into a roof console, on the drivers' left.



**RADIO AND TELEPHONE**

A Bluetooth RDS/MP3 radio, located to the right of the light controls, enables the driver to listen to music through either an MP3 player, an AUX cable or a USB flash drive. The system also allows the driver to make hands-free phone calls.



**CAB EQUIPPED WITH ALL CREATURE COMFORTS**

A refrigerated in-cab storage compartment is located on the driver's left. Refrigeration can be turned off via a switch. A practical bottle holder is conveniently placed on the driver's right.



**Made-to-measure driving position**

The X6.4 features a telescopic tilt-adjustable steering wheel designed to tilt with the instrument panel. The driver's seat comes in two versions: with mechanical suspension and fabric upholstery or with pneumatic suspension and upholstery in Alcantara, an easy-to-wash material that combines elegance and strength. The cab also features an upholstered buddy seat which neatly folds away to allow easier and safer access to the cab.

All controls can be easily identified enabling quick operation and adjustment. On the VT-Drive models, most controls are integrated into the right-hand armrest.





VT-1





# VT-DRIVE AND XTRASHIFT TRANSMISSIONS: EFFICIENCY AND VERSATILITY



McCormick's VT-Drive and Xtrashift transmissions have been designed, developed and tested to provide unequalled efficiency and versatility. McCormick trAansmissions are designed to effectively meet the farmers' needs for a variety of field, transport and livestock operations.





## VT-Drive trasmission: maximum comfort and productivity

The VT-Drive transmission is a continuously variable transmission (CVT) developed by Argo Tractors that provides three forward and two reverse working speeds. The planetary gears and the hydraulic clutches incorporated in the VT-Drive are designed to either reduce or increase the speed of rotation of the continuously variable gearbox.

The controls of the VT-Drive transmission are integrated into the multi-function armrest of the driver's seat. The ergonomically-designed VT Easy Pilot controller provides easy and intuitive control of the transmission allowing the operator to increase or reduce the tractor speed without depressing the accelerator pedal.

The controller enables the operator to drive the tractor and operate the implements through a variety of functions, such as the Remote Shuttle button which allows the operator to shift from forward to reverse without using the shuttle control lever adjacent to the steering wheel, making for faster headland turns and front loader operations. The controller further enables the operator to control the rear hitch fast raise lower function, to use the speed cruise control or to operate a hydraulic remote valve. All functions are clearly displayed on the instrument panel and on the DSM touch screen monitor.

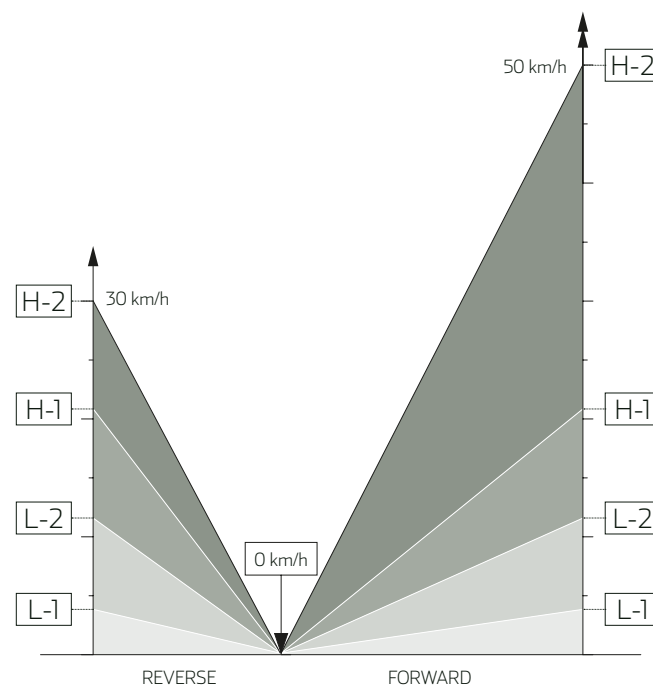

SPEED RANGE	MAXIMUM SPEED (FORWARD)
L-1	3 KM/H <sup>1</sup>
L-2	16 KM/H <sup>2</sup>
H-1	21 KM/H <sup>1</sup>
H-2	40 KM/H <sup>2</sup> o 50 KM/H <sup>2-3</sup>

SPEED RANGE	MAXIMUM SPEED (REVERSE)
L-1	3 KM/H <sup>1</sup>
L-2	16 KM/H <sup>2</sup>
H-1	21 KM/H <sup>1</sup>
H-2	25 KM/H <sup>4</sup>

- 1) Factory pre-set speeds modifiable by operator where allowed
- 2) Speed non modifiable by operator
- 3) Maximum settable speed in "Field" mode is 33 km/hr





### VT-DRIVE, HIGH VERSATILITY OF USE

Designed to be highly efficient and extremely versatile, the VT-Drive transmission features three operating modes that can be selected via the potentiometer integrated into the armrest:

1. **Auto Mode:** the software controls the engine speed and transmission ratio that are most suited to achieve the speed set via the potentiometer, either on Field or Transport mode.
2. **PTO Mode:** this extension of the automatic mode ensures that the engine speed remains constant regardless of the load, enabling the implement connected to the PTO to work at the required rpm.
3. **Manual Mode:** the operator controls the transmission speed and engine rpm manually via the controls on the armrest.

Switching between modes can be done only when the tractor is stationary.

### LEVER-OPERATED REVERSE POWER SHUTTLE

A – Lever forward: forward speeds.

I – Idle: not Arunning position.

R – Lever backward: reverse speeds.

N - Neutral: neutral position.

P - Parking: park lock engaged, optional.

The reverse power shuttle features a potentiometer to adjust shuttle response.

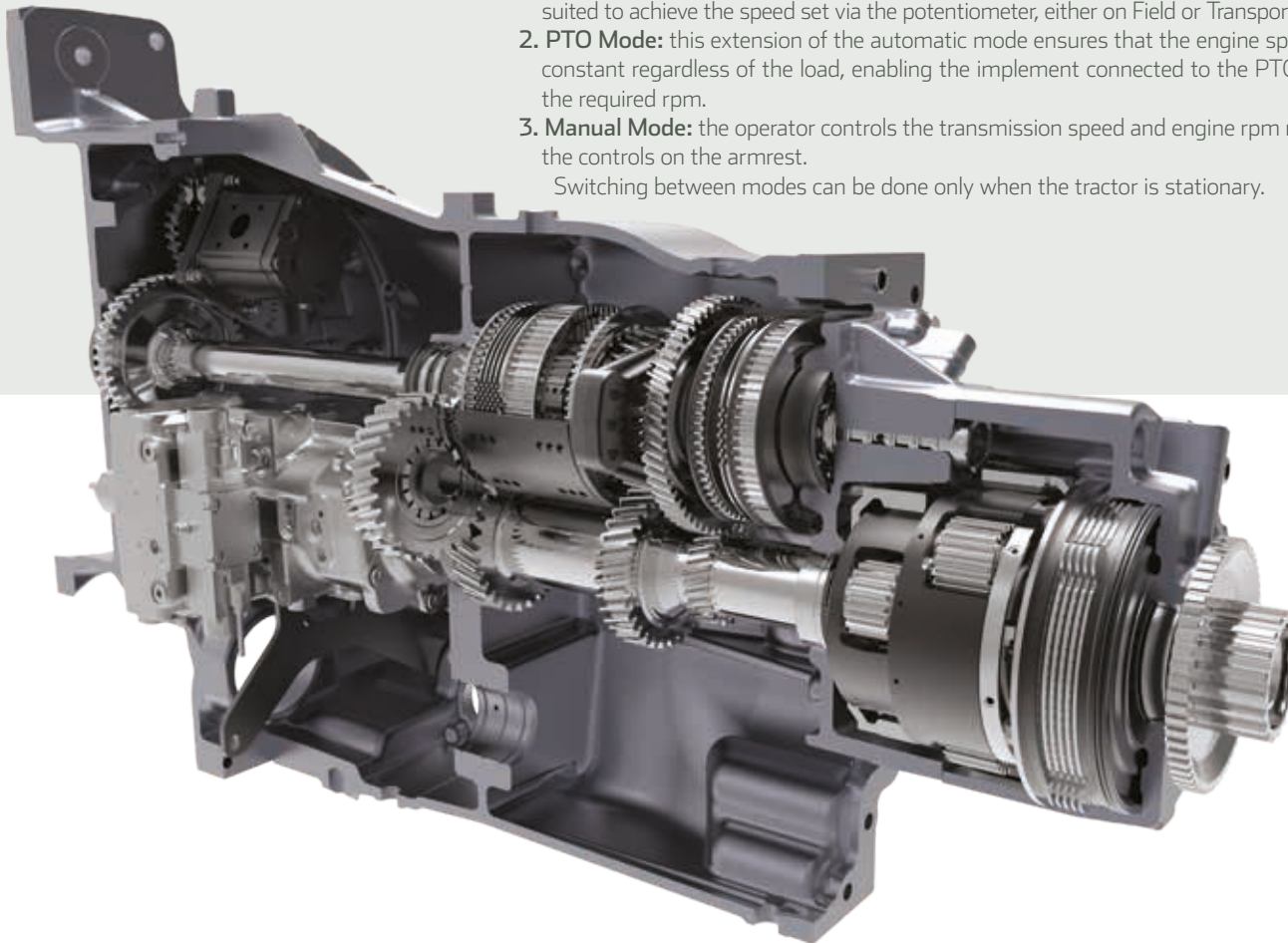



## Xtrashift transmission for maximum efficiency

The Xtrashift transmission stands for efficiency: it triples the 12 gears of the basic gearbox providing a total of 36 forward speeds and 12 reverse speeds. A creep speed unit with 48 forward and 16 reverse gears and speeds as low as 290 m/h is available as an option.

The Xtrashift transmission is simple to operate: gears and ranges are shifted by means of levers located on the driver's right, while the shuttle control lever is on the left-hand side of the steering column. The declutch control button and the power shuttle allow the operator to respectively change gear and shift from forward to reverse without using the clutch pedal.

The power shuttle features a potentiometer for power shuttle response adjustment.

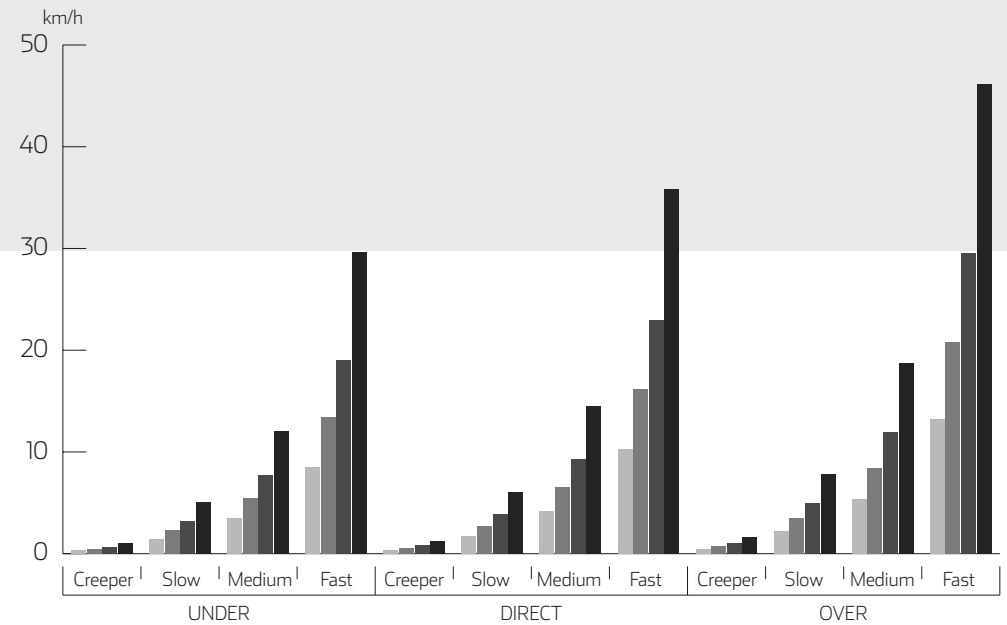



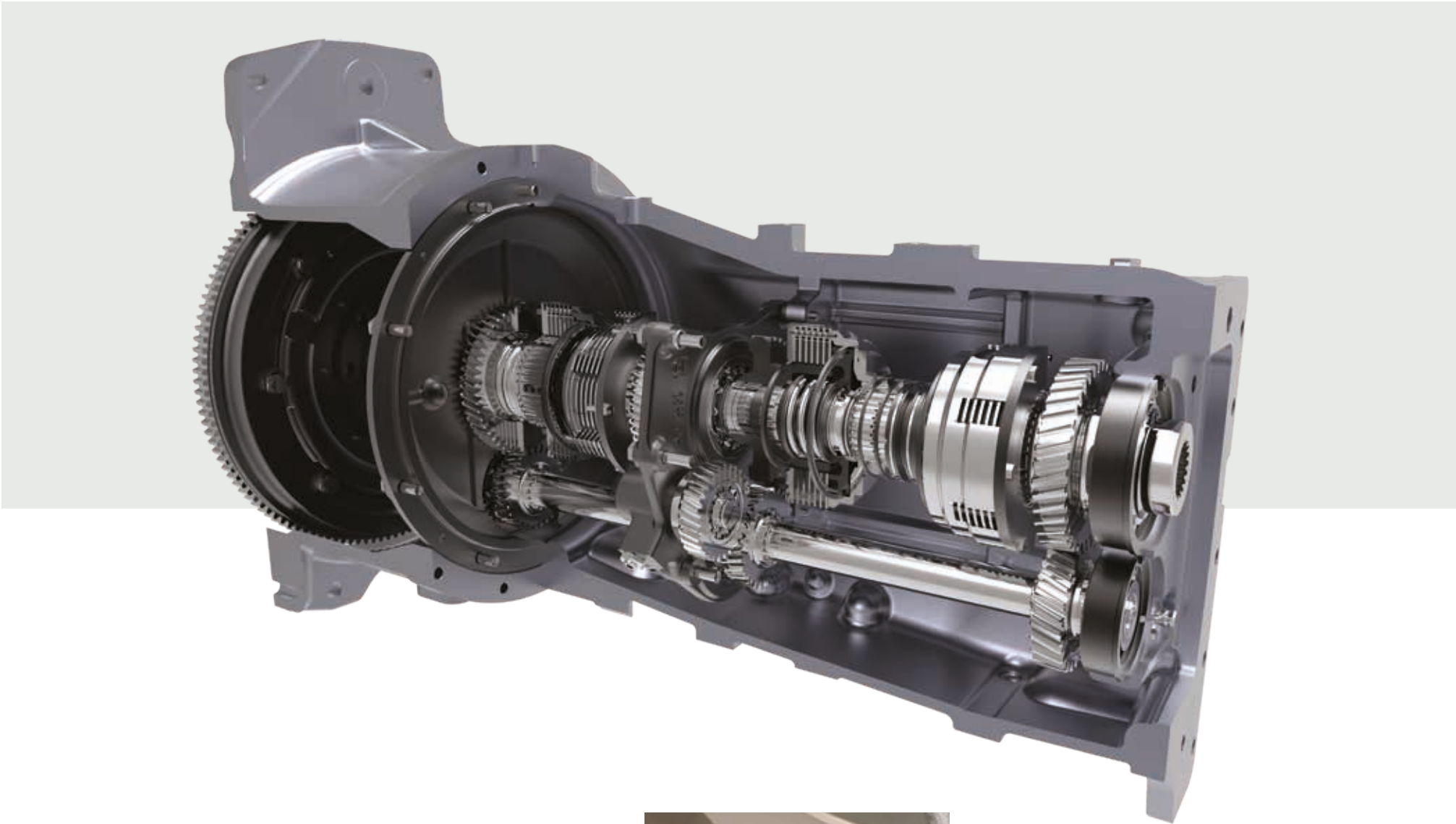

**ECO FORTY CUTS DOWN CONSUMPTION AND NOISE**

The X6.4 range features the Eco Forty mode that provides a top speed of 40 km/h at 1900 rpm, resulting in increased fuel economy and lower noise during road transport. Where legally permitted, a top speed of 50 km/h can be reached with the Top Fifty mode.



**PARK LOCK, SAFETY GUARANTEED**

Optionally, the power shuttle can be equipped with park lock, a mechanical locking device integrated into the gearbox. The park lock prevents the tractor from moving when the engine is off, making it ideal when parking on slopes.





## Excellent traction, manoeuvrability and comfort on all terrains

The X6.4 offers outstanding traction and excellent manoeuvrability ensuring optimum grip and stability for superior driving comfort in the field and on the road. The heavy-duty front axle is equipped with full hydraulic locking differential and electro hydraulic four-wheel drive engagement ensuring maximum efficiency and safety on all terrains, including when operating a front hitch or a front loader. The rear axle is equally sturdy and reliable. The wide oscillation of the front axle, the excellent ground clearance and the 55-degree steering angle make the X6.4 highly manoeuvrable in any situation, while the hydrostatic drive delivers smooth steering control even at low engine rpm.





**INDEPENDENT FRONT SUSPENSION**

The X6.4 comes standard with a rigid-mounted front axle and can be optionally equipped with an electronically-controlled independent front suspension for extra comfort. The independent front axle system is designed to allow each wheel to absorb impacts independently of one another and enables, in addition, forecarriage height adjustment. This makes for better grip and greater stability compared to conventional axles, resulting in improved driving safety. The independent front suspension allows faster travel speeds and enhances operator comfort, whether in the field or on the road.

**AUTOMATIC 4WD AND DIFFERENTIAL LOCK ENGAGEMENT FOR EASY HEADLAND TURNING**

All X6.4 Series models are equipped with combined front and rear differential locks to reduce wheel slip and maximise traction. The system is designed to automatically engage or disengage the differential lock and the four-wheel drive during headland operations, resulting in greater operator's convenience and safety.

**SMOOTH AND PRECISE BRAKING**

X6.4 tractors are equipped with wet multi-disc front and rear axle brakes. These are power boosted to reduce the effort required by the operator, while ensuring efficient braking on all four wheels. Optionally, the tractor can be equipped with either hydraulic or pneumatic trailer brakes.

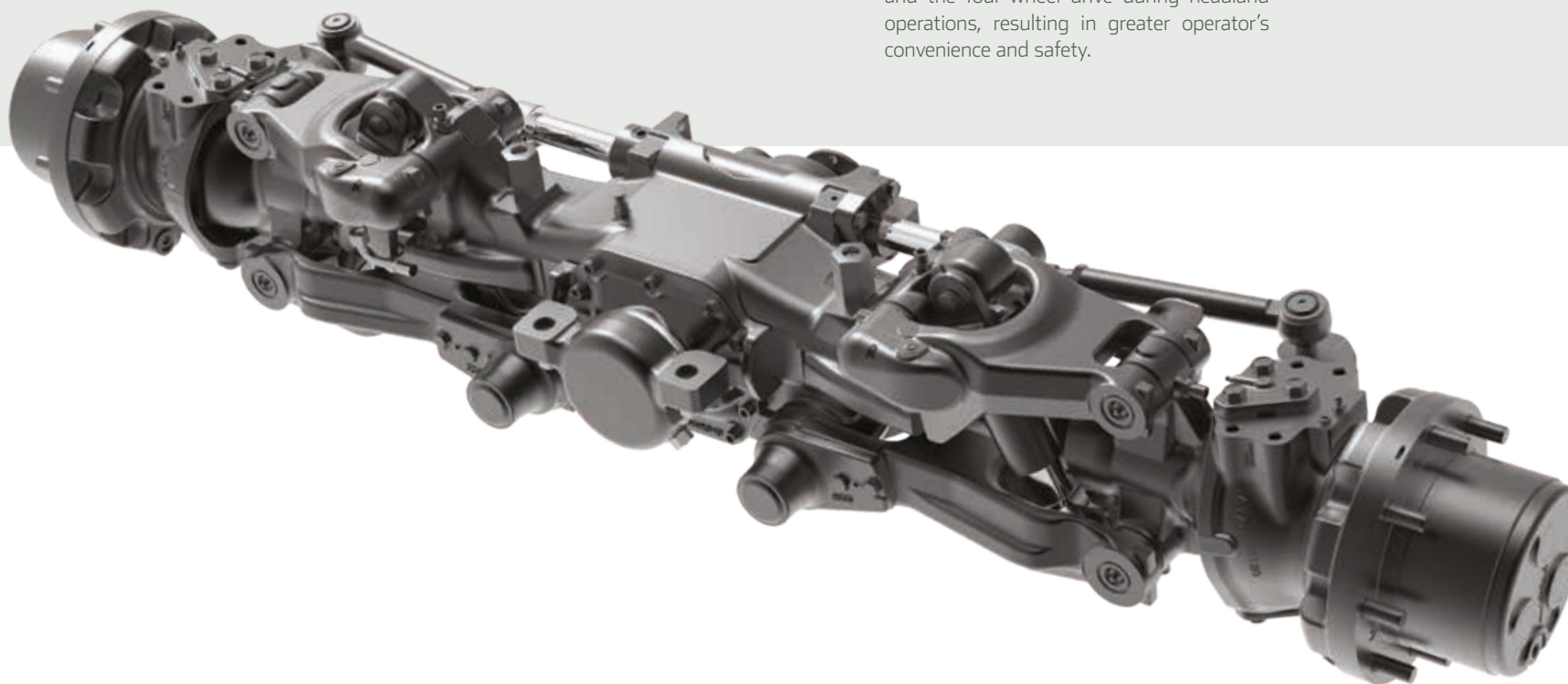



# GREAT VERSATILITY FOR ENHANCED PRODUCTIVITY



The new McCormick X6.4 series offers farmers the possibility to customize their tractor to suit their specific needs. Thanks to its versatility, the X6.4 can be fitted simultaneously with a front hitch and PTO and a front loader for maximum productivity.



## Easy-to-use electronically-operated rear hitch

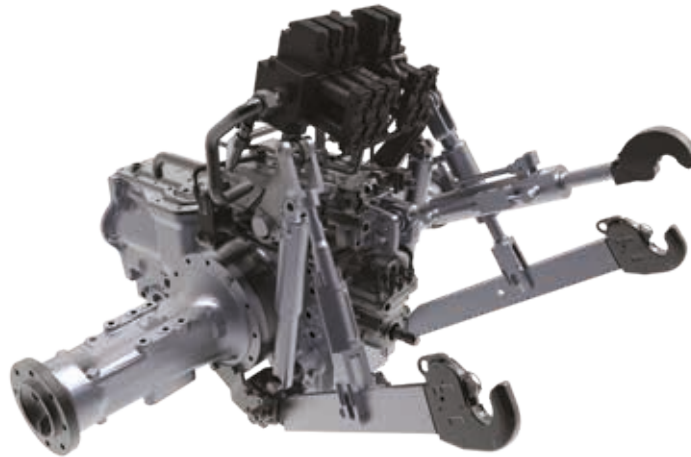

On the VT-Drive version, the raise/lower control of the rear hitch is conveniently located on the Easy Pilot controller for precise implement operation. External hitch controls are located on the rear fenders making it easier to attach implements from the ground. Offering a maximum lift capacity of 5400 kg, the rear hitch is equipped with lower link draft sensing for accurate implement control. All X6.4 tractors are equipped with a hitch dampening function to prevent pitching when travelling with hitch-mounted implement.



### CHOICE OF TWO- OR FOUR-SPEED PTO

The PTO offers standard two speeds: 540/540e rpm or 540/1000 rpm. A four-speed PTO providing 540/540e/1000/1000e rpm is available as an option. An hydraulically operated clutch enables smooth and modulated engagement of the PTO, ensuring a soft start-up of the implement. The X6.4 series is equipped with the Power Plus system, which automatically increases power available when the PTO is operational. This enables the engine to maintain a constant power as the load varies, allowing optimum use of the PTO for enhanced tractor performance and productivity. External PTO and hitch controls are located on the rear fenders making it easier to attach implements from the ground.

### AUTO PTO FUNCTION

The Auto PTO feature will automatically disengage and reengage the PTO at three-point linkage heights set by the operator. This gives the operator precise control of the implement during headland turns.





## McCormick M100 front loader: powerful and versatile

Designed to be integrated into the X6.4 tractor range, the McCormick M100 front loaders are built from HLE (High Limit Elasticity) steel, a material capable of withstanding high loads thanks to its mechanical properties.

The main strong points of the M100 loader are:

- › Hydraulic lines hidden inside the loader arms to ensure unobstructed view during operation.
  - › The piping of the hydraulic system is rigid to reduce oil overheating during intensive use and to simplify maintenance operations.
  - › A position indicator allows operator to quickly determine implement position.
  - › Used in combination with a Euro Hitch tool carrier, the loader can be fitted with a wide range of implements.
- › Maximum lift capacity: 1880 kg.
  - › The loader features a suspension with two nitrogen-charged accumulators placed between the cylinders that ensures a smooth ride at all times.
  - › The X6.4 is equipped with supports designed to make fitting and removal of the M100 loader easier.
  - › M100 loaders can be used in conjunction with a front-mounted hitch.

The X6.4 further features a conveniently placed controller and a high-visibility transparent roof hatch allowing the operator to comfortably sit in the driving position while working with the loader fully raised. The X6.4 and its M100 front-end loader are really a perfect match that will ensure maximum productivity in any task.



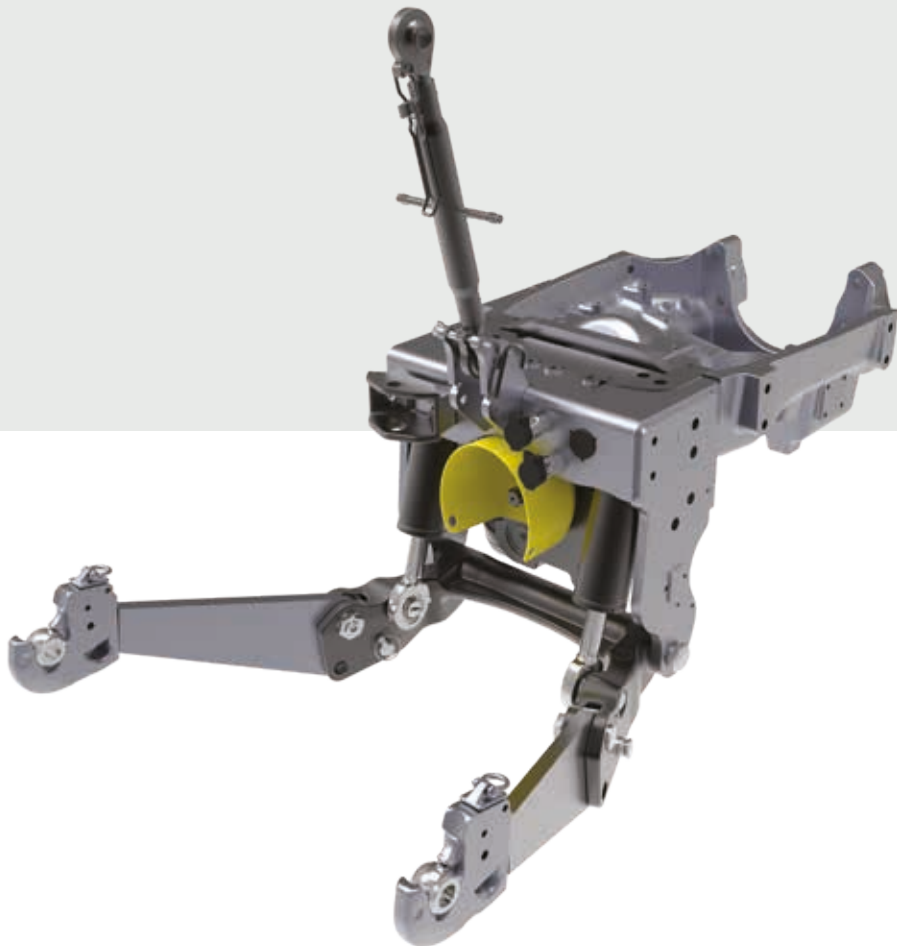

## Front hitch and pto for maximum flexibility

A front hitch and PTO are available as an option to add greater versatility to the tractor for applications using front-mounted implements and rear and front implement combinations, further enhancing the versatility of X6.4 tractor range. Offering a maximum lift capacity of 3400 kg, the front hitch is Category II and features raise/lower and float controls. The 1000-rpm PTO is electro-hydraulically engaged via a pushbutton. External PTO and hitch controls are located on the rear fenders making it easier to attach implements from the ground.



# POWERFUL HYDRAULIC SYSTEM FOR HIGH PERFORMANCE

The X6.4 with Xtrashift transmission features an open-centre hydraulic system with a flow rate of 66 l/min which suits most operating requirements.

The X6.4 with VT-Drive transmission features a closed-centre hydraulic system with a flow rate of 110 l/m. This system features a variable-displacement pump that delivers exactly the quantity of oil that the system requires, thereby eliminating unnecessary power waste. A closed-centre system is also available as an option for the Xtrashift version. A pump with a flow rate of 38 l/min operates the steering system, enabling smooth and precise turning, even under the most exacting conditions, resulting in enhanced operator comfort and productivity.





## Remote valves for any application

The X6.4 with Xtrashift transmission features five remote valves. Two valves are electro-hydraulically controlled via the multi-function controller and the other three are mechanically operated. The models with VT-Drive are equipped with five electro-hydraulically controlled load-sensing remote valves. Both transmission configurations offer four types of remote valves to suit different operating needs:

- › **Standard:** double-acting.

- › **Kick-out:** with automatic release.
- › **Floating:** for implements that follow the ground contour
- › **Hydraulic motor:** for the use of hydraulic motors.

Each of the above options enables the tractor to work with the front hitch and front loader, as well as with the rear hitch and a variety of rear-mounted implements. The high-quality quick-release couplings, mounted on both the front and rear of the tractor, are easily accessible for convenient and fast operation.





**SATELLITE-BASED GUIDANCE,  
HIGHER ACCURACY FOR GREATER PRODU**



The optional satellite-based guidance system is controlled via a dedicated 8.4" touchscreen monitor in conjunction with a satellite antenna fitted on the roof of the tractor cab.

The monitor manages two functions:

1. The Precision Steering Management system, which provides precise steering response, delivering up to 2cm pass-to-pass accuracy. Such a high level of accuracy greatly increases productivity per unit of worked area. Supplied in conjunction with the satellite guidance system is also the Eazysteer quick steering system, which allows the tractor to make a complete turn with just a quick turning of the steering wheel. This avoids multiple turns of the steering wheel, thereby improving the ride comfort and optimising the working time.
2. Configuration and control of the ISOBUS system with management of advanced features such as the Task & Section Controller.

CTIVITY



The satellite antenna placed on the cab roof receives the GPS signal.



The electronic steering wheel allows precise steering delivering up to 2cm pass-to-pass accuracy.



The 8.4" touch screen monitor for management of satellite-based guidance and ISOBUS system.



# ISOBUS FOR SIMPLE AND EFFICIENT IMPLEMENT CONTROL



The X6.4 range can be optionally equipped with an ISOBUS system, a protocol designed to allow communication between tractor, implement and on-board computer, enhancing operating efficiency and productivity. The operator can manage the operating parameters and performance of the implement via a simple touch screen monitor, without the need to install a dedicated control unit inside the cab.

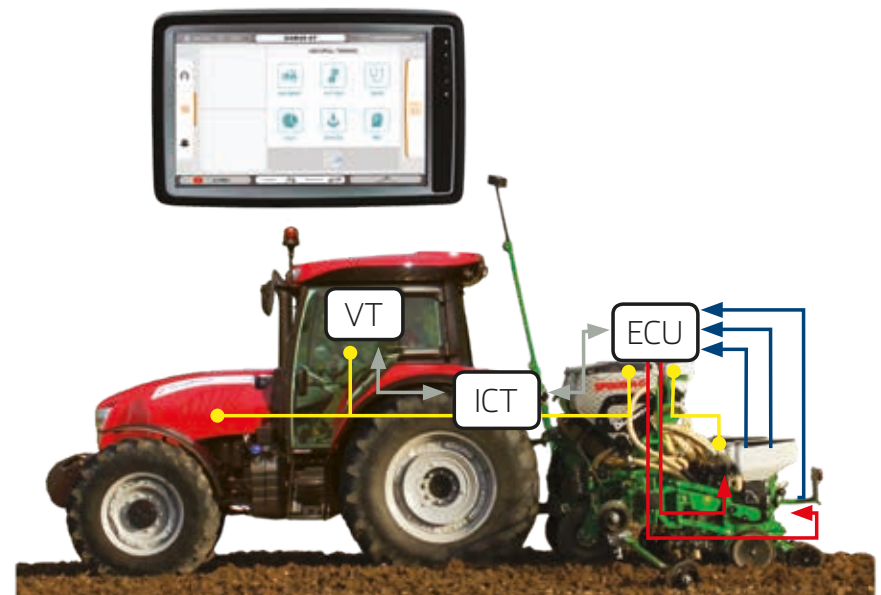



## Benefits of satellite-based guidance and ISOBUS system

The satellite-based guidance allows operator to set the working track with a maximum error of 2 cm: a degree of accuracy that even the most expert operators cannot achieve. The satellite-based guidance and the ISOBUS system enable the X6.4 to maximise efficiency and productivity:

- › A smaller number of passes minimizes the working time while ensuring accurate operation at all times.
- › Reducing the travelled distance reduces tractor and implement wear and saves fuel.
- › Fields are planted or sprayed without skips or overlaps; this minimizes product use while maximizing crop yield.
- › Report and pre-setting operations become more user-friendly and can be done from home. This eliminates the need for expert operators, thus reducing operating costs.
- › Each implement operation is controlled with extreme accuracy. Implement can also be controlled via an electronic automatic adjustment feature.







# BETAPOWER ENGINES: DESIGNED FOR POWER

The X6.4 tractors are powered by 4.5L, 16-valve, 4-cylinder Beta Power turbocharged engines with common rail injection system. These engines meet the Tier 4 Final emission regulations using the Selective Catalytic Reduction SCR + DOC Diesel Oxidation Catalizer, an exhaust gas after-treatment technology that reduces exhaust emission without compromising the tractor performance.

**X6.4.420** with engine power of 121/89 hp/kW

**X6.4.430** with engine power of 133/98 hp/kW

**X6.4.440** with engine power of 140/103 hp/kW









## Power Plus for extra power

The Power Plus system is designed to electronically adjust the engine power to respond to varying load conditions. The system is activated when, during transport or PTO work, the tractor speed exceeds 15 km/h; in this case, the Power Plus provides extra power to keep tractor speed constant. The Beta Power engines that power the X6.4 range are also equipped with common rail, a computerized fuel injection system that monitors the engine to always deliver the exact amount of fuel needed. The common rail technology reduces consumption while maximizing performance.

Benefits of the Power Plus system:

- Superior performance on the road
- Maximum power for implement operation
- Fuel saving
- Less mechanical wear

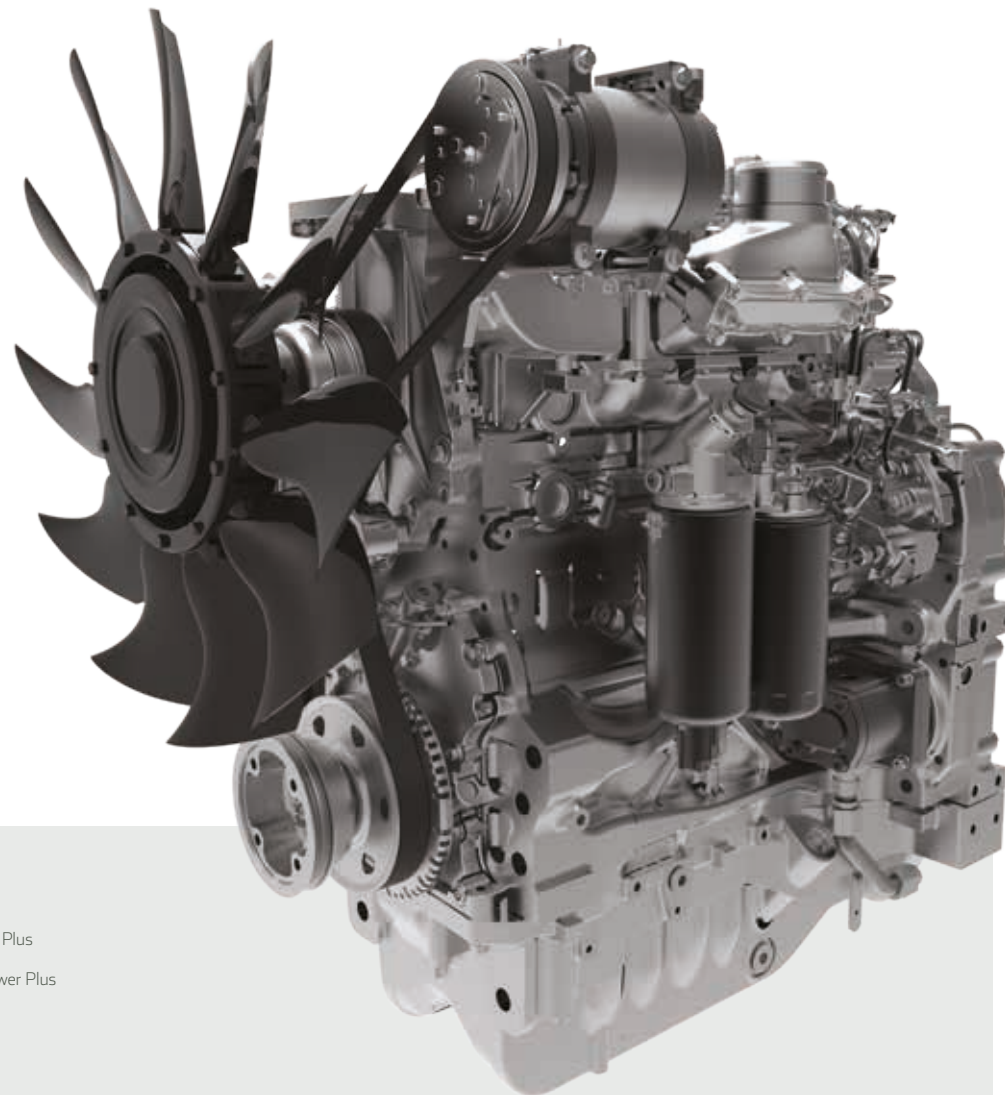

McCORMICK X6.4	MAXIMUM TORQUE WITH POWER PLUS	MAXIMUM TORQUE SPEED WITH POWER PLUS
X6.420	495 Nm	1400
X6.430	545 Nm	1400
X6.440	577 Nm	1400

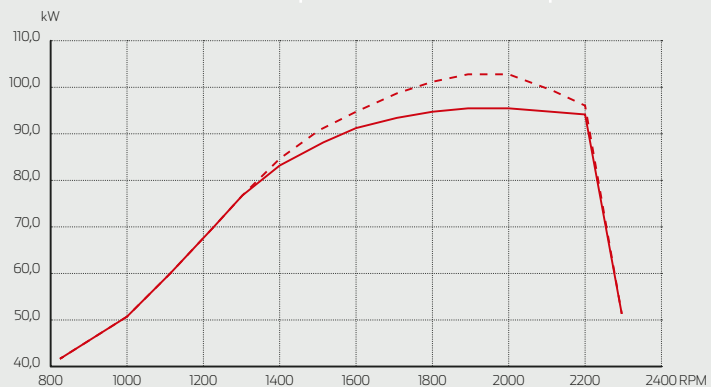

— with Power Plus  
 - - - without Power Plus

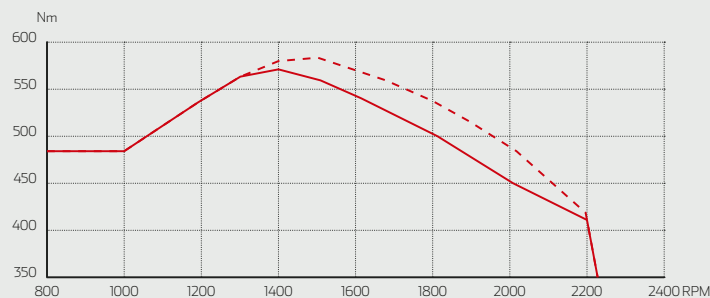

## SCR+DOC system to cut down on exhaust emissions

The SCR technology, or Selective Catalytic Reduction, utilizes AdBlue fluid to reduce engine exhaust emissions. The fluid is injected from a separate tank into the exhaust system and then conveyed to the SCR catalytic converter where it reacts with exhaust gases, thus reducing significantly the NO<sub>x</sub> emissions. The SCR system, used in conjunction with a DOC catalytic converter – a passive oxidation catalyst that reduces primary pollutants – ensures compliance with the strictest emissions regulations. The optimised electronic fuel injection and the enhanced combustion efficiency, combined with the SCR+DOC system, allow the Beta Power engines to deliver more power and torque backup with outstanding fuel economy, resulting in greater flexibility of use.







# QUICK MAINTENANCE TO BE IMMEDIATELY UP AND RUNNING

1. **Oil filler cap** is placed in the lower part of the engine, so topping up/filling of engine oil can be done without opening the hood.
2. **Engine air filter** is positioned in such a way as to make cleaning and replacement easier.
3. **Cooling radiators** open fully from a single latch to allow fast, accurate and easy cleaning in dusty conditions.
4. **Fuel and AdBlue tanks** are conveniently placed to allow quick filling. Tank caps have different colours.
5. **In-cab air filter** is easily accessible for maintenance.
6. **Oil level in the Xtrashift** transmission can be conveniently checked through the oil filler cap with dipstick placed on the rear of the tractor.
7. The **oil of the VT-Drive** transmission is contained in two separate chambers: one contains the CVT assembly and is located on the right-hand side of the transmission bridge, the other is on the rear of the tractor. Oil level in both chambers is checked via the oil filler cap with dipstick.
8. **Windscreen wiper fluid** reservoir is located on the back of the cab.

Designed to deliver maximum efficiency and reliability, the X6.4 range offers a variety of solutions to simplify and expedite maintenance. For example, the tilt-up hood is designed to open wide to provide easy access to the engine compartment for service and maintenance.







## McCORMICK SPARE PARTS AND SERVICE, TO GIVE YOU THE BEST ALWAYS

McCormick is also worldwide recognized as a reliable supplier of high-quality spare parts and after-sales services. Developed by the same engineers who develop McCormick tractors, genuine McCormick parts are designed and manufactured to the highest quality standards to ensure tractors reliable performance and maximum safety. Spare parts are delivered promptly and efficiently to McCormick's dealers on the same day of order. Each part comes with a 12-month warranty and bears a

non-falsifiable hologram which certifies its build quality and genuineness. Original McCormick parts are not only reliable but also convenient, as they enhance the working quality and efficiency of the X6.4 tractors. After-sales service is handled by our dealers through a team of highly-skilled, solution-oriented technicians who avail themselves of the latest diagnostic techniques. Choosing McCormick means choosing excellence.









# McCORMICK, INNOVATORS BY TRADITION



Cyrus Hall McCormick was born in Virginia, United States, in 1809. As a pioneer in engineering, McCormick had a stunning ability to mechanize farm work, as he demonstrated when, in 1831, he invented the first mechanical reaper.

The McCormick company was established in 1847. It produced wheat harvesters. Starting from 1866, the company adopted the colour red which from then on would distinguish McCormick around the world. In 1871, McCormick manufactured the greatest number of machines than any other company: 250 reapers per day. The first tractor, the Mogul 8-16, was launched in 1910. In those years, the company opened up factories in Canada, Great Britain, Germany, France and Sweden.

In the following years, the company was bought and sold various times. In 2001, McCormick was acquired by the Argo Group, which re-launched the brand under the name McCormick Tractors International Limited.

Today, McCormick is a world leader in the tractor industry and its name stands for uncompromised technology and innovative design. Thanks to heavy investments in research and development, the new generation of McCormick tractors is now positioned at the top of the market for performance and innovation. Farmers look for performance, reliability and versatility and this is exactly what McCormick offers its customers to maximize their productivity.



	<b>X6.420</b>		<b>X6.430</b>		<b>X6.440</b>		<b>X6.420</b>	<b>X6.430</b>	<b>X6.440</b>
	<b>XTRASHIFT</b>		<b>XTRASHIFT</b>		<b>XTRASHIFT</b>		<b>VT-DRIVE</b>	<b>VT-DRIVE</b>	<b>VT-DRIVE</b>
	<b>STD</b>	<b>LS</b>	<b>STD</b>	<b>LS</b>	<b>STD</b>	<b>LS</b>	<b>LS</b>	<b>LS</b>	<b>LS</b>
<b>ENGINE</b>									
TIER 4 INTERIM / STAGE 3B			BETAPOWER		BETAPOWER		BETAPOWER		BETAPOWER
ELECTRONIC HIGH PRESSURE COMMON RAIL			●		●		●		●
TURBO/AIR-TO-AIR INTERCOOLER			●		●		●		●
MAX. ENGINE POWER (ISO RATING)	HP/KW	114/84		121/89		130/95.5	114/84	121/89	130/95.5
MAX. ENGINE POWER WITH POWER PLUS (ISO RATING)	HP/KW	121/89		133/98		140/103	121/89	133/98	140/103
RATED ENGINE SPEED	RPM	2200		2200		2200	2200	2200	2200
MAX. TORQUE WITH POWER PLUS	NM	495		545		577	495	545	577
ENGINE RPM @ MAX. TORQUE WITH POWER PLUS	RPM	1400		1400		1400	1400	1400	1400
BORE / STROKE	MM	104 / 132		104 / 132		104 / 132	104 / 132	104 / 132	104 / 132
DISPLACEMENT / NO. OF VALVES / NO. OF CYLINDERS	CM <sup>3</sup>	4500/16/4		4500/16/4		4500/16/4	4500/16/4	4500/16/4	4500/16/4
S.C.R. EXHAUST SYSTEM			●		●		●		●
ADBLUE TANK CAPACITY	L	25		25		25	25	25	25
FUEL TANK CAPACITY	L	180		180		180	180	180	180
<b>CLUTCH</b>									
MULTI-DISC WET CLUTCH			●		●		●		●
DECLUTCH FUNCTION: BUTTON-OPERATED CLUTCH CONTROL			●		●		—		—
<b>TRANSMISSION</b>									
XTRASHIFT + SPEED FOUR + REVERSE POWER SHUTTLE: 36FWD+12REV (3 POWERSHIFT SPEEDS)			●		●		—		—
XTRASHIFT + SPEED FOUR + CREEPER + REVERSE POWER SHUTTLE: 48FWD+16REV			○		○		—		—
VT-DRIVE CONTINUOUS VARIABLE TRANSMISSION			—		—		●		●
ECO FORTY (40 KM/H) AT REDUCED ENGINE SPEED			●		●		●		●
TOP FIFTY (50 KM/H)			●		●		●		●
REVERSE POWER SHUTTLE			●		●		●		●
SHUTTLE MODULATION CONTROL: POTENTIOMETER FOR ADJUSTMENT OF POWER SHUTTLE RESPONSE			●		●		●		●
PARK LOCK			○		○		●		●
<b>POWER TAKE-OFF</b>									
WET MULTI-DISC PTO CLUTCH			●		●		●		●
ELECTROHYDRAULIC ENGAGEMENT			●		●		●		●
2 SPEEDS: 540/540E RPM			●		●		●		●
2 SPEEDS: 540/1000 RPM			○		○		○		○
4 SPEEDS: 540/540E/1000/1000E RPM			○		○		○		○
1"3/8 (34.9MM) PTO SHAFT WITH 6 SPLINES			●		●		●		●
1"3/8 (34.9MM) PTO SHAFT WITH 21 SPLINES			○		○		○		○
GROUND SPEED PTO			○		○		○		○
<b>FRONT 4WD AXLE</b>									
ELECTROHYDRAULIC 4WD ENGAGEMENT			○		○		○		○
RIGID TYPE			●		●		●		●
ELECTRONICALLY-CONTROLLED HYDRAULIC SUSPENSIONS			○		○		○		○
MAX STEERING ANGLE			55°		55°		55°		55°
ELECTROHYDRAULIC TWIN-LOCK DIFFERENTIAL LOCK			●		●		●		●
<b>BRAKING SYSTEM</b>									
ANNULAR PISTON REAR BRAKES			●		●		●		●
AUTOMATIC 4WD ENGAGEMENT ON BRAKING			●		●		●		●
WET MULTI-DISC FRONT BRAKES			○ ●		○ ●		○ ●		○ ●
IBS - INTEGRAL BRAKING SYSTEM			●		●		●		●
HYDRAULIC TRAILER BRAKING			○		○		○		○
PNEUMATIC TRAILER BRAKING			○		○		○		○
<b>HYDRAULIC HITCH</b>									
CONTROL FUNCTIONS: DRAFT, POSITION, INTERMIX, FLOAT POSITION			●		●		●		●
ELECTRONICALLY-CONTROLLED HITCH			●		●		●		●
LIFT CAPACITY WITH 2 ASSISTOR RAMS	KG	5400		5400		5400	5400	5400	5400
MAX. OPERATING PRESSURE	BAR	200		200		200	200	200	200
HYDRAULIC PUMP FLOW (HITCH + STEERING)	L/MIN	66+38		66+38		66+38	—	—	—
CLOSED CENTRE SYSTEM PUMP FLOW (HITCH + STEERING)	L/MIN	110+38		110+38		110+38	110+38	110+38	110+38
CAT. 2 THREE-POINT LINKAGE			●		●		●		●
HYDRAULIC ADJUSTMENT OF TOP LINK AND RIGHT LIFTING ROD			○		○		○		○
REMOTE VALVES STANDARD / OPTIONAL			3 - 5		3 - 5		3 - 5		3 - 5
FRONT HITCH AND FRONT PTO (MAX. LIFT CAPACITY)	KG	2500		2500		2500	2500	2500	2500

	X6.420 XTRASHIFT		X6.430 XTRASHIFT		X6.440 XTRASHIFT		X6.420 VT-DRIVE	X6.430 VT-DRIVE	X6.440 VT-DRIVE
	STD	LS	STD	LS	STD	LS	LS	LS	LS
<b>CAB AND DRIVING POSITION</b>									
DELUXE CAB / RADIO ADAPTOR		●		●		●	●	●	●
MECHANICAL CAB SUSPENSION		○		○		○	○	○	○
HEATING / VENTILATION		●		●		●	●	●	●
AIR-CONDITIONING	○	●	○	●	○	●	●	●	●
CLIMATE CONTROL	○	●	○	●	○	●	○	○	○
AIR SUSPENSION SEAT	○	●	○	●	○	●	●	●	●
AIR SUSPENSION SEAT WITH ARMREST	—	—	—	—	—	—	●	●	●
RADIO / BLUETOOTH / MP3 READY	○	—	○	—	○	—	○	○	○
DIGITAL INSTRUMENT PANEL	●	—	●	—	●	—	●	●	●
12" DSM TOUCHSCREEN MONITOR	—	—	—	—	—	—	●	●	●
ISOBUS ADAPTOR	—	—	—	—	—	—	○	○	○
SATELLITE GUIDANCE KIT (8" MONITOR + ANTENNA)	—	—	—	—	—	—	○	○	○
BUDDY SEAT + REFRIGERATOR IN-CAB STORAGE COMPARTMENT	●	—	●	—	●	—	●	●	●
<b>DIMENSIONS AND WEIGHTS</b>									
FRONT TYRES		440/65R28		440/65R28		440/65R28	440/65R28	440/65R28	440/65R28
REAR TYRES		540/65R38		540/65R38		540/65R38	540/65R38	540/65R38	540/65R38
A LENGTH 4WD	MM	4400		4400		4400	4400	4400	4400
B MIN. WIDTH	MM	2056		2056		2056	2056	2056	2056
C WHEELBASE 4WD	MM	2540		2540		2540	2540	2540	2540
D HEIGHT OVER CAB	MM	2805		2805		2805	2805	2805	2805
E GROUND CLEARANCE	MM	420		420		420	420	420	420
WEIGHT IN RUNNING ORDER (WITHOUT BALLAST)	KG	4700		4700		4700	5200	5200	5200
WEIGHT IN RUNNING ORDER WITH HYDRAULIC SUSPENSIONS (WITHOUT BALLAST)	KG	5200		5200		5200	5800	5800	5800
<b>OPTIONAL EQUIPMENT</b>									
10 FRONT BALLAST WEIGHTS 42 KG EACH		○		○		○	○	○	○
300 KG FRONT WEIGHT FOR HITCH		○		○		○	○	○	○

Key: ● standard ○ option — not available LS\* Load Sensing

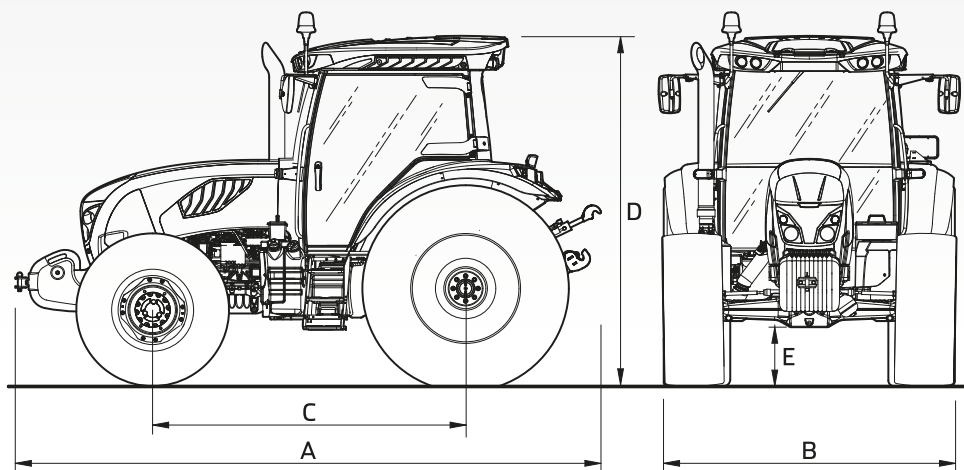





via G. Matteotti, 7 | 42042 Fabbrico [RE] Italia  
t. +39.0522.656.111 | f. +39.0522.656.476  
webmaster@argotracors.com | www.argotracors.com



graphic design: gruppo saldatori bzzbzz@grupposaldatori.com  
All data and illustrations provided in this brochure are for  
information purposes only and can be changed without notice.

 **6615865A2**