

gru_truck cranes

www.pesci-cranes.com



PESCI



SE 35

QUALITY

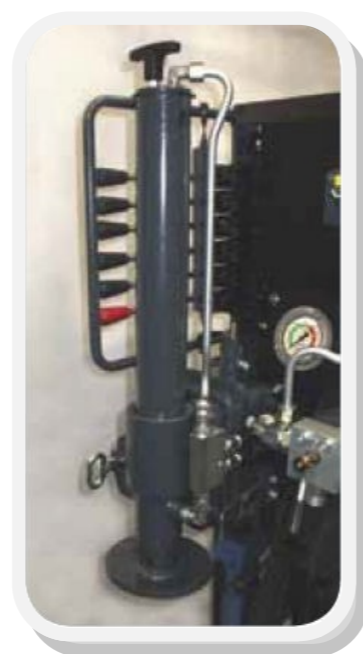

gru_truck cranes



power & technology

- ▶ Scheda tecnica
- ▶ Fiche technique
- ▶ Technische daten
- ▶ Technical features
- ▶ Ficha tecnica
- ▶ Folha de dados



V. EMILIA 281 _ 48014 CASTEL BOLOGNESE (RA) _ ITALY
Tel +39.0546.653.833 _ Fax +39.0546.656.205
e-mail: info@pesci-cranes.com _ www.pesci-cranes.com

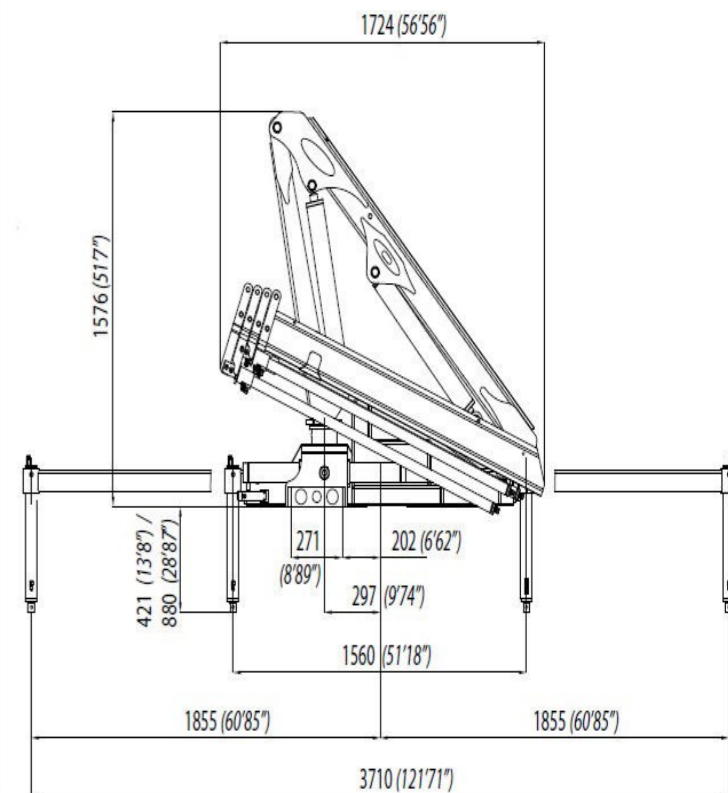
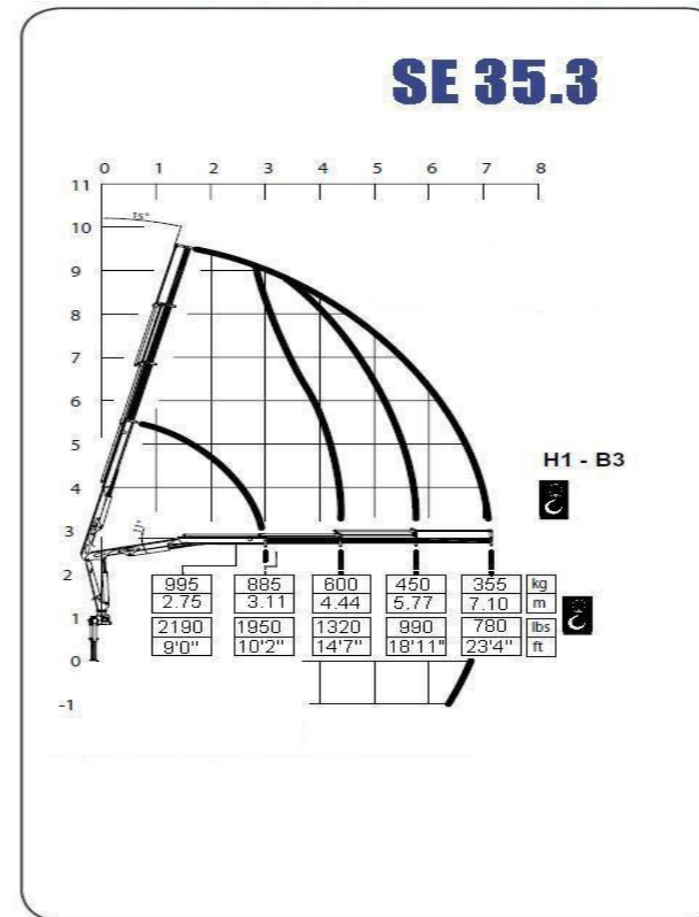
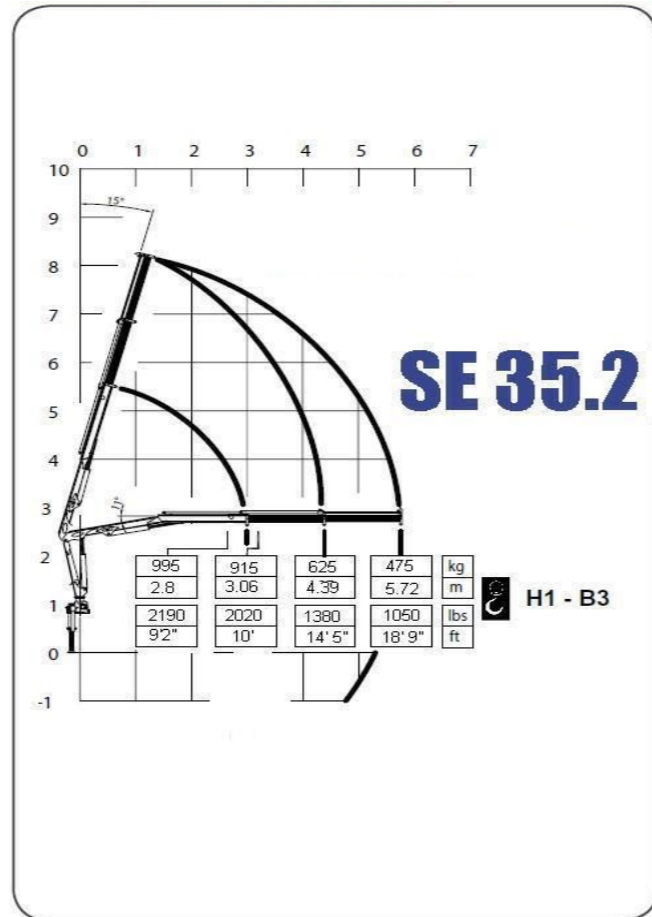
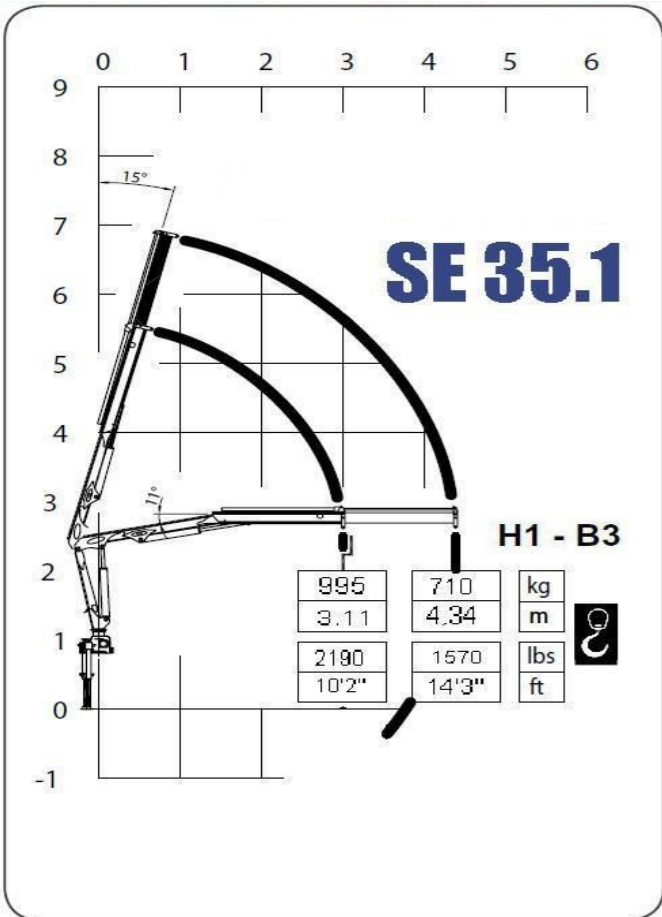

	1	2	3
- MOMENTO MAX SOLLEVAMENTO	30,36	27,47	27,00
- HUBMOMENT			
- COUPLE DE LEVAGE			
- MOMENTO	kN.m	kN.m	kN.m
- MOMENTO	21959	19869	19529
- MAX LIFTING MOMENT	lbs.ft	lbs.ft	lbs.ft

	1	2	3
- PORTATA POMPA OTTIMALE	10	10	10
- FÖRDERMENGE DER PUMPE			
- PORTÉE DE LA POMPE			
- CAUDAL DE LA BOMBA	l/min	l/min	l/min
- CAUDAL DA BOMBA	2,63	2,63	2,63
- RECOMMENDED PUMP DELIVERY	gal/min	gal/min	gal/min

	1	2	3
- ANGOLO DI ROTAZIONE	400°	400°	400°
- SCHWENKBEREICH			
- ROTATION			
- GIRO			
- ROTAÇÃO			
- SLEWING ANGLE			

	1	2	3
- CAPACITÀ SERBATOIO OLIO	30	30	30
- FASSUNGSVERMÖGEN DEL ÖLBEHALTERS			
- CAPACITÉ RÉSERVOIR HUILE			
- CAPACIDAD DEL DEPOSITO DE ACEITE	l	l	l
- CAPACIDAD DO DEPÓSITO DE OLEO	7,92	7,92	7,92
- OIL TANK CAPACITY	gal	gal	gal

	1	2	3
- COPPIA MAX ROTAZIONE	500	500	500
- MAX SCHWENKMOMENT			
- COUPLE MAXI. DE ROTATION			
- POTENCIA MÁXIMA DE GIRO	daNm	daNm	daNm
- BINARIO MÁXIMO DE ROTAÇÃO	3617	3617	3617
- SLEWING TORQUE	lbs.ft	lbs.ft	lbs.ft

	1	2	3
- VEICOLO MIN. P.T.T.	2,8	2,8	2,8
- LKW MIN. G.G.W.			
- CAMION MIN. P.T.A.C.			
- CAMION PESO MIN. P.T.T.	t	t	t
- P.B. MIN CAMION			
- TRUCK MIN. G.V.W.			

	1	2	3
- PRESSIONE MAX LAVORO	260	260	260
- DRUCK			
- PRESSION	bar	bar	bar
- PRESSIÓN			
- PRESSÃO	3770	3770	3770
- MAX WORKING PRESSURE	psi	psi	psi

	1	2	3
- PESO GRU	420	455	490
- GEWICHT			
- POIDS	Kg	Kg	Kg
- PESO			
- PESO	930	1000	1080
- CRANE WEIGHT	lbs	lbs	lbs

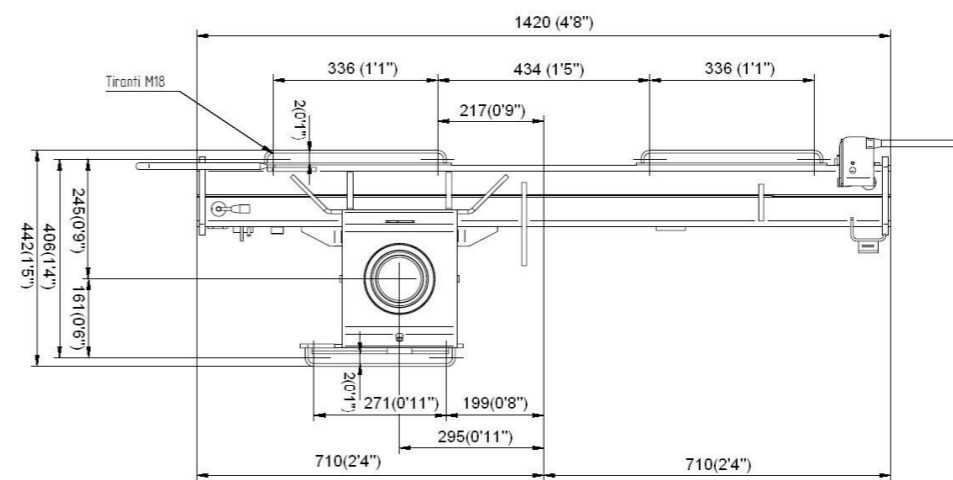

ROTAZIONE SLEWING ANGLE 400°

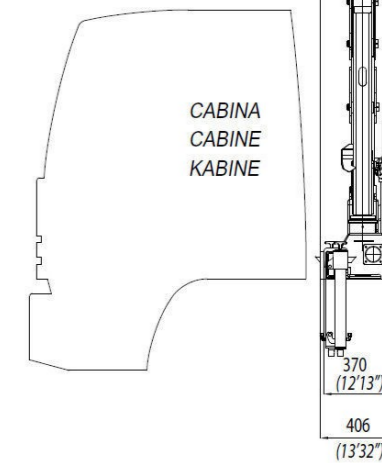
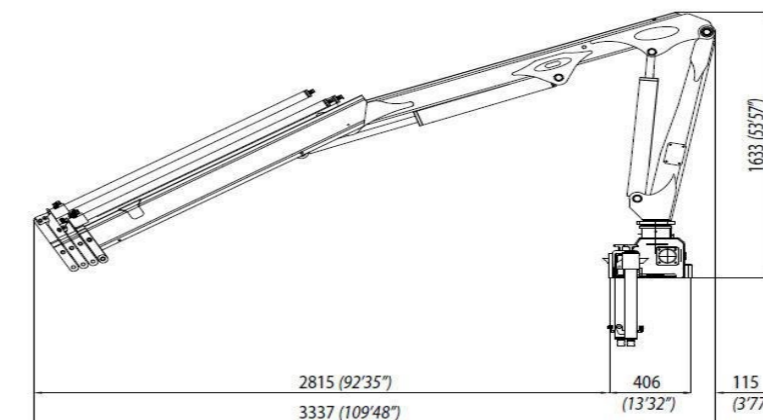

I dati e le descrizioni del presente catalogo sono forniti a titolo indicativo e non sono vincolanti. PESCI si riserva il diritto di modificarli senza preavviso. Technical features are not binding. PESCI reserves itself the right to any modification without notice.