



Product description

- Low feeding height
- Robust steel construction
- Hydraulic liftable screenbox
- Optimal transport dimensions
- Hydraulic folding hopper sides
- Hydraulic folding discharge belts

RSS514

Mobile track-mounted scalping screen RSS514

Page 01 of 05

Application areas

Designed for a variety of applications and highest throughput

The scalping screen RSS514 can be used to **separate demolition debris, asphalt, concrete, bricks, coal, metal, top soil, compost** and **virgin stone**.

Applications of the scalping screen:

- **as individual machine** to produce **3 final fractions**
- **as pre-screen** before the crusher for the production of **2 additional defined fractions**, the separation of fines serves as **wear protection** and **increases the crusher performance**
- **as final screening unit** after the crusher to separate the crusher product in **3 final fractions**

The machine is available either with a **belt feeder** or optionally with a **steel apron feeder**.

Features & benefits

- Short set-up time
- Easy handling
- Low feeding height
- Robust steel construction
- Folding hopper tailgate for direct crusher feeding
- Optimal transport dimensions
- Hydraulic raise screenbox to facilitate mesh change
- Hydraulic folding hopper sides as standard
- Hydraulic folding discharge belts
- Easy access to the engine compartment
- Screenbox walkways



KORMANN ROCKSTER RECYCLER GMBH

Wirtschaftszeile West 2 / 4482 Ennsdorf / AUSTRIA

Tel.: +43 7223 81000 / office@rockster.at / www.rockster.at

Main dimensions

Working position:

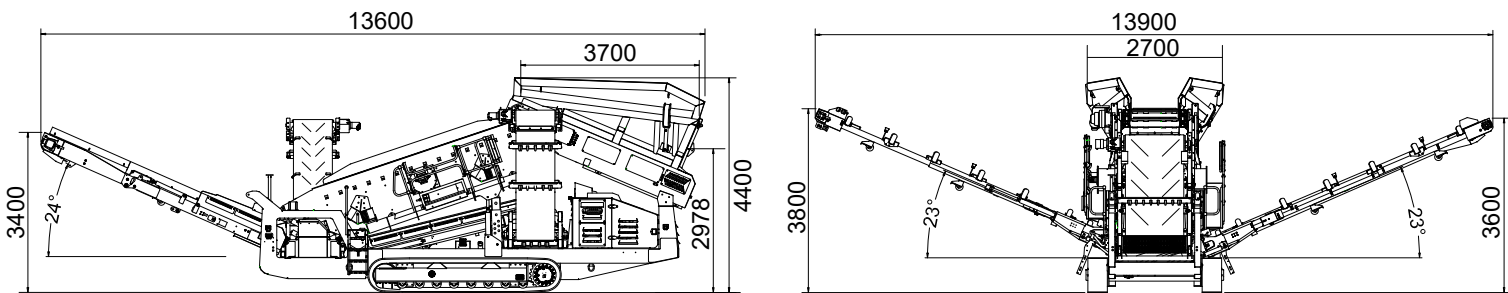

Transport position:

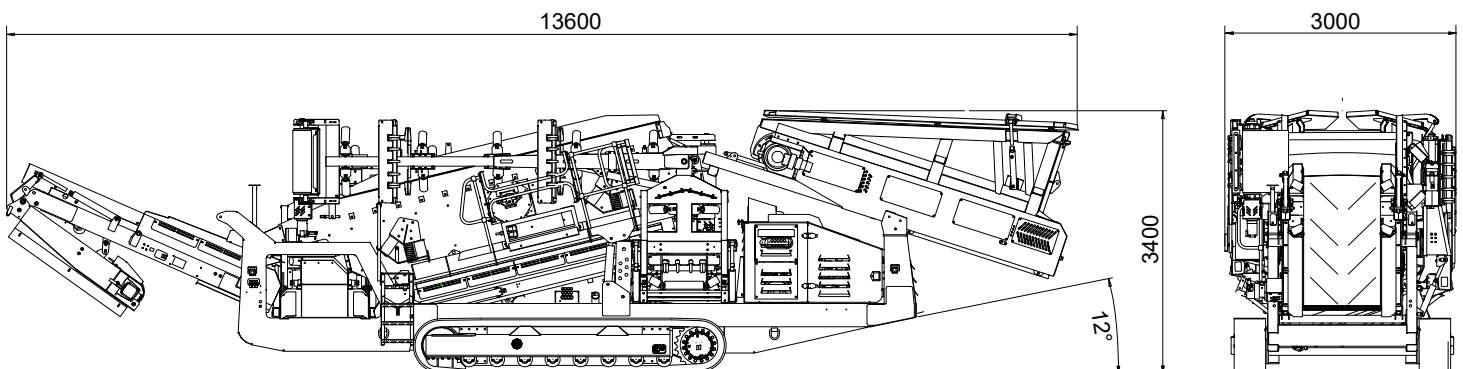

Dimensions in working position:

Length: 13,60 m | 44.6 ft
Width: 13,90 m | 45.6 ft
Height: 4,40 m | 14.4 ft

Transport dimensions:

Length: 13,60 m | 44.6 ft
Width: 3,00 m | 9.9 ft
Height: 3,40 m | 11.2 ft
Weight with belt feeder: ~ 23,0 t | 50,700 lbs
Weight with apron feeder: ~ 27,0 t | 59,500 lbs



Technical details

Performance:

Max. feed size: 500 mm | 20 in
Capacity: up to 375 t/h | 410 st/h

Feed hopper:

Width: 2,70 m | 8.9 ft
Length: 3,70 m | 12.1 ft
Max. volume: 7,20 m³ | 9.4 yd³

Screen surface (both decks):

Length: 4,30 m | 14.1 ft
Width: 1,52 m | 5.0 ft
Angle: 15 - 19°
Screen decks: acc. to customer requirements

Feeder belt:

Width: 1,20 m | 4.0 ft
Speed: variable

Right side fines belt:

Width: 0,80 m | 2.6 ft
Discharge height: ~ 3,80 m | 12.5 ft
Speed: variable

Left side mids belt:

Width: 0,80 m | 2.6 ft
Discharge height: ~ 3,60 m | 11.8 ft
Speed: variable

Oversize belt:

Width: 1,20 m | 4.0 ft
Discharge height: ~ 3,40 m | 11.2 ft
Speed: variable

Collection belt:

Width: 1,20 m | 4.0 ft
Speed: constant

Drive unit:

CAT 4.4 75kW | 102 hp, stage 3a or
CAT 4.4 (T4i) 75 kW | 102 hp, stage 3b
Diesel tank: 390 | 85 gallon/103 US gallon
Hydraulic tank: 450 | 98 gallon/118 US gallon

Tracks:

Width: 400 mm | 16 in
Speed: 1 km/h | 0.62 mph

Apron feeder:

Width: 1,20 m | 4.0 ft
Speed: variable

Options

- Top deck:
Mesh, bofor bar,
finger tines, punch plate
- Radio remote control
- JCB engine 444 DieselMax stage 3a,
85 kW | 116 hp
- JCB engine 444 EcoMax stage 3b,
93 kW | 126 hp
- Apron feeder



RSS514

Mobile track-mounted scalping screen RSS514

ROCKSTER
RECYCLER

Page 04 of 05



KORMANN ROCKSTER RECYCLER GMBH

Wirtschaftszeile West 2 / 4482 Ennsdorf / AUSTRIA

Tel.: +43 7223 81000 / office@rockster.at / www.rockster.at



General information

Page 05 of 05

The company **Kormann Rockster Recycler GmbH** specializes in the development and production of mobile crushing and screening systems. The Rockster-team consists exclusively of long-time market insiders, each bringing **years of experience** into perfecting the Rockster design concept, as well as being personally available to share their expertise with customers.

Customer orientation and maximum customer care is the ultimate ambition of all Rockster products and services. The key criteria specified by Rockster are **maximum performance** and **quality**, operating and maintenance friendliness as well as easy transportation due to **compact dimensions** and low weight.

The ROCKSTER concept

RELIABILITY

Maximum reliability due to the highest product quality standards.

OPERATING EFFICIENCY

Higher operational efficiency due to the transport dimensions (easy transport – no special permits in many cases), simple maintenance and handling.

CAPACITY

Higher production capacity as a result of special high-speed rotor and enormous power reserves for the drive systems.

KNOWLEDGE

Many years of practical experience in advanced machine design creates tremendous value for customers.

SERVICE

Round-the-clock service and support is the company hallmark, with rapid response and immediate availability of spare and wear parts.

TECHNOLOGY

Using industry-standard brand components assures adherence to the highest technical standard.

ENVIRONMENT FRIENDLY

Engineered to meet the highest environmental standards with the installation of low-pollution engines and complex sound suppression systems.

REVENUE

Designed to meet customers' revenue and return-on-investment requirements due to low investment and operating costs, plus the unique advantages of the DUPLEX system – maximizing machine utilization with multiple crusher capabilities on one carrier.



KORMANN ROCKSTER RECYCLER GMBH

Wirtschaftszeile West 2 / 4482 Ennsdorf / AUSTRIA

Tel.: +43 7223 81000 / office@rockster.at / www.rockster.at