

MOVING YOU FURTHER

Robex
170w-9

With Tier 3 Engine installed



*Photo may include optional equipment.

 **HYUNDAI**
CONSTRUCTION EQUIPMENT

Head Office (Sales office)

First tower, 55, Bundang-ro, Bundang-gu, Seongnam-si, Gyeonggi-do, Korea

PLEASE CONTACT

www.hyundai-ce.com

2019. 11 Rev.6

 **HYUNDAI**
CONSTRUCTION EQUIPMENT

Pride at Work

Hyundai Construction Equipment strives to build state-of-the-art earthmoving equipment to give every operator maximum performance, more precision, versatile machine preferences, and proven quality. Take pride in your work with Hyundai!



Robex 170w-9

Machine Walk-Around

Engine Technology

Proven and reliable, fuel efficient HYUNDAI HE6.7 engine
Electronically controlled for optimum fuel-to-air ratio and clean, efficient combustion
Low noise / Auto engine warm up feature / Anti-restart feature

Hydraulic System Improvements

New patented hydraulic control system for improved controllability / Improved control valve design for added efficiency and smoother operation / New auto boom and swing priority system for optimum speed / New auto power boost feature for additional power when needed / Improved arm-in flow regeneration system for added speed and efficiency

Pump Compartment

Industry-leading, powerful, reliable Kawasaki designed, variable volume tandem axial piston pumps
New compact solenoid block equipped with 4 solenoid valves, 1 EPPR valve, 1 check valve, accumulator and pilot filter - controls, power boost, boom priority, safety lock, arm-in regeneration control, creep, swing logic valve control
Remotely mounted fuel, engine oil and case drain filters for maximum convenience while servicing

Improved Steering Column

Slim-profile steering column capable of telescoping 60 mm and tilting 30 degrees

Carrier

Heavy duty carrier frame with two speed powershift transmission
Heavy duty drive line and axles
Front axle oscillation +/- 7 degrees with ram lock
Wet disc brake with no digging effect (front & rear)
Automatic parking brake - spring applied, hydraulically released

Enhanced Operator Cab

Improved visibility

Enlarged cab with improved visibility / See-through upper skylight for visibility and ventilation
Larger right-side glass, now one piece, for better right visibility
Safety glass windows on all sides - less expensive than (polycarbonate) and won't scratch or fade
Closeable sunshade for operator convenience / Reduced front window seam for improved operator view

Improved Cab Construction

New steel tube construction for added operator safety, protection and durability
New window open/close mechanism designed with cable and spring lift assist and single latch release

Improved Suspension Seat / Console Assembly

Ergonomic joysticks with auxiliary control buttons for attachment use. Now with new sleek styling
Heated suspension (standard) or optional air ride suspension with heat
New joystick consoles - now adjustable in height by way of dial at bottom
Adjustable arm rests - turn dial to raise or lower for optimum comfort

Advanced 7" Color Cluster

New color LCD display with easy-to-read digital gauges for hydraulic oil temperature, water temperature, and fuel
Simplified design makes adjustment and diagnostics easier. Also, new enhanced features such as rear-view camera are integrated into monitor.

3 power modes : (P) Power, (S) Standard, (E) Economy, 2 work modes : Dig & Attachment, (U) User mode for operator preference
Enhanced self-diagnostic features with GPS download capability

One pump flow or two pump flow for optional attachment now selectable through the cluster / New anti-theft system with password capability

Boom speed and arm regeneration are selectable through the monitor.

Auto power boost is now available - selectable (on/off) through the monitor.

Powerful air conditioning and heat with auto climate control, 20% more heat and air output than 7A series!

Hi-MATE (Remote Management System) works through GPS/Satellite technology to ultimately provide better customer service and support.

Preference

Operating a 9 Series is unique to every operator. Operators can fully customize their work environment and operating preferences to fit their individual needs.



*Photo may include optional equipment.



Wide Cabin with Excellent Visibility

The newly designed cabin was conceived for more space, a wider field of view and operator comfort. Special attention was given to a clear, open and convenient interior with plenty of visibility on the machine surroundings and the job at hand. This well balanced combination of precision aspects put the operator in the perfect position to work safely and securely.

Operator Comfort

In a 9 series cabin you can easily adjust the seat, console and armrest settings to best suit your preferred comfort level. Seat and console position and height can be set together and independent from each other. Improved steering wheel telescope and tilt functions provide operators improved access. A fully automatic, high capacity airconditioning system maintains a constant preferred temperature. During cold weather conditions, the PTC cab heater provides immediate heat at startup for added operator comfort.



Reduced Stress

Work is stressful enough. Your work environment should be stress free. Hyundai's 9 series provides improved cab amenities, additional space and a comfortable seat to minimize stress to the operator. A powerful climate control system provides the operator with optimum air temperature. An advanced audio system with USB player, AM/FM stereo and MP3 capabilities, plus remotely located controls is perfect for listening to music favorites. Operators can even talk on the phone with the hands-free cell phone feature.



Operator - Friendly Cluster

The advanced new cluster with 7 inch wide color LCD screen and toggle switch allows the operator to select his personal machine preferences. Power and work mode selection, self diagnostics, rear-view camera, maintenance check lists, start-up machine security, and video functions were integrated into the cluster to make the machine more versatile and the operator more productive.



Precision

Innovative hydraulic system technologies make the 9 Series excavator fast, smooth and easy to control.



*Photo may include optional equipment.

Computer Aided Power

The engine horsepower and hydraulic horsepower work together in unison through the advanced CAPO(Computer Aided Power Optimization) system.

This system interfaces with multiple sensors placed throughout the hydraulic system, as well as the electronically controlled engine, to provide the optimum level of engine power and hydraulic flow for the job at hand.

Operators can set their own preferences for boom or swing priority, power mode selection and optional work tools at the touch of a button. The CAPO system also provides complete self diagnostic features and digital gauges for important information like hydraulic oil temperature, water temperature and fuel level.

Three unique power modes provide the operator with custom power, speed and fuel economy.

Power Mode
P (Power Max) mode maximizes machine speed and power for mass production.
S (Standard) mode provides a reduced, fixed rpm for optimum performance and improved fuel economy. For maximum fuel savings and improved control, E (Economy) mode provides precise flow and engine power based on load demand.

Work Mode
The work mode allows the operator to select single flow attachments like a hydraulic breaker or bi-directional flow attachments like a crusher. Flow settings unique to each attachment can be programmed from within the cluster.

User Mode
Some jobs require more precise machine settings. Using the versatile U (User) mode, the operator can customize engine speed, pump output, idle speed and other machine settings according to personal preferences.

Improved Hydraulic System



To achieve optimum precision, Hyundai redesigned the hydraulic system to provide the operator with super fine touch and improved controllability. Improved pump flow control reduces flow when controls are not being used to minimize fuel consumption.

Improved spool valves in the control valve are engineered to provide more precise flow to each function with less effort.

Improved hydraulic valves, precision-designed variable volume piston pumps, fine-touch pilot controls, and enhanced travel functions make any operator running a 9

series look like a smooth operator. Newly improved features include arm-in and boom-down flow regeneration, improved control valve technology and innovative auto boom and swing priority for optimal performance in any application.



Auto Boom-swing Priority

This smart function automatically and continuously looks for the ideal hydraulic flow balance for the boom and swing functions of the machine. The advanced CAPO system monitors the hydraulic system and adjusts its settings to maximize performance and productivity.

Performance

9 Series is designed for maximum performance to keep the operator working productively.

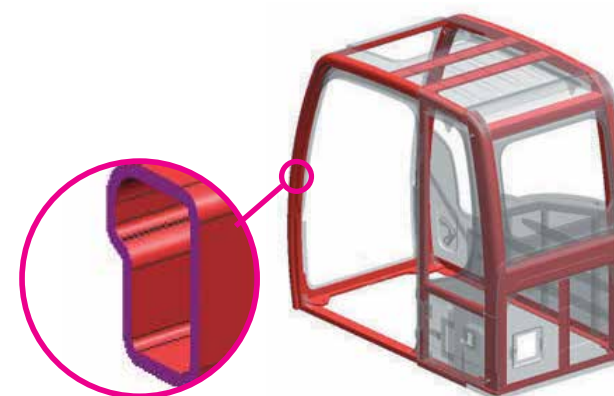

*Photo may include optional equipment.



Fully Independent Outrigger System

R170W-9 can be equipped with four independent outriggers (front and rear) or two independent outriggers and a dozer blade (front or rear). Each outrigger and the dozer blade are controlled by a switch and the dozer lever. Each outrigger is equipped with cylinder guards for added protection.



Structural Strength

The 9 series cabin structure has been fitted with stronger but slimmer tubing for more safety and better visibility. Low-stress and high strength steel was integrally welded to form a strong and stable lower frame. Structural durability was evaluated and tested by means of FEM (Finite Elements Method) analysis and long-term durability tests.

New and Improved Travel System

Auto cruise control system reduces operator fatigue by maintaining a fixed speed when driving distances. A new auto ram lock system is available to improve operating safety. A new creep speed travel system improves maneuverability and fine control. A new optional forward / reverse travel pedal control allows operators to choose to use the travel pedal control while in work mode or lever control when in travel mode.



Auto cruise control system Auto ram lock system Creep speed travel system



HYUNDAI HE 6.7 ENGINE

The Tier III, six cylinder, 4 cycle, turbo-charged, charge air cooled, HYUNDAI HE 6.7 engine provides maximum power, reliability, optimum fuel economy, and reduced emissions. Electronically controlled fuel injection and diagnostic capabilities add to the engine's efficiency and serviceability.

Profitability

9 Series is designed to maximize profitability through improved efficiencies, enhanced service features and longer life components.



*Photo may include optional equipment.



Fuel Efficiency

9 series excavators are engineered to be extremely fuel efficient. New innovations like the variable speed fan clutch, overload prevention control, two-stage auto decel system, and the new economy mode, conserve fuel and reduce the impact on the environment.



Hi-MATE (Remote Management System)

Hi-MATE, Hyundai's proprietary remote management system, provides operators and dealer service personnel access to vital service and diagnostic information on the machine from any computer with internet access. Users can pinpoint machine location using digital mapping and set machine work boundaries, reducing the need for multiple service calls. Hi-MATE saves time and money for the owner and dealer by promoting preventative maintenance and reducing machine downtime.



Easy Access

Ground-line access to filters, lube fittings, fuses, machine computer components and wide open compartments makes service more convenient on the 9S Series.



Long-Life Components

9 series excavators were designed with bushings designed for long-life lube intervals (250 hrs) & polymer shims (wear resistant, noise reducing), long-life hydraulic filters (1,000hrs), long-life hydraulic oil (5,000hrs), more efficient cooling systems and integrated preheating systems which extend service intervals, minimize operating costs and reduce machine down time.

Specifications

ENGINE

MODEL	HYUNDAI HE6.7		
Type	Water-cooled, 4-cycle diesel, 6-cylinder in-line, Direct injection, Turbocharged, Charge air cooled, Low emission		
Rated flywheel horsepower	SAE	J1995 (gross)	163 HP (122kW) at 2,100 rpm
		J1349 (net)	153 HP (114kW) at 2,100 rpm
	DIN	6271/1 (gross)	165 PS (122kW) at 2,100 rpm
		6271/1 (net)	155 PS (114kW) at 2,100 rpm
Max. torque	74.7 kgf-m(540 lbf-ft) at 1,400 rpm		
Bore X stroke	107 x 124 mm (4.21" x 4.88")		
Piston displacement	6,700 cc (409 in ³)		
Batteries	2 x 12 V x 100 AH		
Starting motor	24V-4.5kW		
Alternator	24V-70 Amp		

HYDRAULIC SYSTEM

MAIN PUMP	
Type	Two variable displacement piston pumps
Rated flow	2 X 168 L /min (44.4 US gpm/37 UK gpm)
Sub-pump for pilot circuit	Gear pump

Cross-sensing and fuel saving pump system

HYDRAULIC MOTORS	
Travel	Two-speed axial pistons motor with brake valve and parking brake
Swing	Axial piston motor with automatic brake

RELIEF VALVE SETTING	
Implement circuits	350 kgf/cm ² (4,970 psi)
Travel	380 kgf/cm ² (5,400 psi)
Power boost (boom, arm, bucket)	380 kgf/cm ² (5,400 psi)
Swing circuit	285 kgf/cm ² (4,050 psi)
Pilot circuit	40 kgf/cm ² (570 psi)
Service valve	installed

HYDRAULIC CYLINDERS	
No. of cylinder bore X stroke	Boom : 2-115 x 1090 mm (4.5" x 42.9")
	Arm : 1-120 x 1355 mm (4.7" x 53.3")
	Bucket : 1-110 x 995 mm (4.3" x 39.2")
	Blade : 2-110 x 235 mm (4.3" x 9.3")
	Outrigger : 2-125 x 463 mm (4.9" x 18.2")
	2-PCS boom : 2-115 x 960 mm (4.1" x 37.8")
	Adjust(boom) : 1-160 x 650 mm (6.3" x 25.6")

DRIVES & BRAKES

4-wheel hydrostatic drive. Constant mesh, helical gear transmission provides 2 forward and reverse travel speeds.

Max. drawbar pull	11,000 kgf (24,250 lbf)	
Travel speed	1st	10 km/h
	2nd	36 km/h
Gradeability	35°(70 %)	

Service Brake :
 - Independent dual brake, front and rear axle full hydraulic power brake.
 - Spring released and hydraulic applied wet type multiple disc brake.
 Parking Brake :
 - Spring applied and hydraulic released wet disc brake type in transmission.

CONTROL

Pilot pressure operated joysticks and pedals with detachable lever provide almost effortless and fatigueless operation.

Pilot control	Two joysticks with one safety lever (LH): Swing and arm, (RH): Boom and bucket (ISO)
Engine throttle	Electric, Dial type

AXLE & WHEEL

Full floating front axle is supported by center pin for ocillation. It can be locked by ocillation lock cylinders. Rear axle is fixed on the lower chassis.

Tires	10.00-20-14PR, Dual(tube type)
(optional)	10.00-20, Dual(solid type)

SWING SYSTEM

Swing motor	Fixed displacement axial pistons motor
Swing reduction	Planetary gear reduction
Swing bearing lubrication	Grease-bathed
Swing brake (option)	Multi wet disc (pin lock type)
Swing speed	11 rpm

STEERING SYSTEM

Hydraulically actuated, orbitrol type steering system actuates on front wheels through the steering cylinders.

Min. turning radius	6,300 mm (20' 8")
---------------------	-------------------

COOLANT & LUBRICANT CAPACITY

Refilling	liter	US gal	UK gal	
Fuel tank	270	71.3	59.4	
Engine coolant	19.5	5.2	4.3	
Engine oil	24	6.3	5.3	
Swing device - gear oil	5	1.3	1.1	
Axle	Front	15.5	4.1	3.4
	Rear	17.5	4.6	3.9
Hydraulic system (including tank)	270	71.3	59.4	
Hydraulic tank	160	42.3	35.2	

UNDERCARRIAGE

Reinforced box-section frame is all-welded, low-stress. Dozer blade and outriggers are available. A pin-on design.

Dozer blade	A very useful addition for leveling and back filling or clean-up work.
Outrigger	Indicated for max. operation stability when digging and lifting. Can be mounted on the front/or the rear.

OPERATING WEIGHT (APPROXIMATE)

Operating weight, including 5,100mm (16' 9") Mono boom, 2,200mm (7' 3") arm, SAE heaped 0.76m³ (0.99yd³) backhoe bucket, lubricant, coolant, full fuel tank, hydraulic tank and the standard equipment.

MAJOR COMPONENT WEIGHT	
Upperstructure	4,590kg (10,120 lb)
Mono boom(with arm cylinder)	1,240kg (2,730 lb)
Hydraulic adjustable boom (with adjust cylinder and arm cylinder)	1,780kg (3,920 lb)

OPERATING WEIGHT		
Undercarriage	Mono boom	Hyd. adjustable boom
Rear dozer blade	17,300 (38,140)	17,770 (39,180)
Rear outrigger	17,450 (38,470)	17,920 (39,510)
Front outrigger and rear blade	18,420 (40,610)	18,890 (41,650)
Front blade and rear outrigger	18,360 (40,480)	18,830 (41,510)
Four outrigger	18,600 (41,010)	19,070 (42,040)

AIR CONDITIONING SYSTEM

The air condition system for the machine contains the fluorinated greenhouse gas with global warming potential of R134a. (Global Warming Potential : 1430)

The system hold 0.75kg refrigerant consisting of a CO₂ equivalent 1.07kg metric tonne. For more information, Please refer to the manual.

BUCKETS

All buckets are welded with high-strength steel.

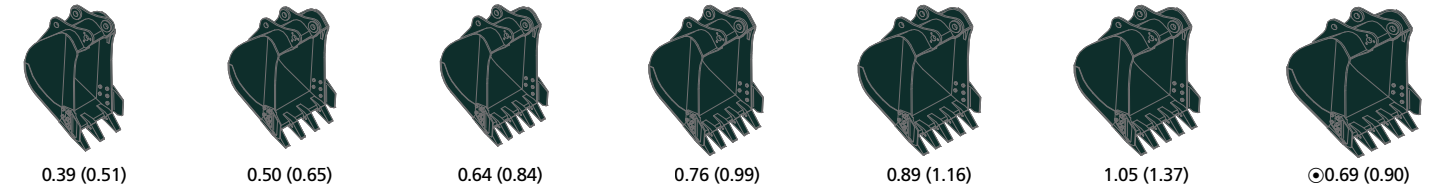

SAE heaped m³ (yd³)

Capacity m ³ (yd ³)		Width mm (in)		Weight kg (lb)	Recommendation mm (ft-in)				
SAE heaped	CECE heaped	Without sidecutters	With sidecutters		5,100 (16' 9") Mono Boom			5,100 (16' 1") Hydraulic Adjustable Boom	
					2,200 (7' 3") Arm	2,600 (8' 6") Arm	3,100 (10' 2") Arm	2,200 (7' 3") Arm	2,600 (8' 6") Arm
0.39 (0.51)	0.34(0.44)	620(24.4)	740(29.1)	410(900)	●	●	●	●	●
0.50 (0.65)	0.44(0.58)	760(29.9)	880(34.6)	470(1040)	●	●	■	●	●
0.64 (0.84)	0.55(0.72)	920(36.2)	1,040(40.9)	510(1120)	●	●	■	●	■
0.76 (0.99)	0.65(0.85)	1,060(41.7)	1,180(46.5)	570(1260)	●	■	■	●	■
0.89 (1.16)	0.77(1.01)	1,220(48.0)	1,340(52.8)	610(1340)	■	▲	-	■	▲
1.05 (1.37)	0.90(1.18)	1,400(55.1)	1,520(59.8)	680(1500)	▲	-	-	▲	-
○ 0.69 (0.90)	0.62(0.81)	990(39.0)	-	700(1540)	●	▲	▲	■	▲

○ Heavy duty bucket

●: Applicable for materials with density of 2,000 kg /m³ (3,370 lb/ yd³) or less
 ■: Applicable for materials with density of 1,600 kg /m³ (2,700 lb/ yd³) or less
 ▲: Applicable for materials with density of 1,100 kg /m³ (1,850 lb/ yd³) or less

ATTACHMENT

Booms and arms are welded with a low-stress, full-box section design. 5.1m (16' 9") boom, 5.1m (16' 1") Hydraulic Adjustable Boom and 2.2m (7' 3"), 2.6m (8' 6"), 3.1m (10' 2") arms.

DIGGING FORCE

Boom	Length	mm (ft-in)	5,100 (16' 9")			Remarks
	Weight	kg (lb)	1,240 (2,730)			
Arm	Length	mm (ft-in)	2,200 (7' 3")	2,600 (8' 6")	3,100 (10' 2")	Remarks
	Weight	kg (lb)	750 (1,560)	810 (1,790)	890 (1,960)	
Bucket digging force	SAE	kN	107.9 [117.2]	107.9 [117.2]	107.9 [117.2]	[]: Power Boost
		kgf	11,000 [11,940]	11,000 [11,940]	11,000 [11,940]	
		lbf	24,250 [26,330]	24,250 [26,330]	24,250 [26,330]	
	ISO	kN	123.6 [134.2]	123.6 [134.2]	123.6 [134.2]	
		kgf	12,600 [13,680]	12,600 [13,680]	12,600 [13,680]	
		lbf	27,780 [30,160]	27,780 [30,160]	27,780 [30,160]	
Arm crowd force	SAE	kN	87.2 [94.7]	77.3 [83.9]	69.0 [74.9]	
		kgf	8,890 [9,650]	7,880 [8,560]	7,030 [7,630]	
		lbf	19,600 [21,280]	17,270 [18,860]	15,500 [16,830]	
	ISO	kN	91.0 [98.8]	80.3 [87.2]	71.4 [77.5]	
		kgf	9,280 [10,080]	8,190 [8,890]	7,280 [7,900]	
		lbf	20,460 [22,210]	18,060 [19,600]	16,050 [17,430]	

Note: Boom weight includes arm cylinder, piping, and pin
 Arm weight includes bucket cylinder, linkage, and pin

Dimensions & Working Range

R170W-9 DIMENSIONS

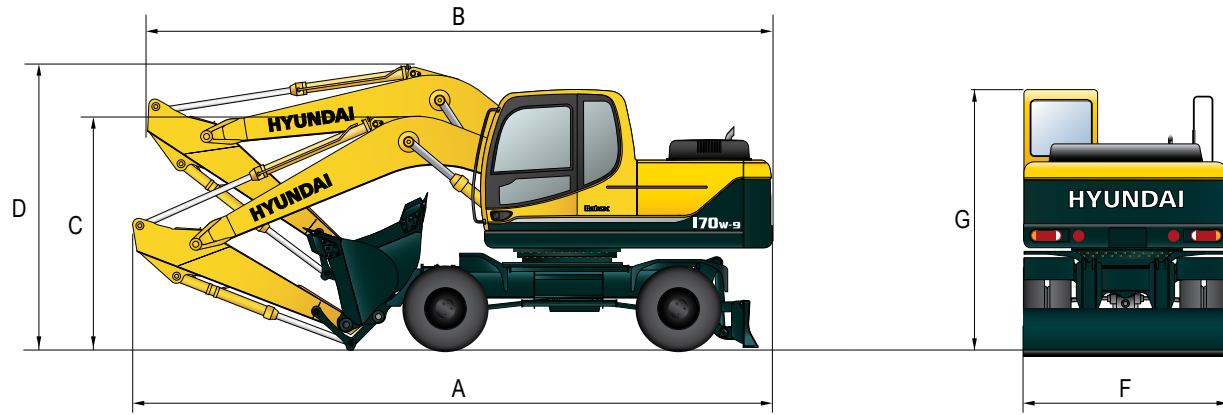

Unit : mm (ft-in)

	5,100 (16' 9")		
Mono Boom			
Arm	2,200 (7' 3")	2,600 (8' 6")	3,100 (11' 1")
A Overall length of shipping position	8,650 (28' 5")	8,730 (28' 8")	8,760 (28' 9")
B Overall length of traveling position	8,590 (28' 2")	8,400 (27' 7")	8,480 (27' 10")
C Height of attachment(shipping position)	3,060 (10' 0")	3,020 (9' 11")	3,150 (10' 4")
D Height of attachment(traveling position)	3,610 (11' 10")	3,940 (12' 11")	3,900 (12' 10")
F Overall width	2,500 (8' 2")	2,500 (8' 2")	2,500 (8' 2")
G Height of cabin	3,190 (10' 6")	3,190 (10' 6")	3,190 (10' 6")

R170W-9 WORKING RANGE

Unit : mm (ft-in)

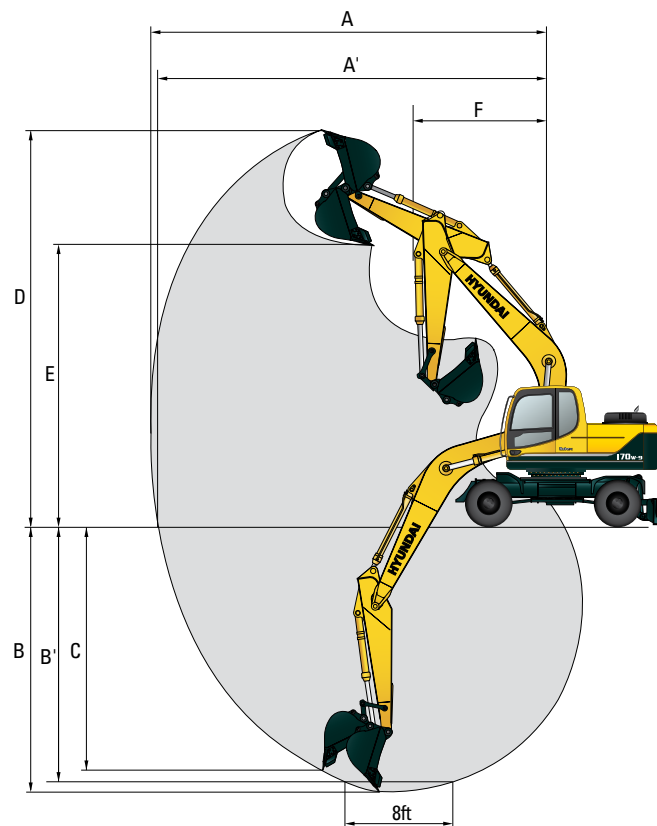

	5,100 (16' 9")		
Boom length			
Arm length	2,200 (7' 3")	2,600 (8' 6")	3,100 (10' 2")
A Max. digging reach	8,690 (28' 6")	9,020 (29' 7")	9,450 (31' 0")
A' Max. digging reach on ground	8,480 (27' 10")	8,810 (28' 11")	9,250 (30' 4")
B Max. digging depth	5,420 (17' 9")	5,820 (19' 1")	6,320 (20' 9")
B' Max. digging depth (8' level)	5,200 (17' 1")	5,620 (18' 5")	6,130 (20' 1")
C Max. vertical wall digging depth	4,890 (16' 1")	5,140 (16' 10")	5,470 (17' 11")
D Max. digging height	8,990 (29' 6")	9,070 (29' 9")	9,220 (30' 3")
E Max. dumping height	6,350 (20' 10")	6,460 (21' 2")	6,620 (21' 9")
F Min. swing radius	3,180 (10' 5")	3,170 (10' 5")	3,160 (10' 4")

R170W-9 ADJUSTABLE BOOM

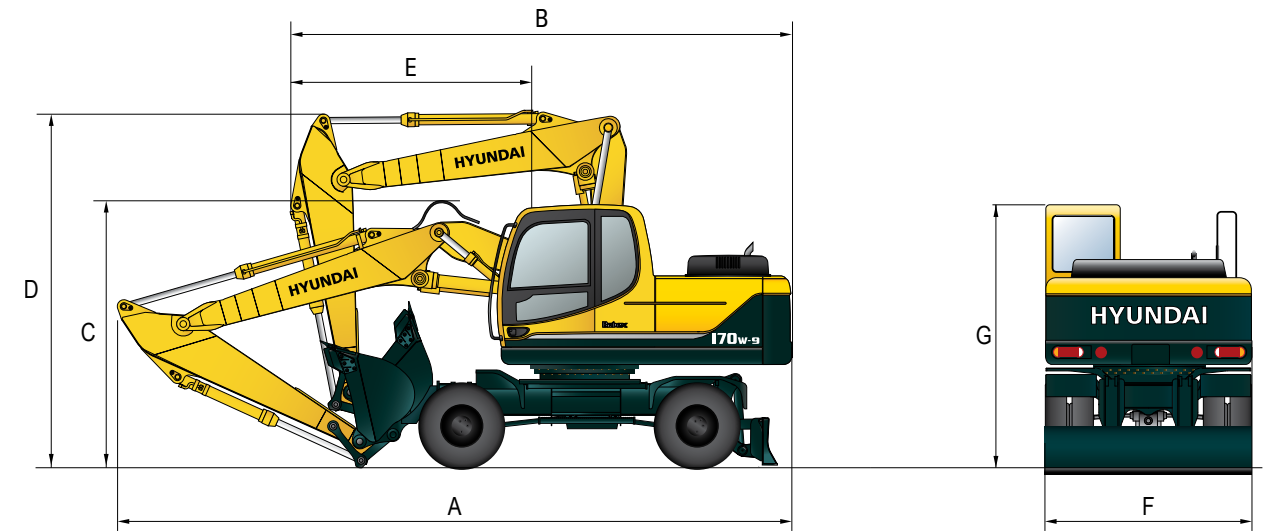

Unit : mm (ft-in)

	5,100 (16' 9")	
Hydraulic adjustable Boom		
Arm	2,200 (7' 3")	2,600 (8' 6")
A Overall length of shipping position	8,650 (28' 5")	8,750 (28' 8")
B Overall length of traveling position	6,630 (21' 9")	6,620 (21' 9")
C Height of attachment(shipping position)	2,900 (9' 6")	2,920 (9' 7")
D Height of attachment(traveling position)	3,980 (13' 1")	3,960 (13' 0")
E End of attachment to steering wheel	3,300 (10' 10")	3,290 (10' 10")
F Overall width	2,500 (8' 2")	2,500 (8' 2")
G Height of cabin	3,190 (10' 6")	3,190 (10' 6")

R170W-9 ADJUSTABLE BOOM WORKING RANGE

Unit : mm (ft-in)

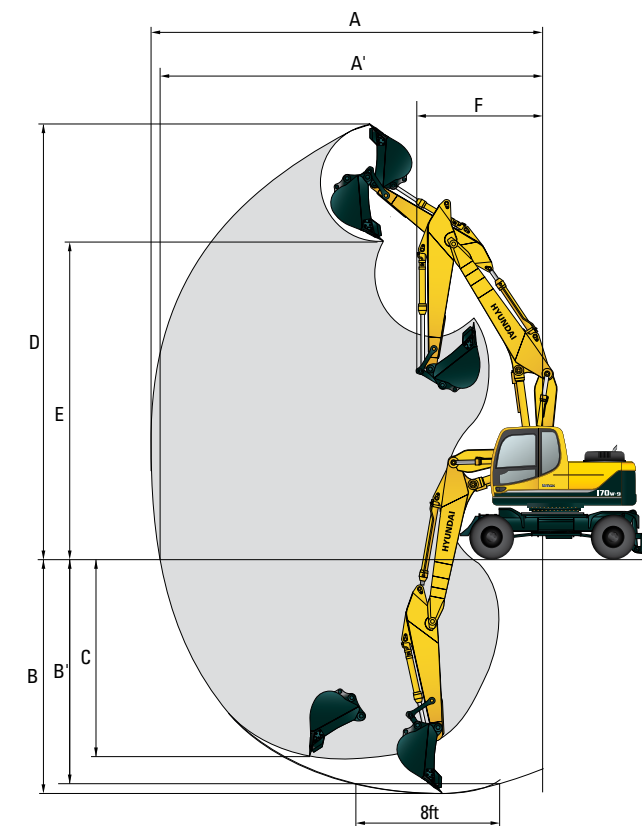

	5,100 (16' 9")	
Boom length		
Arm length	2,200 (7' 3")	2,600 (8' 6")
A Max. digging reach	8,760 (28' 9")	9,110 (29' 11")
A' Max. digging reach on ground	8,550 (28' 1")	8,910 (29' 3")
B Max. digging depth	5,220 (17' 2")	5,620 (18' 5")
B' Max. digging depth (8' level)	5,120 (16' 10")	5,520 (18' 1")
C Max. vertical wall digging depth	4,430 (14' 6")	4,780 (15' 8")
D Max. digging height	9,630 (31' 7")	9,820 (32' 3")
E Max. dumping height	6,930 (22' 9")	7,130 (23' 5")
F Min. swing radius	3,100 (10' 2")	2,970 (9' 9")

Undercarriage

R170W-9 WITH REAR DOZER AND FRONT REST

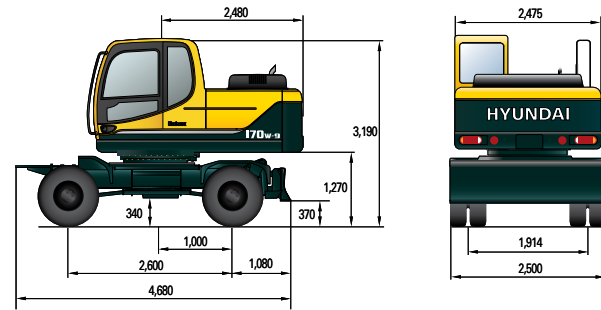

R170W-9 WITH REAR OUTRIGGER AND FRONT REST

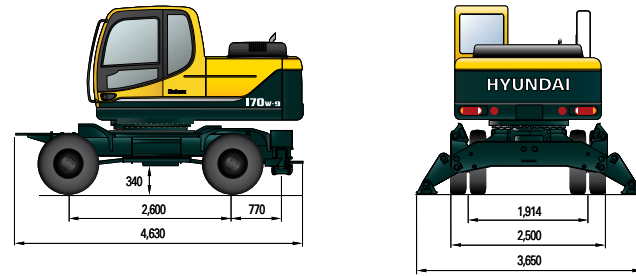

R170W-9 WITH REAR DOZER AND FRONT OUTRIGGER

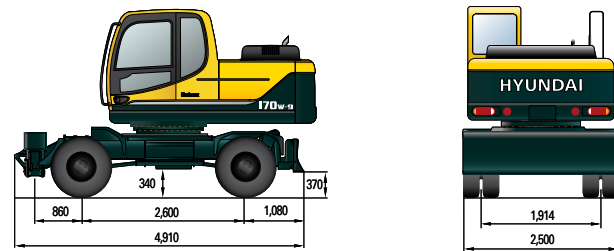

R170W-9 WITH REAR AND FRONT OUTRIGGER

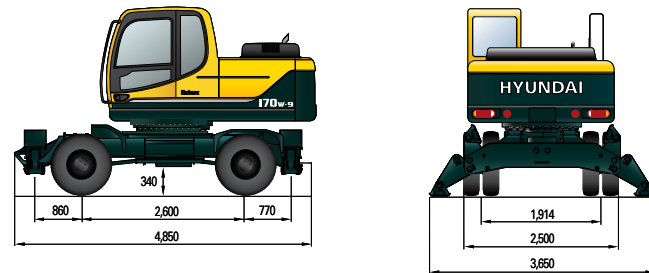

R170W-9 WITH REAR OUTRIGGER AND FRONT DOZER

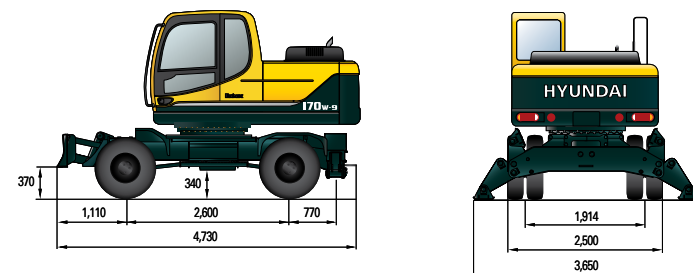

Lifting Capacity

R170W-9 MONO BOOM

Rating over-front Rating over-side or 360 degree

Boom : 5.1 m (16' 9") / Arm : 2.2 m (7' 3") / Bucket : 0.76 m³ (0.99 yd³) SAE heaped / With rear dozer blade down

Load point height m (ft)	Load radius								At max. reach		
	1.5 m (5 ft)		3.0 m (10 ft)		4.5 m (15 ft)		6.0 m (20 ft)		Capacity	Reach	
7.5 m (25 ft)									*3710	3020	5.89
6.0 m (20 ft)							*3340	2830	*3660	2080	7.15
4.5 m (15 ft)					*4730	4550	*4170	2770	*3690	1680	7.86
3.0 m (10 ft)			*9740	7880	*6000	4190	*4690	2630	3430	1500	8.19
1.5 m (5 ft)			*21470	17370	*13230	9240	*10340	5800	7560	3310	(26.9)
Ground					*7180	3850	*5230	2470	3380	1460	8.19
Line					*15830	8490	*11530	5450	7450	3220	(26.9)
-1.5 m (-5 ft)	*7650	*7650	*11110	7010	*7510	3620	*5380	2330	*3950	1820	7.18
-3.0 m (-10 ft)	*12010	*12010	*9250	7190	*6410	3700			*3660	2540	5.95
	*26480	*26480	*20390	15850	*14130	8160			*8070	5600	(19.5)

Boom : 5.1 m (16' 9") / arm : 2.6 m (8' 6") / Bucket : 0.76 m³ (0.99 yd³) SaE heaped / With rear dozer blade down

Load point height m (ft)	Load radius								At max. reach			
	1.5 m (5 ft)		3.0 m (10 ft)		4.5 m (15 ft)		6.0 m (20 ft)		7.5 m (25 ft)			
7.5 m (25 ft)									*3360	2640	6.37	
6.0 m (20 ft)							*3250	2870	*7410	5820	(20.9)	
4.5 m (15 ft)					*3830	2790	*8440	6150	*3420	1530	8.20	
3.0 m (10 ft)			*8540	8180	*5530	4240	*4400	2630	*2990	1740	8.52	
1.5 m (5 ft)			*18830	18030	*12190	9350	*9700	5800	*6590	3840	7.03	
Ground			*7620	7180	*6830	3860	*5010	2460	*3710	1660	3140	1330
Line			*16800	15830	*15060	8510	*11050	5420	*8180	3660	6920	2930
-1.5 m (-5 ft)	*7190	*7190	*11280	6890	*7570	3550	5420	2270			3780	1620
-3.0 m (-10 ft)	*15850	*15850	*24870	15190	*16690	7830	11950	5000			8330	3570
	*10590	*10590	*9950	7030	*6760	3590	*4660	2320			*3700	2180
	*23350	*23350	*21940	15500	*14900	7910	*10270	5110			*8160	4810
			*6800	*6800								
			*14990	*14990								

Boom : 5.1 m (16' 9") / arm : 2.6 m (8' 6") / Bucket : 0.76 m³ (0.99 yd³) SaE heaped / With rear dozer blade down

Load point height m (ft)	Load radius								At max. reach			
	1.5 m (5 ft)		3.0 m (10 ft)		4.5 m (15 ft)		6.0 m (20 ft)		7.5 m (25 ft)			
7.5 m (25 ft)									*3000	2250	6.96	
6.0 m (20 ft)							*2970	2920	*6610	4960	(22.8)	
4.5 m (15 ft)					*3420	2820	*2310	1810	*3110	1360	8.65	
3.0 m (10 ft)			*7140	*7140	*4940	4320	*4030	2650	*3220	1740	2910	1220
1.5 m (5 ft)			*15740	*15740	*10890	9520	*8880	5840	*7100	3840	6420	2690
Ground			*10650	7380	*6370	3910	*4720	2450	3850	1640	2860	1170
Line			*23480	16270	*14040	8620	*10410	5400	8490	3620	6310	2580
-1.5 m (-5 ft)	*4330	*4330	*8780	6880	*7320	3620	*5240	2300	3760	1570	2990	1220
-3.0 m (-10 ft)	*9550	*9550	*19360	15170	*16140	7980	*11550	5070	8290	3460	6590	2690
	*6700	*6700	*10760	6780	*7570	3490	5360	2210			3360	1400
	*14770	*14770	*23720	14950	*16690	7690	11820	4870			7410	3090
	*9430	*9430	*10640	6870	*7070	3490	*4990	2220			*3620	1820
	*20790	*20790	*23460	15150	*15590	7690	*11000	4890			*7980	4010
	*13120	*13120	*8110	7120	*5400	3640					*3220	3090
	*28920	*28920	*17880	15700	*11900	8020					*7100	6810













- Lifting capacity is based on ISO 10567.
- Lifting capacity of the Robex Series does not exceed 75% of the tipping load with the machine on firm, level ground or 87% of full hydraulic capacity.
- The load point is a hook located on the back of the bucket.
- (*) indicates the load limited by hydraulic capacity.

Lifting Capacity













R170W-9 MONO BOOM

 Rating over-front  Rating over-side or 360 degree

Boom : 5.1 m (16' 9") / Arm : 2.2 m (7' 3") / Bucket : 0.76 m³ (0.99 yd³) SAE heaped / With rear dozer blade down

Load point height m (ft)	Load radius										At max. reach			
	1.5 m (5 ft)		3.0 m (10 ft)		4.5 m (15 ft)		6.0 m (20 ft)		7.5 m (25 ft)		Capacity		Reach	
													m (ft)	
6.0 m (20 ft)	kg											*3710	2010	7.22
	lb											*8180	4430	(23.7)
4.5 m (15 ft)	kg							*4210	2760			*3680	1620	7.92
	lb							*9280	6080			*8110	3570	(26.0)
3.0 m (10 ft)	kg					*6040	4180	*4690	2610			3410	1450	8.25
	lb					*13320	9220	*10340	5750			7520	3200	(27.1)
1.5 m (5 ft)	kg					*7120	3810	*5190	2440	*3430	1660	3360	1410	8.26
	lb					*15700	8400	*11440	5380	*7560	3660	7410	3110	(27.1)
Ground	kg		*6770	*6770	*7590	3610	*5450	2330				3570	1500	7.94
Line	lb		*14930	*14930	*16730	7960	*12020	5140				7870	3310	(26.0)
-1.5 m (-5 ft)	kg	*6880	*6880	*10730	6950	*7310	3580	*5230	2300			*3640	1780	7.26
	lb	*15170	*15170	*23660	15320	*16120	7890	*11530	5070			*8020	3920	(23.8)
-3.0 m (-10 ft)	kg			*8720	7160	*6110	3680					*3140	2490	6.05
	lb			*19220	15790	*13470	8110					*6920	5490	(19.8)

Boom : 5.1 m (16' 9") / Arm : 2.6 m (8' 6") / Bucket : 0.76 m³ (0.99 yd³) SAE heaped / With rear dozer blade down

Load point height m (ft)	Load radius										At max. reach			
	1.5 m (5 ft)		3.0 m (10 ft)		4.5 m (15 ft)		6.0 m (20 ft)		7.5 m (25 ft)		Capacity		Reach	
													m (ft)	
6.0 m (20 ft)	kg											*3410	1810	7.63
	lb											*7520	3990	(25.0)
4.5 m (15 ft)	kg											*3410	1470	8.29
	lb											*7520	3240	(27.2)
3.0 m (10 ft)	kg							*4420	2620	*3380	1720	3160	1320	8.60
	lb							*9740	5780	*7450	3790	6970	2910	(28.2)
1.5 m (5 ft)	kg		*6600	*6600	*6800	3830	*4980	2430	3900	1640		3110	1280	8.61
	lb		*14550	*14550	*14990	8440	*10980	5360	8600	3620		6860	2820	(28.2)
Ground	kg	*6550	*6550	*7410	6810	*7460	3580	*5340	2290	3830	1580	3280	1350	8.31
Line	lb	*14440	*14440	*16340	15010	*16450	7890	*11770	5050	8440	3480	7230	2980	(27.3)
-1.5 m (-5 ft)	kg	*10160	*10160	*10600	6820	*7390	3500	*5290	2240			*3520	1570	7.66
	lb	*22400	*22400	*23370	15040	*16290	7720	*11660	4940			*7760	3460	(25.1)
-3.0 m (-10 ft)	kg			*9480	6980	*6500	3560	*4440	2300			*3240	2120	6.54
	lb			*20900	15390	*14330	7850	*9790	5070			*7140	4670	(21.5)
-4.5 m (-15 ft)	kg			*6100	*6100	*3870	3820							
	lb			*13450	*13450	*8530	8420							

1. Lifting capacity is based on ISO 10567.

2. Lifting capacity of the Robex Series does not exceed 75% of the tipping load with the machine on firm, level ground or 87% of full hydraulic capacity.

3. The load point is a hook located on the back of the bucket.

4. (*) indicates the load limited by hydraulic capacity.

STANDARD EQUIPMENT

ISO Standard cabin

All-weather steel cab with 360° visibility
 Safety glass windows
 Rise-up type windshield wiper
 Sliding fold-in front window
 Sliding side window(LH)
 Lockable door
 Hot & cool box
 Storage compartment & ashtray
 Transparent cabin roof-cover
 Radio & USB Player
 Handsfree mobile phone system with USB
 Sun visor
 12 volt power outlet (24V Dc to 12V Dc converter)

Booms

5.1m, 16' 9"

Computer aided power optimization (New CAPO) system

3-power mode, 2-work mode, user mode
 Auto deceleration & one-touch deceleration system
 Auto warm-up system
 Auto overheat prevention system

Automatic climate control

Air conditioner & heater
 Defroster

Self-diagnostics system

Starting Aid (air grid heater) for cold weather

Centralized monitoring

LED display
 Engine speed or Trip meter/Accel.
 Clock
 Gauges
 Fuel level gauge
 Engine coolant temperature gauge
 Hyd. oil temperature gauge
 Warnings
 Check engine
 Overload
 Communication error
 Low battery
 Air cleaner clogging
 Indicators
 Max power
 Low speed/High speed
 Fuel warmer
 Auto idle

Door and cab locks, one key

Two outside rearview mirrors

Adjustable air suspension seat with heater

Pilot-operated slidable joystick

Console box height adjust system

Four front working lights

Electric horn

Batteries (2 x 12V x 100 AH)

Battery master switch

Removable clean-out screen for cooler

automatic swing brake

Removable reservoir tank

Fuel pre-filter with fuel warmer

Boom holding system

Arm holding system

Accumulator for lowering work equipment

Electric Transducers

Lower frame under cover (Normal)

Viscous fan clutch

Rear-blade (550mm X 2,500mm)

Tires-dual (10.00-20-14PR)

Travel alarm

OPTIONAL EQUIPMENT

Fuel filler pump (35 L/min)

Beacon lamp

Safety lock valve for boom cylinder with overload warning device

Safety lock valve for arm cylinder

Single-acting piping kit (breaker, etc.)

Double-acting piping kit (clamshell, etc.)

Quick coupler

Arms

2.2m, 7' 3"

2.6m, 8' 6"

3.1m, 10' 2"

Climate control

Air conditioner only

Heater only

Cabin FOPS/FOG (ISO/DIS 10262 Level II)

FOPS (Falling Object Protective Structure)

FOG (Falling Object Guard)

Cabin ROPS (ISO 12117-2)

ROPS(Roll Over Protective Structure)

Cabin roof-steel cover

Cabin front guard-wire net

Cabin guard front

Wire net

Fine net

Cabin lights

Cabin front window rain guard

Undercarriage

Rear outrigger

Rear dozer and front outrigger

Rear and front outrigger

Rear outrigger and front dozer

Lower frame under cover (Additional)

Tool kit

Operator suit

Rearview camera

Seat

Adjustable air suspension seat

Mechanical suspension seat

Mechanical suspension seat with heater

Tires - dual (10.00 - 20 solid)

Fenders (Mudguards)

Pattern change valve (2 patterns)

Hi-MATE (Remote Management System)

* Standard and optional equipment may vary. Contact your Hyundai dealer for more information. The machine may vary according to International standards.

* The photos may include attachments and optional equipment that are not available in your area.

* Materials and specifications are subject to change without advance notice.

* All imperial measurements rounded off to the nearest pound or inch.