

CROWN

PR 4500 SERIES

Specifications
Rider Pallet Truck

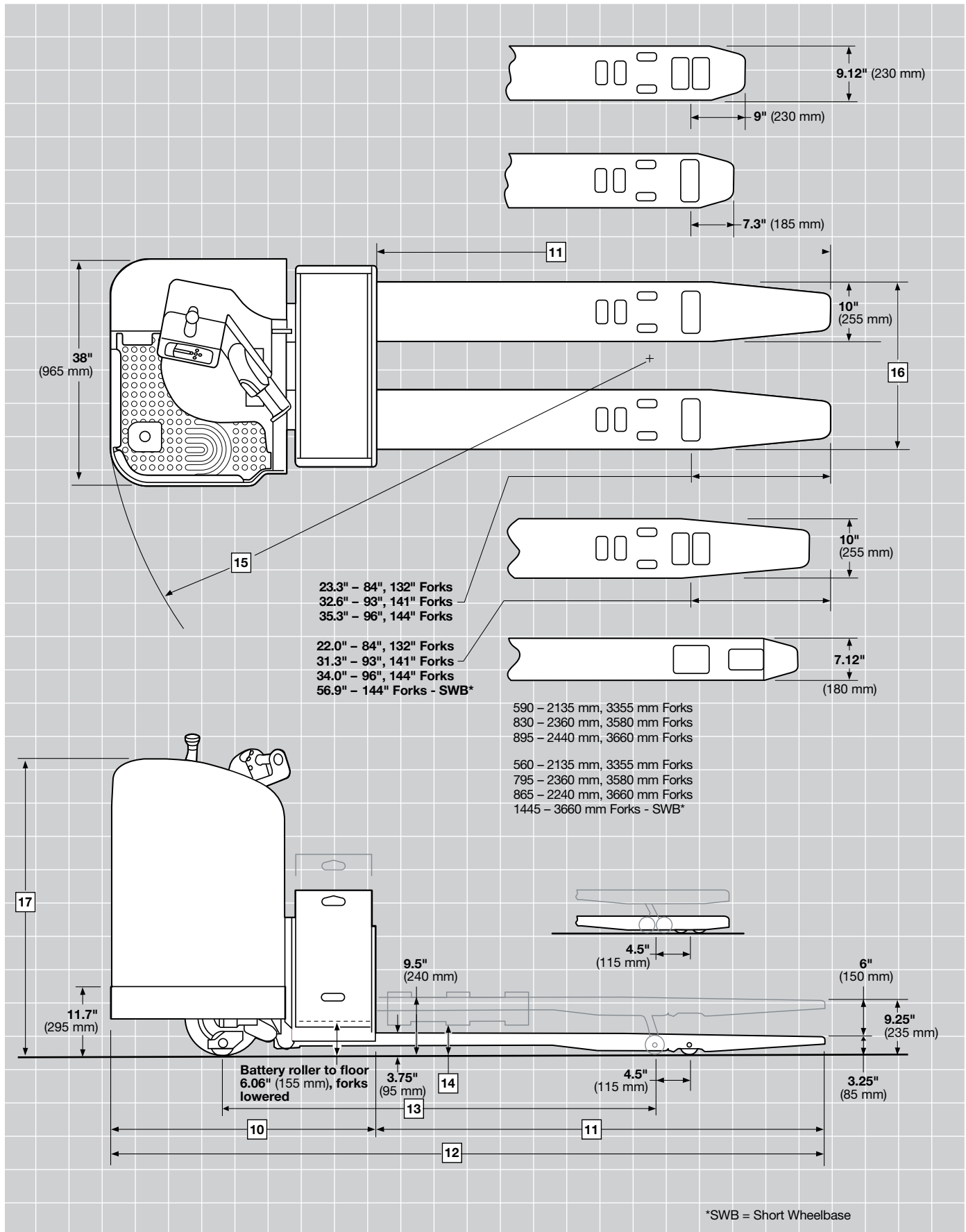



PR 4500 Series

Specifications

| | | | <i>Imperial</i> | <i>Metric</i> | | |
|---------------------|----|---------------------------------|------------------------------------|---------------|------------------|---------------------|
| General Info | 1 | Manufacturer | Crown Equipment Corporation | | | |
| | 2 | Model | PR 4500 | | | |
| | 3 | Load Capacity | lb kg | 6000 / 8000 | 2730 / 3640 | |
| | 4 | Power | Electric | 24 Volts | | |
| | 5 | Operator Type | Stand-up | Rider | | |
| Dimensions | 8 | Lift Height | in mm | 9.25 | 235 | |
| | 9 | Lift | in mm | 6 | 150 | |
| | 10 | Head Length | in mm | 44.7 | 1135 | |
| | 16 | Outside Fork Spread | Standard Tip | in mm | 22 / 27 | 560 / 685 |
| | | | Extended Tip | in mm | 23 / 28 | 585 / 710 |
| | 17 | Operator Backrest Height | Standard | in mm | 50.5 | 1285 |
| +5" Extension | | | in mm | 55.5 | 1410 | |
| +10" Extension | | | in mm | 60.5 | 1535 | |
| Performance | 18 | Speed Travel | Power Unit First / Forks First | | | |
| | | | Empty | mph km/h | 8.0 - 9.0* / 6.5 | 12.9 - 14.5* / 10.5 |
| | | | 4000 lb (1820 kg) | mph km/h | 7.0 / 5.7 | 11.3 / 9.2 |
| | | | 6000 lb (2730 kg) | mph km/h | 6.3 / 5.1 | 10.1 / 8.2 |
| | | | 8000 lb (3640 kg) | mph km/h | 6.0 / 5.0 | 9.7 / 8.0 |

*Top travel speed with optional productivity package

| | | | <i>Imperial</i> | <i>Metric</i> | |
|-------------------------|--------------------|---|---|----------------------|---------------------|
| Wheels and Tires | Model | | PR 4500 - 60/80 | | |
| | Drive Tire | in mm | 13 x 4.5 x 8 Poly | 330 x 115 x 205 Poly | |
| | Casters | in mm | 2 - 4 x 2.5 Poly | 2 - 100 x 65 Poly | |
| | Load Wheels | in mm | 2 - 3.25 x 6.5 (-302) | | 2 - 85 x 165 (-302) |
| | | -301 | Moderate cut/tear resistance, high capacity. High capacity transport. Not for dock use. | | |
| | | -302 | Highest cut/tear resistance offered. Extremely high capacity, low rolling resistance. Docks, rough floors and floor debris. | | |
| -401 | | Combines good cut/tear resistance and very high capacity. Use where nothing else works. | | | |

PR 4500 Series

Specifications

| PR 4500 Series | | | Standard-Tip Forks | | | | | | | |
|----------------|-------------------|--------------------------------|--------------------|-------|--------|------|----------|------|--------|------|
| | | | Imperial | | Metric | | Imperial | | Metric | |
| Forks | | Nominal Fork Length | | in mm | 36 | 915 | 42 | 1065 | 48 | 1220 |
| | 11 | Actual Fork Length | | in mm | 35.75 | 910 | 41.75 | 1060 | 47.75 | 1215 |
| | 12 | Overall Length | | in mm | 80.50 | 2045 | 86.50 | 2195 | 92.50 | 2350 |
| | 13 | Wheelbase – Forks Raised | | in mm | 52.44 | 1330 | 58.44 | 1485 | 64.44 | 1635 |
| | 14 | Grade Clearance – Forks Raised | | % | 31 | 31 | 28 | 28 | 26 | 26 |
| | 15 | Turning Radius – Forks Raised | | in mm | 74.44 | 1890 | 80.44 | 2045 | 86.44 | 2195 |
| | 7 | Truck Weight without Battery | 6000 lb (2720 kg) | lb kg | 1738 | 790 | 1754 | 800 | 1830 | 830 |
| | 8000 lb (3625 kg) | | lb kg | 1757 | 800 | 1781 | 810 | 1865 | 850 | |

| PR 4500 Series | | | Standard-Tip Forks | | | | | | | |
|----------------|-------------------|--------------------------------|--------------------|-------|--------|------|----------|------|--------|------|
| | | | Imperial | | Metric | | Imperial | | Metric | |
| Forks | | Nominal Fork Length | | in mm | 54 | 1370 | 60 | 1525 | 96 | 2440 |
| | 11 | Actual Fork Length | | in mm | 53.75 | 1365 | 59.75 | 1520 | 95.75 | 2430 |
| | 12 | Overall Length | | in mm | 98.50 | 2500 | 104.50 | 2655 | 140.50 | 3570 |
| | 13 | Wheelbase – Forks Raised | | in mm | 70.44 | 1790 | 76.44 | 1940 | 112.44 | 2855 |
| | 14 | Grade Clearance – Forks Raised | | % | 24 | 24 | 22 | 22 | 15 | 15 |
| | 15 | Turning Radius – Forks Raised | | in mm | 92.44 | 2350 | 98.44 | 2500 | 134.44 | 3415 |
| | 7 | Truck Weight without Battery | 6000 lb (2720 kg) | lb kg | 1846 | 840 | 1862 | 845 | 2012 | 915 |
| | 8000 lb (3625 kg) | | lb kg | 1889 | 860 | 1913 | 870 | 2077 | 945 | |

| PR 4500 Series | | | Extended-Tip Forks | | | | | | | |
|----------------|-------------------|--------------------------------|--------------------|-------|--------|------|----------|------|--------|------|
| | | | Imperial | | Metric | | Imperial | | Metric | |
| Forks | | Nominal Fork Length | | in mm | 84 | 2135 | 93 | 2360 | 96 | 2440 |
| | 11 | Actual Fork Length | | in mm | 83.70 | 2125 | 93 | 2360 | 95.75 | 2430 |
| | 12 | Overall Length | | in mm | 128.50 | 3265 | 137.75 | 3500 | 140.50 | 3570 |
| | 13 | Wheelbase – Forks Raised | | in mm | 87.44 | 2220 | 87.44 | 2220 | 87.44 | 2220 |
| | 14 | Grade Clearance – Forks Raised | | % | 20 | 20 | 20 | 20 | 20 | 20 |
| | 15 | Turning Radius – Forks Raised | | in mm | 106.12 | 2695 | 106.12 | 2695 | 106.12 | 2695 |
| | 7 | Truck Weight without Battery | 6000 lb (2720 kg) | lb kg | 1944 | 885 | 2025 | 920 | 2040 | 930 |
| | 8000 lb (3625 kg) | | lb kg | 2004 | 910 | 2085 | 950 | 2100 | 955 | |

| PR 4500 Series | | | Extended-Tip Forks | | | | | | | |
|----------------|-------------------|--------------------------------|--------------------|-------|--------|------|----------|------|--------|------|
| | | | Imperial | | Metric | | Imperial | | Metric | |
| Forks | | Nominal Fork Length | | in mm | 132 | 3355 | 141 | 3580 | 144 | 3660 |
| | 11 | Actual Fork Length | | in mm | 131.75 | 3345 | 140.75 | 3575 | 143.75 | 3650 |
| | 12 | Overall Length | | in mm | 176.50 | 4485 | 185.50 | 4710 | 188.50 | 4790 |
| | 13 | Wheelbase – Forks Raised | | in mm | 135.44 | 3440 | 135.44 | 3440 | 135.44 | 3440 |
| | 14 | Grade Clearance – Forks Raised | | % | 16 | 16 | 16 | 16 | 16 | 16 |
| | 15 | Turning Radius – Forks Raised | | in mm | 154.12 | 3915 | 154.12 | 3915 | 154.12 | 3915 |
| | 7 | Truck Weight without Battery | 6000 lb (2720 kg) | lb kg | 2457 | 1115 | 2538 | 1155 | 2553 | 1160 |
| | 8000 lb (3625 kg) | | lb kg | | | | | | | |

| PR 4500 Series | | | Extended-Tip Forks | | | |
|----------------|-------------------|--------------------------------|--------------------|--------|--------|------|
| | | | Imperial | Metric | | |
| Forks | | Nominal Fork Length | | in mm | 144** | 3660 |
| | 11 | Actual Fork Length | | in mm | 144 | 3660 |
| | 12 | Overall Length | | in mm | 188.50 | 4790 |
| | 13 | Wheelbase – Forks Raised | | in mm | 108.50 | 2755 |
| | 14 | Grade Clearance – Forks Raised | | % | 7.9 | 7.9 |
| | 15 | Turning Radius – Forks Raised | | in mm | 128.30 | 3260 |
| | 7 | Truck Weight without Battery | 6000 lb (2720 kg) | lb kg | 2688 | 1220 |
| | 8000 lb (3625 kg) | | lb kg | | | |

**Shorter wheelbase and turning radius.

Maximum Battery Size

13.19" wide x 31.12" long x 31.62" high (335 wide x 790 long x 805 mm high)

Batteries

24 volt - 750 amp hour - 15.2 kWh
Min/Max weight 975/1500 lb (445/680 kg)

Standard Equipment

- 24-volt fused electrical system
- Access 1 2 3[®] Comprehensive System Control
- Access 1 2 3 Display (includes BDI with lift lockout, hour meters, event codes, PIN code access and three performance levels)
- e-GEN[®] braking system with automatic parking brake
- Crown manufactured AC traction motor
- Operator driveability features
 - Spacious variable side-stance compartment
 - Suspended floorboard
 - Premium platform cushion
 - Platform area - 485 sq in (3130 sq mm)
 - Large, entry/exit opening
 - Power steering
 - Profiled, padded backrest
 - Padded knee cushion
 - Urethane covered control handles with tactile feedback
 - Entry bar safety switch
- Polyurethane load wheels
- Heavy-duty articulating shim free casters (fork length < 96" [2440 mm])
- Quick-adjust caster with torsion bar (fork length > 96" [2440 mm])
- InfoPoint[®] System with Quick Reference Guide
- 175 amp battery connector
- Color-coded wiring
- Steel power unit doors
- Lift-off left and right battery retainers
- Key switch
- Horn

Optional Equipment

- Productivity package
- 48", 60" or 72" high (1220, 1525 or 1830 mm high) load backrest (hinged, lift-off or bolt-on)
- Quick adjustment caster (< 96" forks [2440 mm])
- Torsion bar with quick adjustment caster (< 96" fork [2440 mm])
- Battery retainer interlock switch
- Quick battery disconnect handle (right side only)
- Battery compartment rollers
- Work Assist[®] Accessories:
 - LED flashing light
 - Work lights
 - Fan
 - Storage pouch
 - Pad clip and hook
 - Shrink wrap tray
- Storage module
- 7" (180 mm) wide fork (6000 lb [2720 kg] only)
- Drive tire and load wheel options
- Toggle switch in lieu of key
- Tandem load wheels
- Dual load wheels
- Cold and corrosion conditioning
- Special color paint
- Skid adapter
- InfoLink[®] Ready System
- Wider Compartment
- Steer tiller and backrest extensions

Operator Area and Controls

The PR 4500 Series incorporates numerous design features to improve operator comfort and productivity. The side-stance position provides the operator with maximum visibility. The compartment cradles the operator with a wrap-around chassis while the suspended floorboard with premium floor mat provides maximum comfort.

The PR has a left hand steer tiller with full-time power steering. Full function control is provided for the right hand to control travel direction and speed, raise, lower and horn.

Electrical System

Heavy-duty 24-volt electrical system for demanding warehouse, dock and transport applications. Crown-manufactured AC drive motor is application designed for reliability and ease of service.

Access 1 2 3[®] Comprehensive System Control with AC Traction

This system provides unmatched truck control and system performance in:

- Traction control
- Operator interface
- Diagnostics

Crown's technology provides a closed-loop traction control system which maintains speed throughout the battery charge.

The large Crown-manufactured AC traction motor specifically designed for lift truck applications, provides improved acceleration and plug reversal contributing to greater productivity. The Access[™] display offers seven hour meter readouts and odometer. The operator message mode includes BDI, truck hours, odometer, trip odometer, or timer. Built-in PIN-code (up to 25) capability that can be programmed by customers.

The Access display also includes a full featured on-board service tool. The service technician can actively view inputs and outputs during truck operation. Event code history including the last 16 event codes are accessible. No service key, laptop, or handset required.

Access controller has full-time management control of traction and other system inputs and outputs. Access 1 2 3 technology simplifies the system by reducing componentry including contactors, relays, and other hard-wired components.

InfoPoint[®]

InfoPoint System allows your technician to troubleshoot without complicated schematics, wiring diagrams or cumbersome service manuals for over 95% of your repairs. Simplicity is complete with InfoPoint Quick Reference Guide, color-coded component maps, and "information nuggets" located on the truck.

Information on time consists of clearly labeling each component and providing an area map showing the component location. A Quick Reference Troubleshoot Guide is supplied with each truck showing display operation, code definitions, and an overall component ID of the entire truck.

Hydraulics

A heavy-duty pump, motor, reservoir and control are assembled into one unit. A centrally located lift cylinder, mounted vertically, is equipped with long-life polyurethane packing. A pressure compensating flow control valve is an integral part of the valve block and regulates maximum lowering speed. Over-load valve protects hydraulic components.

Drive Unit

Crown-manufactured gears are hard finished and dual machined for high quality. All gear drive from drive motor to drive wheel axle. Drive tire axle is mounted in the drive unit on both sides for maximum strength in rough floor or docking applications. Drive unit is top and bottom mounted. Top mount is a large, tapered roller bearing for vertical or horizontal forces. Bottom mount has four shock mounted rollers on drive unit running in a hardened steel roller race. Gear train runs in an oil-filled, sealed housing.

Caster System

Standard on the PR 4500 Series are shim free, spring loaded, articulating, stabilizing casters for fork lengths up to 96" (2440 mm). Quick adjustment casters with torsion bar are standard on fork lengths above 96" (2440 mm). Quick adjustment casters or quick adjustment casters with torsion bar is optional for 96" (2440 mm) forks and below.

Quick adjustment casters adjust quickly to enable braking, traction, steer effort and stability to become balanced. This system can also increase tire life by as much as 60 percent by permitting more tire wear. The torsion bar suspension is designed to maximize stability on tall unwieldy and less stable loads.

Fork Assembly

Fork width - 9.12" (230 mm) on standard-tip fork models, 10" (255 mm) on extended-tip fork models. Fork spread - 22" and 27" (560 and 685 mm) on standard-tip models. 23" - 26" (585 - 660 mm) spread available in one inch increments. 23" and 28" (585 and 710 mm) standard on extended-tip models. Fork spreads from 24"-27" (610 - 685 mm) available in one-inch increments. Fork lengths - 36", 42", 48", 54", 60", 96" (915, 1065, 1220, 1370, 1525, 2440 mm) with standard-tip; 84", 93", and 96" (2135, 2360, and 2440 mm) forks available with extended-tip design for shorter wheelbase.

To facilitate pallet entry/exit Crown has engineered several features into their fork assembly. Standard-tip forks have pallet entry rollers to lift fork over bottom board of pallet. Rollers are made of high molecular weight polyethylene with .75" (19 mm) axle and roll pin.

Extended-tip fork design has totally enclosed tip with full length convex bottom surface creating an entry ramp. Ramp design helps fork glide over bottom boards of pallet and keeps welded edges from touching boards of pallet.

Abrasion resistant steel entry/exit slides on both sides of each fork which have convex bottom surfaces to prevent snagging as forks move over bottom boards of pallet. One piece design with radial edges are welded away from contact point of slide.

Exit roller design prevents load wheel from dropping after crossing bottom board. The 3" (75 mm) wide, steel exit roller is positioned directly behind the load wheel to keep the fork rolling. Entry/exit slide design also assists in trouble-free pallet entry/exit.

Fork adjustability is done at the toe with no need to remove a cover plate. Fork heel height adjustment is done quickly without removing battery. Quick and easy fork adjustment promotes servicing of fork assembly to keep pallet entry/exit productive.

Pull rod design incorporates a replaceable "tenon" for fast servicing of pull rod while still in the truck. Damage related to impacts is limited to the replaceable "tenon", not the entire pull rod.

Power Unit Structure

Heavy gage steel is used in the platform and power unit skirt with additional steel reinforcement where needed.

The power unit door and motor cover also utilize heavy steel for protection of critical components and long term durability. The power unit door swings out for easy access to components.

e-GEN® Braking System

Variable regenerative motor braking is optimized and virtually eliminates brake maintenance. When the truck is traveling, if the operator releases the brake pedal, removes travel input request or reverses direction e-GEN braking is applied.

The closed loop Access 1 2 3 traction control will keep the truck static until a travel input is requested, even when operating on a grade.

Automatic electric parking brake activates when the operator releases the brake pedal and the truck has been stationary for four seconds, the truck is keyed off, or the battery has been disconnected.

Pallet Planning Guide

On standard-tip fork models, the load wheel will drop in the second opening of the pallet when "A" or "B" dimension equals the nominal fork length. On extended-tip fork models, the load wheel will drop in the first opening of the second pallet. On models with a single load wheel, the "C" dimension should be 6" (150 mm) maximum and the "D" dimension should be 14" (355 mm) minimum. On models with tandem load wheels, the "C" dimension should be 6" (150 mm) maximum and the "D" dimension should be 17" (430 mm) minimum. Customers that need tandem load wheel trucks, but use pallets with smaller openings, may be accommodated if the maximum lift height of the truck is reduced. Contact your local Crown dealer for details.

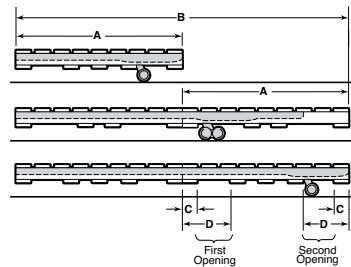
**Warning Device Options**

Audible or Visual Alerts

Safety considerations and dangers associated with audible travel alarms and lights include:

- Multiple alarms and/or lights can cause confusion.
- Workers ignore the alarms and/or lights after day-in and day-out exposure.
- Operator may transfer the responsibility for "looking out" to the pedestrians.
- Annoys operators and pedestrians.

Other Options Available

Contact factory for additional options.

Dimensions and performance data given may vary due to manufacturing tolerances. Performance is based on an average size vehicle and is affected by weight, condition of truck, how it is equipped and the conditions of the operating area. Crown products and specifications are subject to change without notice.

CROWN

Crown Equipment Corporation

New Bremen, Ohio 45869 USA

Tel 419-629-2311

Fax 419-629-3796

crown.com

You can count on Crown to build lift trucks designed for safe operation, but that's only part of the safety equation. Crown encourages safe operating practices through ongoing operator training, safety-focused supervision, maintenance and a safe working environment. Go to crown.com and view our safety section to learn more.

Because Crown is continually improving its products, specifications are subject to change without notice.

Crown, the Crown logo, the color beige, the Momentum symbol, Access, Access 1 2 3, e-GEN, InfoLink, InfoPoint, and Work Assist are trademarks of Crown Equipment Corporation.

Copyright 2007-2018 Crown Equipment Corporation
SF14835 Rev. 02-18
Printed in U.S.A.