

ENGINE AND RELATED ITEMS:

- Air cleaner, double element, dry
- Engine, Komatsu SAA6D140E-5
- Variable speed cooling fan, with fan guard

ELECTRICAL SYSTEM:

- Alternator, 50 amp, 24 V
- Batteries, 170 Ah, 2 x 12 V
- Starting motors, 11kW
- Working lights 2 (boom and RH)
- Auto decelerator
- Electric priming pump

UNDERCARRIAGE:

- 600 mm 24" triple grouser
- 8 track/3 carrier rollers (each side)
- 9 track/3 carrier rollers (each side)(LC)
- Hydraulic track adjusters (each side)
- Variable track gauge
- Sealed track

GUARDS AND COVERS:

- Dust-proof net for radiator and oil cooler
- Pump/engine room partition cover
- Travel motor guards
- Strengthened revolving frame underguard

OPERATOR ENVIRONMENT:

- Damper mount, all-weather, sound-suppressed cab with tinted safety glass windows, lockable door, intermittent window wiper and washer, floor mat, cigarette lighter and ashtray
- Multi-function color monitor, fuel control dials, service meter, gauges (coolant temperature, hydraulic oil temperature and fuel level), caution lights (electric charge, engine oil pressure, and air cleaner clogging), indicator lights (engine preheating and swing lock light) level check lights (coolant and engine oil level), self-diagnostic system with trouble data memory
- Seat, fully adjustable with suspension
- Cab with pull-up type front window
- Rear view mirror (LH & RH)

HYDRAULIC CONTROLS:

- Fully hydraulic, with Open-Center Load-Sensing (OLSS) and engine speed sensing (pump and engine mutual control system)
- One gear pump for control circuit
- Two axial piston motors for swing with single-stage relief valve
- One axial piston motor per track for travel with counter balance valve
- Two variable capacity piston pumps
- Control valves, 5+4 spools (boom, arm, bucket, swing, and travel)
- Control levers, wrist control levers for arm, boom, bucket, and swing with PPC system
- Control levers and pedals for steering and travel with PPC system
- Oil cooler
- In-line filter
- L mode system
- Two-mode setting for boom
- Power max function

DRIVE AND BRAKE SYSTEM:

- Brakes, hydraulic lock travel brakes, oil disc parking
- Hydrostatic two travel speed system with planetary triple reduction final drive

OTHER STANDARD EQUIPMENT:

- Automatic swing holding brake
- Corrosion resister
- Counterweight, 10750 kg 23,700 lb
- Horn, electric
- Marks and plates, English
- Paint, Komatsu standard
- Large handrails
- One-touch engine oil drainage
- PM tune-up service connector
- Travel alarm
- Rear reflector
- Anti-slip plates
- Water separator
- Catwalk

- Alternator, 75 Amp, 24 V
- Arms (Backhoe):
PC600-8R:
—3500 mm 11'6" arm assembly
—3500 mm 11'6" HD arm assembly
—4300 mm 14'1" arm assembly
—5200 mm 17'1" arm assembly
—2900 mm 9'6" SE arm assembly
- Auto air conditioner
- Automatic greasing
- Booms (Backhoe):
—7660 mm 25'2" boom assembly
—7300 mm 23'11" HD boom assembly
—6600 mm 21'8" SE boom assembly

- Cab front guard (ISO 10262 level 2)
- Cab with fixed front window
- Counterweight 13500kg 29,800 lb
- 12V electric supply
- Fire extinguisher
- Full length track guard
- General tool kit
- Grease gun, electric operated, with indicator
- Interconnected horn and warning light
- Large-capacity batteries
- Loading shovel attachments
- Lower wiper
- OPG top guard
- Radio AM/FM

- Rain visor
- Seat belt 78 mm 3", 50 mm 2"
- Shoes:
—600 mm 24" double grouser for backhoe
—750 mm 29.5" triple grouser for backhoe
—900 mm 35.5" triple grouser for PC600LC-8R backhoe only
- Spare parts for first service
- Step light with timer
- Sun visor
- Track frame undercover (center)
- Vandalism protection locks
- Working lights 2 (on cab)

www.Komatsu.com

Printed in Japan 200706 IP.As(10)

KOMATSU[®]

CEN00174-01

Materials and specifications are subject to change without notice.
KOMATSU is a trademark of Komatsu Ltd. Japan.

KOMATSU[®]

PC600/600LC-8R BACKHOE
PC600/600LC-8R LOADING SHOVEL



Photo may include optional equipment.

HYDRAULIC EXCAVATOR

HORSEPOWER
Gross:323 kW 433 HP @ 1800 rpm
Net:320 kW 429 HP @ 1800 rpm

OPERATING WEIGHT
Backhoe:57300–60000 kg
126,320–132,280 lb
Loading shovel:61300–62300 kg
135,140–137,350 lb

PC
600



WALK-AROUND

GALEO

Genuine Answers for Land and Environment Optimization

Productivity Features

- **High Work Equipment Speed**
Increased arm dumping and bucket dumping speed realize efficient loading operation.
- **Lifting Mode**
The lifting mode increases the lifting force and capacity 14%.
- **Large Digging Force**
Pressing the Power Max function button temporarily increases the digging force 8%.
- **Two-mode Setting for Boom**
Switch selection allows either powerful digging or smooth boom operation.
- **Excellent Swing Performance** is achieved by twin-swing motor system even on slope.
- **Large Drawbar Pull and Steering Force** provide excellent mobility.

See page 5.

Excellent Reliability and Durability

- **Strengthened Boom and Arm**
- The fuel reliability is improved by adding **Fuel Main-filter and Water Separator** working against low grade fuel.
- **KMAX Bucket** offers superior wear-resistance for specific use in quarry. (optional)
- **Fuel Pre-filter** with water separator equipped as standard
- **O-ring Face Seals**, which have excellent sealing performance, are used for the hydraulic hoses.
- **High-pressure In-line Filtration**
The cool-running hydraulic system is protected with the most extensive filtration system available, including a high pressure in-line filter for each main pump.
- **Highly Reliable Electronic Devices**
Exclusively designed electronic devices have passed severe testing.
 - Controller • Sensors • Connectors • Heat resistant wiring

See page 6, 7.



Easy Maintenance

- **Easy Cleaning of Cooling Unit**
Fan reverse-rotation function facilitates clogged radiator cleaning.
- **Radiator and Oil Cooler** are easily detachable from **Full Open Type Engine Hood**.
- **Centralized Arrangement of Engine Checkpoints**
- **Work on Machine Anti-slip Plates for Safe**
- **Large Handrail, Step and Catwalk** provide easy access to the engine and hydraulic equipment.
- **Electric Priming Pump** installed.

See page 10.

Ecology and Economy Features

- **High Power Komatsu SAA6D140E-5 Engine**
 - Powerful turbocharged and air-to-air aftercooled Komatsu SAA6D140E-5 engine provides **320 kW** 429 HP.
 - Offers high power and low fuel consumption.
 - Equipped with an electronically controlled variable speed fan.

- **Economy Mode Four-level Setting**

Enables operator to select the appropriate Economy mode level to match production requirement with lowest fuel consumption.

- **Reduction of Ambient Noise**

- Meets the EU Stage 2 noise regulations.
- Electronically controlled variable speed fan drive
- Large hybrid fan
- Glasswool-furnished low-noise muffler and noise reducing cover around the muffler

See page 4.



Photo may include optional equipment.

Working Environment

- **Large Comfortable Cab**
 - Low noise and vibration with cab damper mounting
 - Large-capacity air conditioner (optional)
 - Pressurized cab prevents external dust from entering
 - OPG top guard level 2 (by ISO 10262 standard) capable with optional bolt-on top guard.

See page 8.



Advanced Monitor Features

- Machine condition can be checked with Equipment Management Monitoring System (EMMS). See page 11.
- Two working modes combine with lifting mode for maximum productivity. See page 5.

HORSEPOWER
Gross:323 kW 433 HP @ 1800 rpm
Net:320 kW 429 HP @ 1800 rpm

OPERATING WEIGHT
Backhoe
57300 – 60000 kg
126,320 – 132,280 lb
Loading shovel
61300 – 62300 kg
135,140 – 137,350 lb

PRODUCTIVITY & ECOLOGY FEATURES

Komatsu Technology

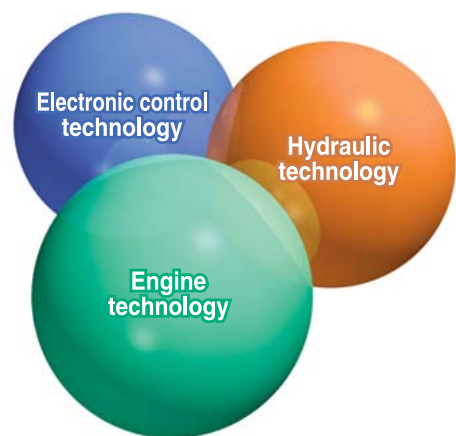

Komatsu develops and produces all major components, such as engines, electronics and hydraulic components, in house. With this "Komatsu Technology," and adding customer feedback, Komatsu is achieving great advancements in technology. To achieve both high levels of productivity and economical performance, Komatsu has developed the main components with a total control system. The result is a new generation of high performance and environment friendly excavators.

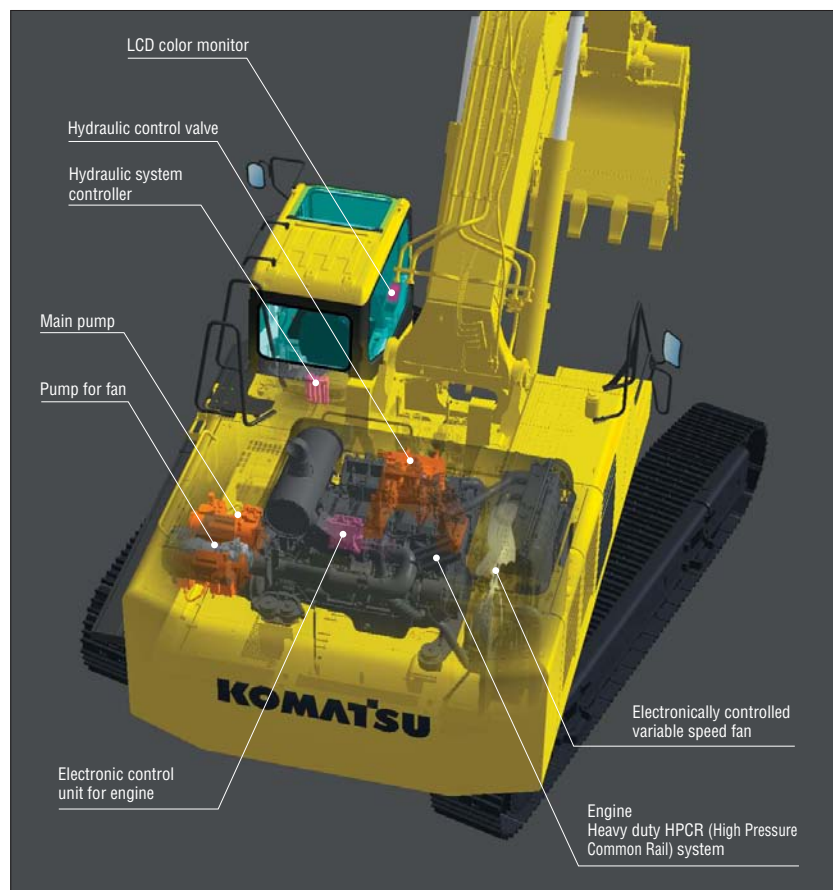

High Power Komatsu SAA6D140E Engine

Powerful turbocharged and air-to-air aftercooled Komatsu SAA6D140E-5 engine provides **320 kW** 429 HP. This Komatsu SAA6D140E engine actualizes high-power to low fuel consumption with the optimum fuel injection by electronic heavy duty HPCR (High Pressure Common Rail) fuel injection system.

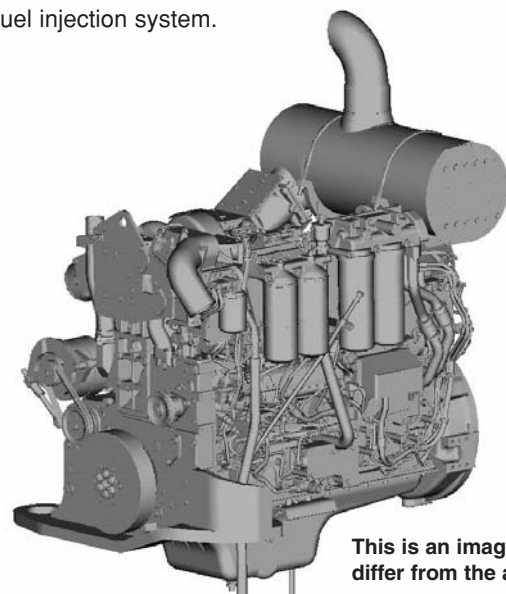

This is an image photo: may differ from the actual engine.

Electronically Controlled Variable Speed Fan Contributes to Low Fuel Consumption and Low Noise

The electronic control system sets the rotational speed of the cooling fan according to the coolant, hydraulic oil, and ambient temperature; effectively uses the engine output to prevent wasteful fuel consumption; and reduces noise during low-speed fan rotation.



Lower and Economical Fuel Consumption Using Economy Mode

Enables operator to set the Eco mode to up to four levels according to working conditions so that production requirement is achieved at lowest possible fuel consumption.

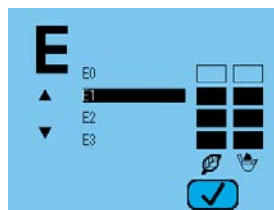

Reduction of Ambient Noise

Reduced noise by adoption of an electronically controlled variable speed fan drive, large hybrid fan, low-noise muffler and cover with glasswool, to meet EU Stage 2 noise regulations.

Work Equipment Speed Increased

An arm quick return circuit is provided for arm dumping. This returns a portion of oil flow directly to the hydraulic tank at arm dumping to reduce the hydraulic pressure loss. Combined with increased bucket dumping speed, faster loading work is realized.

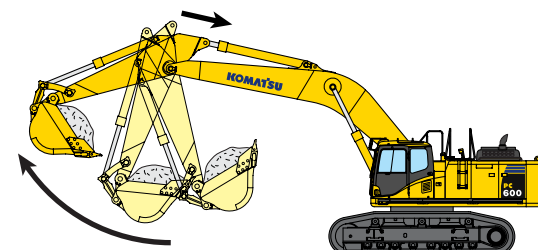

Large Drawbar Pull and Steering Force

Since the machine has a large drawbar pull and a high steering force, it demonstrates excellent mobility even when it is being used on inclined sites.

Large Digging Force

With the addition of one-touch Power Max. function digging force has been further increased. (8.5 seconds of operation)

Maximum arm crowd force (ISO):
228 kN (23.3t) → **246 kN (25.1t)** **8% UP**
(with Power Max.)

Maximum bucket digging force (ISO):
294 kN (30.0t) → **317 kN (32.3t)** **8% UP**
(with Power Max.)

Lifting Mode

When lifting mode is selected, lifting capacity increases 17% by raising hydraulic pressure. The work equipment and swing speeds are lowered at the same time to provide additional control.

Two-mode Setting for Boom

Smooth mode provides easy operation for gathering blasted rock and scraping operations. When maximum digging force is needed, switch to **power mode** for more effective excavating.

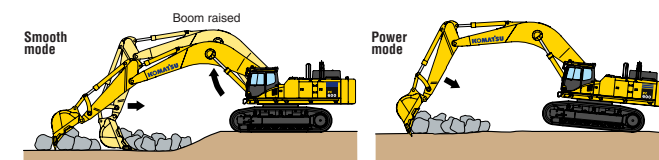

Working Mode Selection

Hydraulics

Unique two-pump system assures smooth compound movement of the work equipment. OLSS (Open Center Load Sensing System) controls all pumps for efficient engine power use. This system also reduces hydraulic loss during operation.

Power and Economy Mode

The PC600-8R excavator is equipped with two working modes. Each mode is designed to match engine speed, pump speed, and system pressure to the current application, giving the operator flexibility to match equipment performance to the job at hand.

Working Mode	Application	Advantage
P	Power Mode	<ul style="list-style-type: none"> Maximum production/power Fast cycle time
E (E0, E1, E2, E3)	Economy Mode	<ul style="list-style-type: none"> Good cycle time Good fuel economy
L	Lifting Mode	<ul style="list-style-type: none"> Hydraulic pressure is increased 17%.

Multi-Function Color Monitor

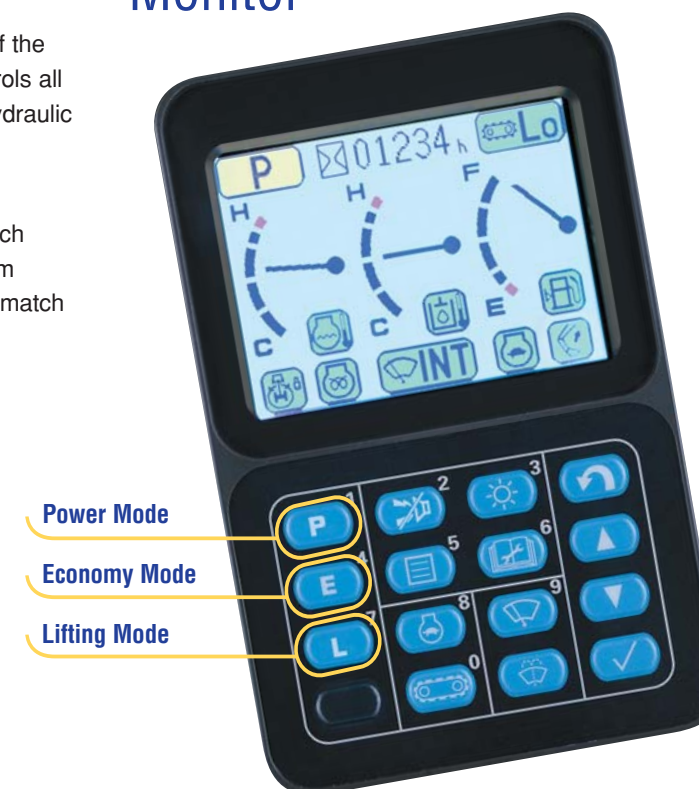

RELIABILITY FEATURES

Excellent Reliability and Durability

Strengthened Boom and Arm

Thanks to the large cross-sectional structure employing a high tensile strength steel with a thick plate, partition wall, etc., the boom and arm exhibit excellent durability and are highly resistant to bending and torsional stress.

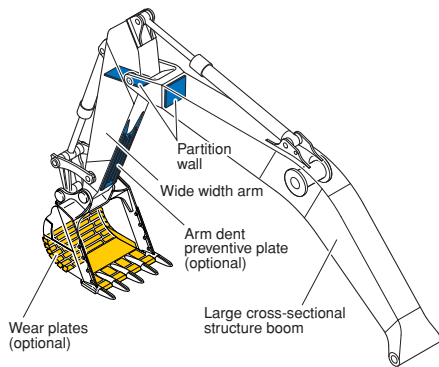

O-ring Face Seal

The hydraulic hose seal method has been changed from a conventional taper seal to an O-ring seal. This provides improved sealing performance during operation.

Frame Structure

The revolving frame mount and center frame mount on the swing circle are no welding structure so that force is transmitted directly to the thick plate of the frame without passing through any welding.

Fuel Pre-filter (with Water Separator)

Removes water and contaminants from in the fuel to enhance the fuel system reliability.



High-pressure In-line Filtration

The PC600-8R has the most extensive filtration system available, providing in-line filters as standard equipment. An in-line filter in the outlet port of each main hydraulic pump reduces failures caused by contamination.

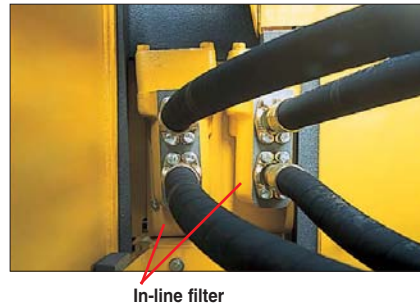

Metal Guard Rings

Metal guard rings protect all the hydraulic cylinders and improve reliability.

Heat-resistant Wiring

Heat-resistant wiring is utilized for the engine electric circuit and other major component circuit

Fuel Main-filter

The reliability of fuel systems is improved, because fuel main-filter additionally installed removes contamination and sludge contained in fuel.



Sturdy Undercarriage

The undercarriage is strengthened to provide excellent reliability and durability when working on rocky ground or blasted rock.

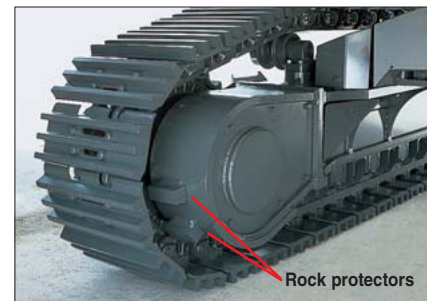

Sturdy guards shield the travel motors and piping against damage from rocks. (Rock protectors are optional.)



Track roller guard (full length) (optional)

Strengthened Revolving Frame Underguard

Guards the machine body against being hit by rocks from below and prevents hydraulic components and the engine from being damaged.

Water Separator

Removes water from the fuel and improves the reliability of fuel systems.



Strengthened Quarry Bucket for Provides Outstanding Wear-resistance (optional)

The bucket for specific use in quarry is impact and wear resistant, providing high performance and long life. Koma-hard materials* provide excellent wear resistance. Combined with adoption of long-life KMAX tooth, durability of bucket is drastically enhanced.

* Koma-hard materials (KVX materials):
Komatsu developed, wear-resistant, reinforced materials. Brinell hardness: 500 or more (180kgf/mm² class). Features high wear-resistance and little quality change by the heat generated during rock loading, maintaining the hardness for a long term.

KMAX Tooth for Quarry Bucket

- Unique bucket tooth shape superior digging performance
- Long-term high sharpness
- Great penetration performance
- Hammerless, safe, and easy tooth replacement (Tooth replacement time: Halves the conventional machine.)

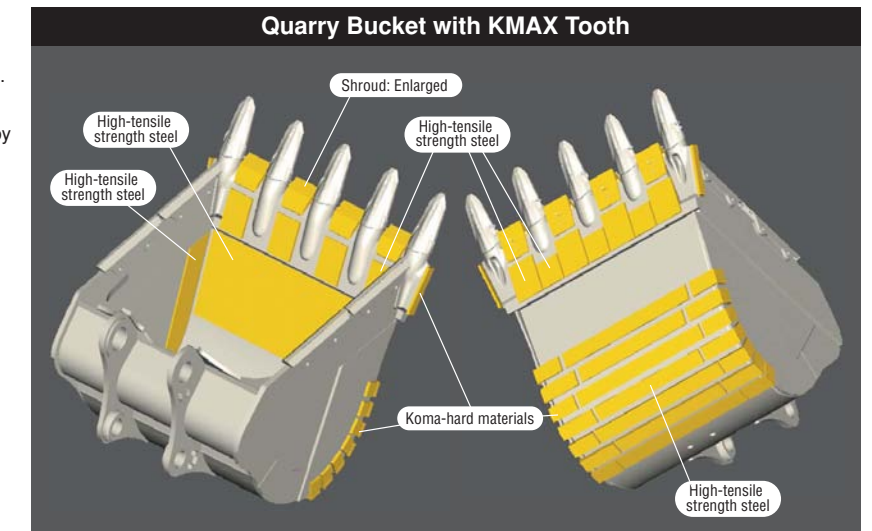

STEP 1

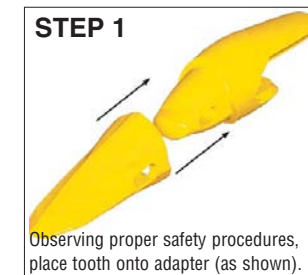

Observing proper safety procedures, place tooth onto adapter (as shown).

STEP 2

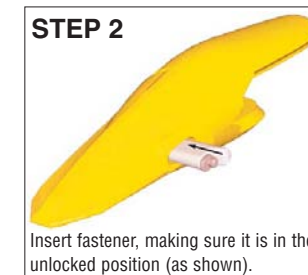

Insert fastener, making sure it is in the unlocked position (as shown).

STEP 3

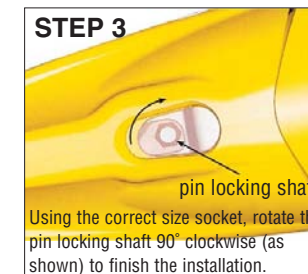

Using the correct size socket, rotate the pin locking shaft 90° clockwise (as shown) to finish the installation.

STEP 4

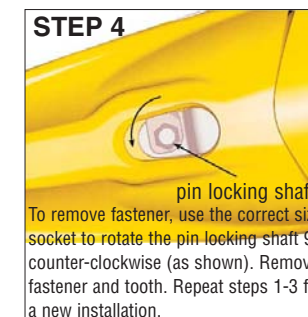

To remove fastener, use the correct size socket to rotate the pin locking shaft 90° counter-clockwise (as shown). Remove fastener and tooth. Repeat steps 1-3 for a new installation.



Photo may include optional equipment.

WORKING ENVIRONMENT

The cab interior is spacious and provides a comfortable working environment...

Large Comfortable Cab

Comfortable Cab

New PC600-8R's cab offers an exceptionally comfortable operating environment. The large cab enables full flat reclining of the seat back with headrest.

Pressurized Cab

The optional air conditioner, air filter and a higher internal air pressure (6.0 mm Aq 0.2" in Aq) prevent external dust from entering the cab.

Low Noise Design

Noise level is remarkably reduced, not only engine noise but also swing and hydraulic relief noise.

Low Vibration with Cab Damper Mounting

PC600-8R uses a new, improved cab damper mount system that incorporates longer stroke and the addition of a spring. The new cab damper mounting combined with a strengthened left and right side deck aids vibration reduction at the operator's seat.

Vibration at floor is reduced from 120 dB (VL) to 115 dB (VL).

dB (VL) is index for expressing size of vibration.

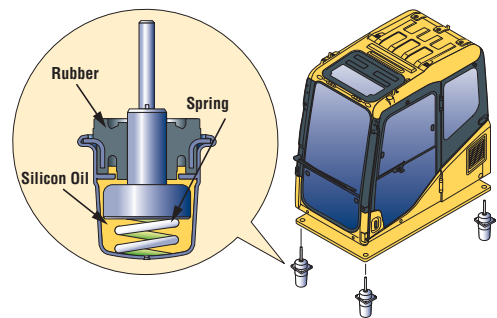

Comparison of Riding Comfort

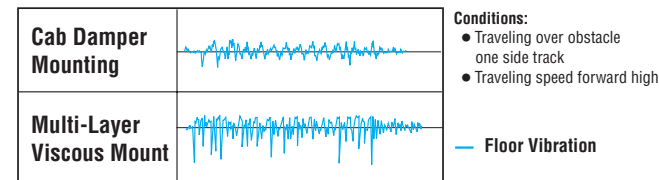

Vertical direction on graph shows size of vibration.



Photo may include optional equipment.

Automatic Air Conditioner (optional)

A 6,900 kcal air conditioner is utilized. The bi-level control function keeps the operator's head and feet cool and warm respectively. This improved air flow function keeps the inside of the cab comfortable throughout the year.

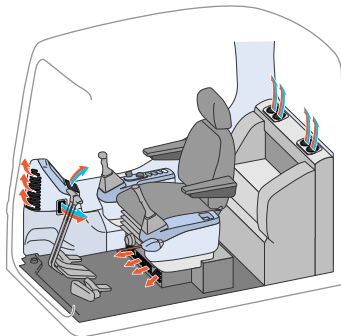

Skylight



Sliding Window

Washable Cab Floor Mat
 The PC600-8R's cab floor mat is easy to keep clean. The gently inclined surface has a flanged floor mat and drainage holes to facilitate runoff.



Seat with headrest reclined full flat

Photo may include optional equipment.

Multi-position Controls

The multi-position, PPC (proportional pressure control) levers allow the operator to work in comfort while maintaining precise control. A double-slide mechanism allows the seat and control levers to move together or independently, allowing the operator to position the controls for maximum productivity and comfort.



Seat Sliding Amount: 340 mm 13.4", increased 120 mm 4.7"



Defroster (optional)



Cab Frame Mounted Wiper



Bottle Holder and Magazine Rack

Safety Features

Cab

OPG top guard level 2 (by ISO 10262) capable with optional bolt-on top guard.

Wide Visibility

The right side window pillar has been removed and the rear pillar reshaped to provide better visibility. Blind spots have been decreased by 34%.

Pump/engine Room Partition

prevents oil from spraying on the engine if a hydraulic hose should burst.

Thermal and Fan Guards are placed around high-temperature parts of the engine and fan drive.

Steps Serrated and Large Handrail

Steps serrated provide anti-slip footing for added safety.



Large Handrail and Wide Catwalk



Anti-slip Plates

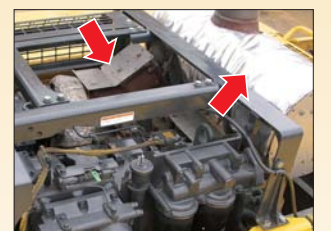

Thermal Guard

EASY MAINTENANCE FEATURES

Komatsu Designed the PC600-8R for Easy Service Access.

Easy Checking and Maintenance of Engine

Engine check points are concentrated on one side of the machine to facilitate daily checks. Thermal guards are placed around high-temperature parts such as turbocharger.



Wide Catwalk and Large Handrails

Easier, safer operator cab access and maintenance checks.



Anti-slip Plates

Spiked plates provided on top of the machine cab maintains anti-slip performance for a prolonged period.

Easy Cleaning of Radiator

Reverse-rotation function of the hydraulic driven fan facilitates cleaning of the cooling unit.



Steps Connected to the Machine Cab

Steps allows access from left hand catwalk to top of machine for engine check and maintenance.



Dust Indicator with 5-step Indication

Informs of air cleaner clogging in 5 steps to warn of filter condition.



Easy Detachable Radiator

Engine hood opens fully to facilitate removal and installation of the radiator. The hood can be opened vertically by changing the position of the torsion bar.

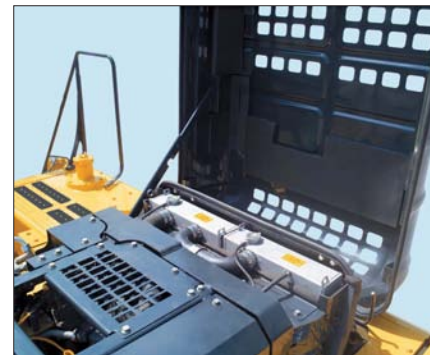

One-touch Drain Cock

Easier, cleaner engine oil changes.

Reduced Maintenance Costs

High performance filters are used in the hydraulic circuit and engine. Longer hydraulic oil, hydraulic oil filter, engine oil and engine oil filter element replacement intervals significantly reduce maintenance costs.



Electric Operated Grease Gun Equipped with Hose Reel (optional)

Greasing is made easy with the electric operated grease gun and indicator.



Indicator Grease gun

Electric Priming Pump

Bleeding air from fuel system is easily accomplished with the electric priming pump.



Electric priming pump switch

High-Quality EMMS Self-diagnostic System



• Abnormality checking function

In case any abnormality should occur, the monitoring system checks whether hydraulic pressure, solenoid ON/OFF status, engine speed, electrical connections, etc. are in the normal conditions to keep the machine downtime to a minimum.

• Maintenance history memory function

Maintenance records such as replacement of engine oil, hydraulic oil, filters, etc. can be stored.

• Trouble data memory function

All the trouble data are stored to serve as references for future trouble-shooting.

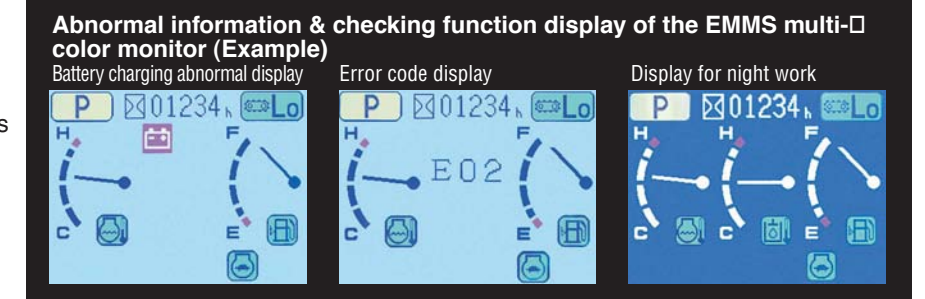
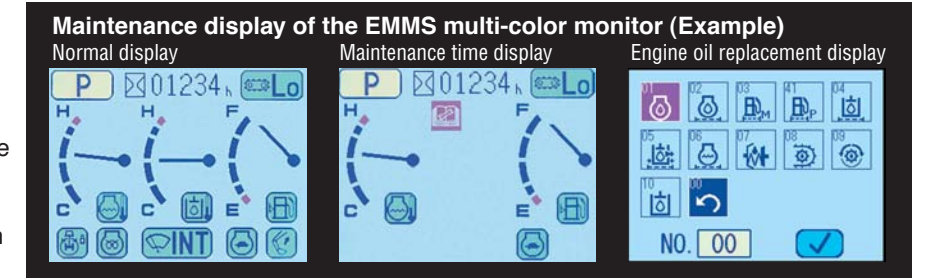

Photo may include optional equipment.

SPECIFICATIONS



ENGINE

Model Komatsu SAA6D140E-5
 Type Water-cooled, 4-cycle, direct injection
 Aspiration Turbocharged, aftercooled
 Number of cylinders 6
 Bore **140 mm** 5.51"
 Stroke **165 mm** 6.50"
 Piston displacement **15.24 ltr** 930 in³
 Governor All-speed, electronic
 Horsepower:
 SAE J1995 Gross **323 kW** 433 HP
 ISO 9249 / SAE J1349* Net **320 kW** 429 HP
 Rated rpm 1800 rpm
 Fan drive type Hydraulic
 *Net horsepower at the maximum speed of radiator cooling fan is 288 kW 386HP.



HYDRAULIC SYSTEM

Type Open-center load-sensing system
 Number of selectable working modes 3
 Main pump:
 Type Variable-capacity piston pumps
 Pumps for Boom, arm, bucket, swing, and travel circuits
 Maximum flow:
 Main **2 x 410 ltr/min** 2 x 108 U.S. gal/min
 Fan drive pump Variable-capacity piston pump
 Sub-pump for control circuit Gear pump
 Hydraulic motors:
 Travel 2 x axial piston motor with parking brake
 Swing 2 x axial piston motor with swing holding brake

Relief valve setting:
 Implement circuits
 Backhoe **31.9 MPa** 325 kgf/cm² 4,620 psi
 Loading shovel **29.4 MPa** 300 kgf/cm² 4,270 psi
 Travel circuit **34.3 MPa** 350 kgf/cm² 4,980 psi
 Swing circuit **25.5 MPa** 260 kgf/cm² 3,700 psi
 Pilot circuit **2.9 MPa** 30 kgf/cm² 430 psi

Hydraulic cylinders:
 Number of cylinders—bore x stroke
 Boom **2 – 185 mm x 1725 mm** 7.3" x 67.9"
 Arm
 Backhoe **1 – 200 mm x 2045 mm** 7.9" x 80.5"
 Loading shovel **2 – 200 mm x 2045 mm** 7.9" x 80.5"
 Bucket : STD **1 – 185 mm x 1425 mm** 7.3" x 56.1"
 for **2.9m** 9.6" Arm. **1 – 185 mm x 1610 mm** 7.3" x 63.4"
 Bucket bottom **2 – 140 mm x 335 mm** 5.5" x 13.2"



DRIVES AND BRAKES

Steering control Two levers with pedals
 Drive method Fully hydrostatic
 Travel motor Axial piston motor, in-shoe design
 Reduction system Planetary triple reduction
 Maximum drawbar pull **415kN** 42300 kg 93,250 lb
 Gradeability 70%
 Maximum travel speed
 Low **3.0 km/h** 1.9 mph
 High **4.9 km/h** 3.0 mph
 Service brake Hydraulic lock
 Parking brake Oil disc brake



SWING SYSTEM

Driven method Hydraulic motor
 Swing reduction Planetary gear
 Swing circle lubrication Grease-bathed
 Swing lock Oil disc brake
 Swing speed 8.3 rpm



UNDERCARRIAGE

Center frame H-leg frame
 Track frame Box-section
 Seal of track Sealed
 Track adjuster Hydraulic
 No. of shoes 49 each side (PC600-8R)
 52 each side (PC600LC-8R)
 No. of carrier rollers 3 each side
 No. of track rollers 8 each side (PC600-8R)
 9 each side (PC600LC-8R)



COOLANT AND LUBRICANT CAPACITY (REFILLING)

Fuel tank **880 ltr** 232.5 U.S. gal
 Radiator **58 ltr** 15.3 U.S. gal
 Engine **40 ltr** 10.6 U.S. gal
 Final drive, each side **10 ltr** 2.6 U.S. gal
 Swing drive **2 x 13 ltr** 2 x 3.4 U.S. gal
 Hydraulic tank **360 ltr** 95.0 U.S. gal



OPERATING WEIGHT (APPROXIMATE)

BACKHOE
 Operating weight, including **7660 mm** 25'2" boom, **3500 mm** 11'6" arm, SAE heaped **2.7 m³** 3.53 yd³ backhoe bucket, operator, lubricant, coolant, full fuel tank, and the standard equipment.

Shoes	PC600-8R		PC600LC-8R	
	Operating Weight	Ground Pressure	Operating Weight	Ground Pressure
Triple grouser 600 mm 24"	57300 kg 126,320 lb	101.6 kPa 1.04 kgf/cm ² 14.8 psi	58300 kg 128,530 lb	96.1 kPa 0.98 kgf/cm ² 13.9 psi
750 mm 29.5"	58100 kg 128,090 lb	82.5 kPa 0.84 kgf/cm ² 11.9 psi	59100 kg 130,290 lb	78.0 kPa 0.80 kgf/cm ² 11.4 psi
900 mm 35.5"	—	—	60000 kg 132,280 lb	65.9 kPa 0.67 kgf/cm ² 9.5 psi

LOADING SHOVEL
 Operating weight, including **4000 mm** 13'1" boom, **3000 mm** 9'10" arm, **4.0 m³** 5.2 yd³ heaped bucket, operator, lubricants, coolant, full fuel tank and standard equipment.

Shoes	PC600-8R		PC600LC-8R	
	Operating Weight	Ground Pressure	Operating Weight	Ground Pressure
Double grouser 600 mm 24"	61300 kg 135,140 lb	109 kPa 1.11 kgf/cm ² 15.8 psi	62300 kg 137,350 lb	102 kPa 1.04 kgf/cm ² 14.8 psi



DIMENSIONS

Boom	7660 mm 25'2"	7660 mm 25'2"	7660 mm 25'2"	7300 mm 23'11"	6600 mm 21'8"
Arm	3500 mm 11'6"	4300 mm 14'1"	5200 mm 17'1"	3500 mm 11'6"	2900 mm 9'6"
A Overall length	12910 mm 42'4"	12830 mm 42'1"	12535 mm 41'2"	12545 mm 41'2"	11930 mm 39'2"
B Overall height (to top of boom)	4300 mm 14'1"	4655 mm 15'3"	5235 mm 17'2"	4280 mm 14'1"	4600 mm 15'1"

	PC600-8R	PC600LC-8R
C Overall width	3900 mm 12'10"	3900 mm 12'10"
D Overall height (to top of cab)	3280 mm 10'9"	3280 mm 10'9"
E Ground clearance, counterweight	1365 mm 4'6"	1365 mm 4'6"
F Ground clearance (minimum)	780 mm 2'7"	780 mm 2'7"
G Tail swing radius	3900 mm 12'10"	3900 mm 12'10"
H Track length on ground	4250 mm 13'11"	4600 mm 15'1"
I Track length	5340 mm 17'6"	5690 mm 18'8"
J Track gauge	2590 mm 8'6"	2590 mm 8'6"
K Track gauge when expanded	3300 mm 10'10"	3300 mm 10'10"
L Width of crawler	3190 mm 10'6"	3190 mm 10'6"
M Width of crawler when expanded	3900 mm 12'10"	3900 mm 12'10"
N Shoe width	600 mm 24"	600 mm 24"
O Grouser height	37 mm 1.5"	37 mm 1.5"
P Machine cab height	3435 mm 11'3"	3435 mm 11'3"
Q Machine cab width	3195 mm 10'6"	3195 mm 10'6"
R Distance, swing center to rear end	3775 mm 12'5"	3775 mm 12'5"

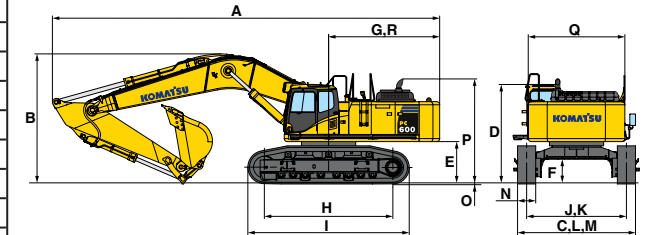

WORKING RANGE

Unit: mm ft in

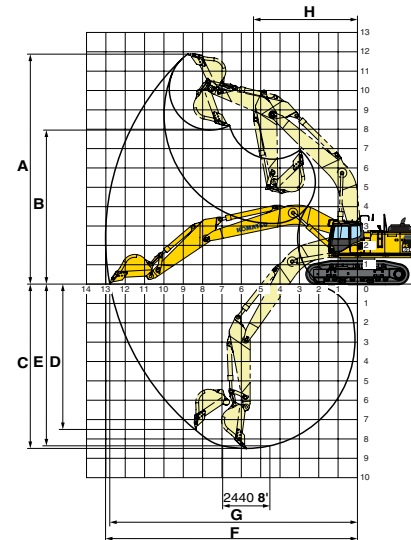

Boom	7660 25'2"	7660 25'2"	7660 25'2"	7300 23'11"	6600 21'8"
Arm	3500 11'6"	4300 14'1"	5200 17'1"	3500 11'6"	2900 9'6"
A Max. digging height	11880 39'0"	12180 40'0"	12560 41'3"	11475 37'8"	11140 36'7"
B Max. dumping height	7960 26'1"	8245 27'1"	8600 28'3"	7650 25'1"	7210 23'8"
C Max. digging depth	8490 27'10"	9275 30'5"	10225 33'7"	8165 26'9"	7060 23'2"
D Max. vertical wall digging depth	7510 24'8"	8375 27'6"	9275 30'5"	6660 21'10"	5630 18'6"
E Max. digging depth of cut for 8' level	8360 27'5"	9175 30'1"	10125 33'3"	8030 26'4"	6910 22'8"
F Max. digging reach at ground level	13020 42'9"	13740 45'1"	14630 48'0"	12615 41'5"	11550 37'11"
G Max. digging reach at ground level	12800 42'0"	13555 44'6"	14435 47'4"	12385 40'8"	11300 37'1"
H Min. swing radius	5370 17'7"	5385 17'8"	5510 18'1"	5090 16'8"	4670 15'4"
Bucket digging force (SAE)	264 kN 26900 kgf 59,300 lb				289 kN 29500 kgf 65,040 lb
Bucket digging force at power max. (SAE)	285 kN 29100 kgf 64,150 lbf				312 kN 31770 kgf 70,040 lb
Arm crowd force (SAE)	222 kN 22600 kgf 49,820 lb	194 kN 19800 kgf 43,650 lb	170 kN 17300 kgf 38,140 lb	222 kN 22600 kgf 49,820 lb	260 kN 26500 kgf 58,420 lb
Arm crowd force at power max (SAE)	238 kN 24300 kgf 53,570 lb	209 kN 21300 kgf 46,960 lb	182 kN 18600 kgf 41,010 lb	238 kN 24300 kgf 53,570 lb	280 kN 28500 kgf 62,830 lb
Bucket digging force (ISO)	294 kN 30000 kgf 66,140 lb				336 kN 34300 kgf 75,620 lb
Bucket digging force at power max. (ISO)	317 kN 32300 kgf 71,210 lb				362 kN 36900 kgf 81,350 lb
Arm crowd force (ISO)	228 kN 23300 kgf 51,370 lb	202 kN 20600 kgf 45,410 lb	176 kN 17900 kgf 39,460 lb	228 kN 23300 kgf 51,370 lb	272 kN 27700 kgf 61,070 lb
Arm crowd force at power max (ISO)	246 kN 25100 kgf 55,340 lb	218 kN 22200 kgf 48,940 lb	189 kN 19300 kgf 42,550 lb	246 kN 25100 kgf 55,340 lb	293 kN 29900 kgf 65,920 lb

BACKHOE BUCKET AND ARM COMBINATION

BUCKET CAPACITY (HEAPED)		WIDTH		WEIGHT (with side cutters) kg lb	TOOTH	ARM LENGTH m ft in							
SAE, PCSA m ³ yd ³	CECE m ³ yd ³	With Side shrouds, Side cutters mm in	Without Side shrouds, Side cutters mm in			3.5 11'6"	4.3 14'1"	5.2 17'1"					
use with 7.66m 25'2" boom													
2.0	2.62	1.8	2.35	1430	56.3"	1250	49.2"	2130	4,700	KMAX	○	○	○
2.3	3.01	2.1	2.75	1580	62.2"	1400	55.1"	2260	4,980	KMAX	○	○	○
2.7	3.53	2.4	3.14	1780	70.1"	1600	63.0"	2430	5,360	KMAX	○	○	○
use with 7.3m 23'11" HD boom													
2.8	3.66	2.5	3.27	1920	75.6"	1920	75.6"	3100	6,830	KMAX	○	○	○
3.1	4.05	2.8	3.66	2040	80.3"	2040	80.3"	3210	7,080	KMAX	○	○	○
use with 6.6m 21'8" SE boom													
3.5	4.58	3.1	4.05	2110	83.1"	2110	83.1"	3280	7,230	KMAX	○	○	○

These charts are based on over-side stability with fully loaded bucket at maximum reach.

○ : General purpose use, density up to 1.8 t/m³ 3,000 lb/yd³ □ : General purpose use, density up to 1.5 t/m³ 2,500 lb/yd³

— : Not useable

* : Bucket lip width ** : Available only to LC crawler

LOADING SHOVEL DIMENSIONS

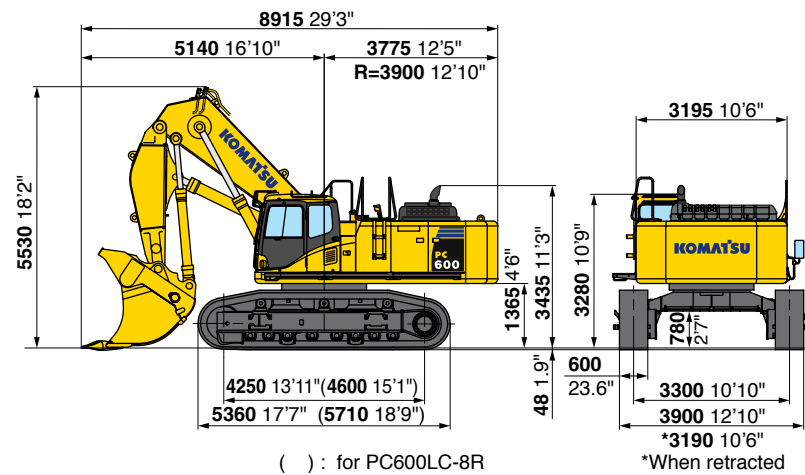

() : for PC600LC-8R

*When retracted

LOADING SHOVEL WORKING RANGE AND BUCKET SELECTION

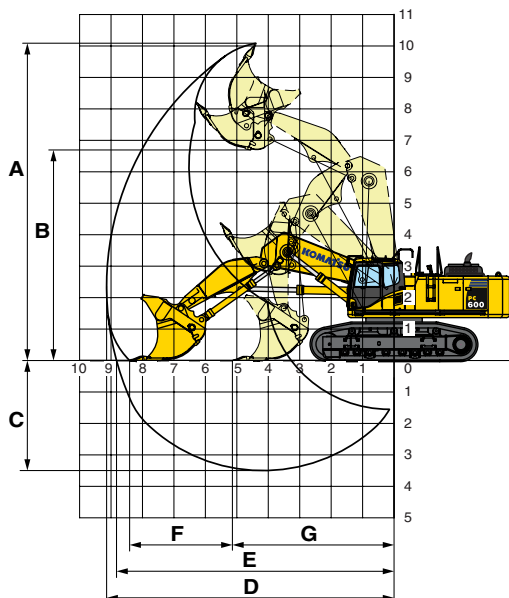

Working Range

Type of bucket	Bottom dump	
Capacity—heap	4.0 m ³	5.2 yd ³
A Max. cutting height	10090 mm	33'1"
B Max. dumping height	6705 mm	22'0"
C Max. digging depth	3495 mm	11'6"
D Max. digging reach	9190 mm	30'2"
E Max. digging reach at ground level	8850 mm	29'0"
F Level crowding distance	3275 mm	10'9"
G Min. crowd distance	5135 mm	16'10"
Bucket digging force	386 kN	39400 kg 86,860 lb
Arm crowd force	338 kN	34500 kg 76,660 lb

Bucket Selection

Type of bucket	Bottom dump	
Capacity—heap	4.0 m ³	5.2 yd ³
Width	2090 mm	82.3"
Weight	5700 kg	12,570 lb
No. of bucket teeth	6	
Recommended uses	General-purpose digging and loading	

LIFTING CAPACITY

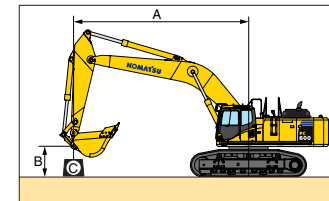

PC600-8R

A: Reach from swing center

B: Bucket hook height

C: Lifting capacity

Cf: Rating over front

Cs: Rating over side

⊙ : Rating at maximum reach

Boom : 7.66m 25'2", Arm : 3.5m 11'6", Bucket : 2.7m³ 3.53cu.yd, Shoes : 600mm 24" triple, L MODE: "OFF" □ □ □ □ unit: kg lb

A/D	MAX		9.1m 30'0"		7.6m 25'0"		6.1m 20'0"		4.6m 15'0"		3.0m 10'	
	Cf	Cs	Cf	Cs	Cf	Cs	Cf	Cs	Cf	Cs	Cf	Cs
9.1m	*6950	*6950										
30'	*15,300	*15,300										
7.6m	*6750	*6750	*9350									
25'	*14,900	*14,900	*20,700	*20,700								
6.1m	*6850	*6850	*9800									
20'	*15,100	*15,100	*21,600	21,400	*24,100	*24,100						
4.6m	*7100	6500	*10450	9300	*12150	*12150	*15000	*15000	*20250	*20250		
15'	*15,600	14,300	*23,100	20,600	*26,800	*26,800	*33,100	*33,100	*44,600	*44,600		
3.0m	*7550	6050	*11200	8900	*13500	12100	*17100	17050				
10'	*16,700	13,400	*24,700	19,600	*29,700	26,700	*37,700	37,600				
1.5m	7950	5900	11250	8500	*14600	11450	*19050	16150	*14050	*14050		
5'	17,600	13,100	24,800	18,700	*32,100	25,200	*42,000	35,600	*31,000	*31,000		
0m	8100	6000	10900	8150	14500	10850	*19850	15450	*16550	*16550		
0'	17,900	13,300	24,100	18,000	32,000	23,900	*43,700	34,100	*36,400	*36,400		
-1.5m	8650	6400	10750	8000	14100	10450	*19650	15200	*22300	*22300	*12250	*12250
-5'	19,100	14,200	23,700	17,700	31,100	23,000	*43,300	33,500	*49,200	*49,200	*27,000	*27,000
-3.0m	9750	7250	10750	8050	14200	10550	*18550	15250	*24150	*24150	*19450	*19450
-10'	21,500	16,000	23,700	17,700	31,300	23,200	*40,900	33,600	*53,300	*53,300	*42,900	*42,900
-4.6m	*10150	8850			*12650	10900	*16300	15550	*20850	*20850	*26900	*26900
-15'	*22,400	19,600			*27,900	24,000	*35,900	34,300	*46,000	*46,000	*59,400	*59,400
-6.1m	*9550	*9550					*11950	*11950	*15700	*15700		
-20'	*21,000	*21,000					*26,300	*26,300	*34,700	*34,700		

Boom : 7.66m 25'2", Arm : 3.5m 11'6", Bucket : 2.7m³ 3.53cu.yd, Shoes : 600mm 24" triple, L MODE: "ON" □ □ □ □ unit: kg lb

A/D	MAX		9.1m 30'0"		7.6m 25'0"		6.1m 20'0"		4.6m 15'0"		3.0m 10'	
	Cf	Cs	Cf	Cs	Cf	Cs	Cf	Cs	Cf	Cs	Cf	Cs
9.1m	*8600	*8600										
30'	*18,900	*18,900										
7.6m	*8350	*8350	*11800	9900								
25'	*18,400	*18,400	*26,100	21,900								
6.1m	*8450	7200	*12350	9700	*13650	13600						
20'	*18,600	15,900	*27,200	21,400	*30,100	30,000						
4.6m	8600	6500	12100	9300	*15200	12900	*18600	*18600	*24900	*24900		
15'	18,900	14,300	26,700	20,600	*33,500	28,400	*41,000	*41,000	*54,900	*54,900		
3.0m	8100	6050	11650	8900	15900	12100	*21300	17050				
10'	17,900	13,400	25,700	19,600	35,000	26,700	*46,900	37,600				
1.5m	7950	5900	11250	8500	15150	11450	21700	16150	*16900	*16900		
5'	17,600	13,100	24,800	18,700	33,400	25,200	47,900	35,600	*37,300	*37,300		
0m	8100	6000	10900	8150	14500	10850	20950	15450	*19800	*19800		
0'	17,900	13,300	24,100	18,000	32,000	23,900	46,200	34,100	*43,600	*43,600		
-1.5m	8650	6400	10750	8000	14100	10450	*26550	24650	*26550	24650	*14750	*14750
-5'	19,100	14,200	23,700	17,700	31,100	23,000	45,600	33,500	*58,500	54,300	*32,600	*32,600
-3.0m	9750	7250	10750	8050	14200	10550	20700	15250	*30150	24950	*23200	*23200
-10'	21,500	16,000	23,700	17,700	31,300	23,200	45,700	33,600	*66,500	55,000	*51,200	*51,200
-4.6m	11800	8850			14550	10900	*20550	15550	*26200	25550	*33300	*33300
-15'	26,100	19,600			32,100	24,000	*45,300	34,300	*57,800	56,300	*73,400	*73,400
-6.1m	*12400	*12400					*15400	*15400	*20100	*20100		
-20'	*27,300	*27,300					*34,000	*34,000	*44,300	*44,300		

Boom : 7.3m 23'11", Arm : 3.5m 11'6", Bucket : 2.8m³ 3.66cu.yd, Shoes : 600mm 24" triple, L MODE: "OFF" □ □ □ □ unit: kg lb

A/D	MAX		9.1m 30'0"		7.6m 25'0"		6.1m 20'0"		4.6m 15'0"		3.0m 10'	
	Cf	Cs	Cf	Cs	Cf	Cs	Cf	Cs	Cf	Cs	Cf	Cs
9.1m	*6500	*6500										
30'	*14,400	*14,400										
7.6m	*6300	*6300	*7700	*7700								
25'	*13,900	*13,900	*17,000	*17,000								
6.1m	*6350	*6350	*9650	9300	*10700	*10700						
20'	*14,000	*14,000	*21,300	20,600	*23,600	*23,600						
4.6m	*6650	6650	*10250	9000	*11900	*11900	*14550	*14550				
15'	*14,700	14,600	*22,700	19,900	*26,200	*26,200	*32,100	*32,100				
3.0m	*7150	6200	*11000	8600	*13200	11950	*16900	*16900	*24200	*24200		
10'	*15,800	13,600	*24,200	19,000	*29,100	26,300	*37,200	*37,200	*53,300	*53,300		
1.5m	*7950	6050	11000	8200	*14300	11250	*18700	16200	*20750	*20750		
5'	*17,600	13,300	24,200	18,100	*31,500	24,800	*41,300	35,700	*45,800	*45,800		
0m	8400	6150	10700	7950	14500	10750	*19600	15400	*21300	*21300		
0'	18,500	13,600	23,600	17,500	31,900	23,800	*43,200	34,000	*47,000	*47,000		
-1.5m	9000	6650	10500	7800	14150	10450	*19450	15100	*26400	24650	*14350	*14350
-5'	19,900	14,600	23,200	17,100	31,200	23,100	*42,900	33,300	*58,200	54,300	*31,700	*31,700
-3.0m	10300	7600	10550	7850	*14100	10500	*18250	15150	*24150	*24150	*21900	*21900
-10'	22,700	16,800	23,300	17,300	*31,800	23,200	*40,300	33,400	*53,300	*53,300	*48,300	*48,300
-4.6m	*10350	9600			*11850	10750	*15750	15450	*20500	*20500	*26950	*26950
-15'	*22,800	21,200			*26,100	23,700	*34,700	34,100	*45,200	*45,200	*59,400	*59,400
-6.1m	*9500	*9500					*10800	*10800	*14500	*14500		

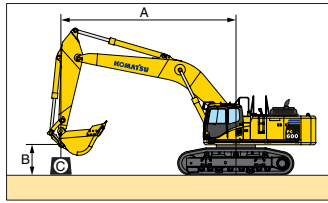

PC600-8R

- A: Reach from swing center
- B: Bucket hook height
- C: Lifting capacity
- Cf: Rating over front
- Cs: Rating over side
- ☉: Rating at maximum reach

Boom : 7.3m 23'11", Arm : 3.5m 11'6", Bucket : 2.8m³ 3.66cu.yd, Shoes : 600mm 24" triple, L MODE: "ON" unit: kg lb

B	A	MAX		9.1m 30'		7.6m 25'		6.1m 20'		4.6m 15'		3.0m 10'	
		Cf	Cs	Cf	Cs	Cf	Cs	Cf	Cs	Cf	Cs	Cf	Cs
9.1m 30'		*8150	*8150										
	30'	*18,000	*18,000										
7.6m 25'		*7900	*7900	*9550	9450								
	25'	*17,400	*17,400	*21,100	20,800								
6.1m 20'		*7950	7450	12150	9300	*13450	13350						
	20'	*17,600	16,500	26,800	20,600	*29,600	29,400						
4.6m 15'		*8300	6650	11800	9000	*14950	12700	*18050	*18050				
	15'	*18,300	14,600	26,000	19,900	*32,900	28,000	*39,800	*39,800				
3.0m 10'		8350	6200	11400	8600	15700	11950	*21000	17400	*29850	27900		
	10'	18,400	13,600	25,100	19,000	34,700	26,300	*46,300	38,300	*65,800	61,500		
1.5m 5'		8200	6050	11000	8200	15000	11250	21800	16200	*24850	*24850		
	5'	18,100	13,300	24,200	18,100	33,100	24,800	48,000	35,700	*54,700	*54,700		
0m 0'		8400	6150	10700	7950	14500	10750	20950	15400	*25450	24800		
	0'	18,500	13,600	23,600	17,500	31,900	23,800	46,200	34,000	*56,100	54,700		
-1.5m -5'		9000	6650	10500	7800	14150	10450	20600	15100	*32000	24650	*17300	*17300
	-5'	19,900	14,600	23,200	17,100	31,200	23,100	45,400	33,300	*70,500	54,300	*38,200	*38,200
-3.0m -10'		10300	7600	10550	7850	14200	10500	20650	15150	*30200	24900	*26150	*26150
	-10'	22,700	16,800	23,300	17,300	31,300	23,200	45,500	33,400	*66,500	54,900	*57,600	*57,600
-4.6m -15'		12900	9600			14450	10750	*19900	15450	*25800	25550	*33950	*33950
	-15'	28,400	21,200			31,900	23,700	*43,900	34,100	*56,900	56,300	*74,800	*74,800
-6.1m -20'		*12450	*12450					*14050	*14050	*18650	*18650		
	-20'	*27,400	*27,400					*30,900	*30,900	*41,200	*41,200		

Boom : 6.6m 21'8", Arm : 2.9m 9'6", Bucket : 3.5m³ 4.58cu.yd, Shoes : 600mm 24" triple, L MODE: "OFF" unit: kg lb

B	A	MAX		9.1m 30'		7.6m 25'		6.1m 20'		4.6m 15'		3.0m 10'	
		Cf	Cs	Cf	Cs	Cf	Cs	Cf	Cs	Cf	Cs	Cf	Cs
9.1m 30'		*9700	*9700										
	30'	*21,400	*21,400										
7.6m 25'		*9050	*9050			*11550	*11550						
	25'	*20,000	*20,000			*25,400	*25,400						
6.1m 20'		*8950	*8950			*11950	*11950						
	20'	*19,700	*19,700			*26,400	*26,400						
4.6m 15'		*9200	8200	*11350	8900	*12900	12700	*15500	*15500	*20300	*20300		
	15'	*20,300	18,100	*25,000	19,600	*28,500	28,000	*34,200	*34,200	*44,800	*44,800		
3.0m 10'		*9800	7600	11400	8600	*14000	12000	*17650	17600	*24700	*24700		
	10'	*21,600	16,800	25,100	18,900	*30,900	26,500	*38,900	38,800	*54,500	*54,500		
1.5m 5'		9950	7400	11050	8300	*14900	11400	*19000	16050	*27350	26200		
	5'	22,000	16,400	24,400	18,300	*32,900	25,100	*41,800	35,400	*60,300	57,700		
0m 0'		10300	7650	10850	8050	14700	10950	*19900	15700	*27600	25250		
	0'	22,700	16,900	23,900	17,800	32,400	24,200	*43,900	34,600	*60,800	55,700		
-1.5m -5'		11300	8400			14500	10800	*19350	15450	*26100	25100	*19300	*19300
	-5'	24,900	18,500			32,000	23,800	*42,700	34,000	*57,500	55,400	*42,600	*42,600
-3.0m -10'		*11500	10050			*12850	10900	*16800	14950	*22950	*22950	*30500	*30500
	-10'	*25,400	22,100			*28,400	24,100	*37,100	33,000	*50,600	*50,600	*67,200	*67,200
-4.6m -15'		*10650	*10650			*12900	*12900	*17500	*17500	*23000	*23000		
	-15'	*23,500	*23,500			*28,500	*28,500	*38,500	*38,500	*49,100	*49,100		

Boom : 6.6m 21'8", Arm : 2.9m 9'6", Bucket : 3.5m³ 4.58cu.yd, Shoes : 600mm 24" triple, L MODE: "ON" unit: kg lb

B	A	MAX		9.1m 30'		7.6m 25'		6.1m 20'		4.6m 15'		3.0m 10'	
		Cf	Cs	Cf	Cs	Cf	Cs	Cf	Cs	Cf	Cs	Cf	Cs
9.1m 30'		*11850	*11850										
	30'	*26,100	*26,100										
7.6m 25'		*11100	*11100			*14400	13400						
	25'	*24,500	*24,500			*31,800	29,600						
6.1m 20'		*10950	9400			*14950	13200						
	20'	*24,200	20,700			*32,900	29,100						
4.6m 15'		10850	8200	11700	8900	*16150	12700	*19200	18950	*24900	*24900		
	15'	24,000	18,100	25,800	19,600	*35,600	28,000	*42,300	41,700	*54,800	*54,800		
3.0m 10'		10150	7600	11400	8600	15800	12000	*21850	17600	*30400	28400		
	10'	22,400	16,800	25,100	18,900	34,900	26,500	*48,200	38,800	*67,100	62,700		
1.5m 5'		9950	7400	11050	8300	15150	11400	*21700	16050	*33750	26200		
	5'	22,000	16,400	24,400	18,300	33,400	25,100	47,800	35,400	*74,400	57,700		
0m 0'		10300	7650	10850	8050	14700	10950	21300	15700	*34200	25250		
	0'	22,700	16,900	23,900	17,800	32,400	24,200	46,900	34,600	*75,300	55,700		
-1.5m -5'		11300	8400			14500	10800	21000	15450	*32450	25100	*23100	*23100
	-5'	24,900	18,500			32,000	23,800	46,300	34,000	*71,500	55,400	*50,900	*50,900
-3.0m -10'		13450	10050			14650	10900	20450	14950	*28700	25500	*36700	*36700
	-10'	29,600	22,100			32,300	24,100	45,100	33,000	*63,300	56,200	*80,900	*80,900
-4.6m -15'		*13800	13750					*16550	16150	*22200	*22200	*28350	*28350
	-15'	*30,400	30,400					*36,500	35,600	*48,900	*48,900	*62,600	*62,600

*Load is limited by hydraulic capacity rather than tipping. Ratings are based on SAE standard NO. J1097. Rated loads do not exceed 87% of hydraulic lift capacity or 75% of tipping load.

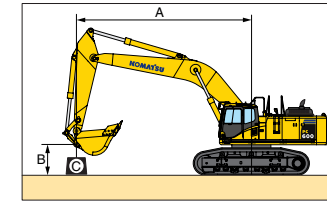

PC600LC-8R

- A: Reach from swing center
- B: Bucket hook height
- C: Lifting capacity
- Cf: Rating over front
- Cs: Rating over side
- ☉: Rating at maximum reach

Boom : 7.66m 25'2", Arm : 3.5m 11'6", Bucket : 2.7m³ 3.53cu.yd, Shoes : 600mm 24" triple, L MODE: "OFF" unit: kg lb

B	A	MAX		9.1m 30'		7.6m 25'		6.1m 20'		4.6m 15'		3.0m 10'	
		Cf	Cs	Cf	Cs	Cf	Cs	Cf	Cs	Cf	Cs	Cf	Cs
9.1m 30'		*6950	*6950										
	30'	*15,300	*15,300										
7.6m 25'		*6750	*6750	*9350	*9350								
	25'	*14,900	*14,900	*20,700	*20,700								
6.1m 20'		*6850	*6850	*9800	*9800	*10950	*10950						
	20'	*15,100	*15,100	*21,600	*21,600	*24,100	*24,100						
4.6m 15'		*7100	6600	*10450	9500	*12150	*12150	*15000	*15000	*20250	*20250		
	15'	*15,600	14,600	*23,100	20,900	*26,800	*26,800	*33,100	*33,100	*44,600	*44,600		
3.0m 10'		*7550	6200	*11200	9050	*13500	12350	*17100	*17100				
	10'	*16,700	13,700	*24,700	20,000	*29,700	27,200	*37,700	*37,700				
1.5m 5'		*8300	6050	*11850	8650	*14600	11650	*19050	16450	*24050	*24050		
	5'	*18,300	13,400	*26,200	19,100	*32,100	25,700	*42,000	36,300	*53,000	*53,000		
0m 0'		9350	6150	*12250	8350	*15100	11050	*19850	15750	*26550	*26550		
	0'	20,600	13,600	*27,000	18,400	*33,300	24,400	*43,700	34,800	*56,400	*56,400		
-1.5m -5'		9950	6550	*12150	8200	*15000	10650	*19650	15500	*22300	*22300	*12250	*12250
	-5'	22,000	14,500	*26,800	18,100	*33,100	23,500	*43,300	34,100	*49,200	*49,		

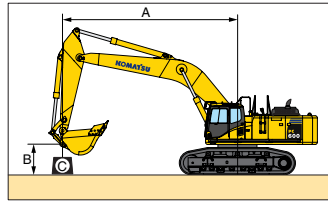

PC600LC-8R

- A: Reach from swing center
- B: Bucket hook height
- C: Lifting capacity
- Cf: Rating over front
- Cs: Rating over side
- ☉: Rating at maximum reach

Boom : 7.3m 23'11", Arm : 3.5m 11'6", Bucket : 2.8m³ 3.66cu.yd, Shoes : 600mm 24" triple, L MODE: "ON" unit: kg lb

B	A	MAX		9.1m 30'		7.6m 25'		6.1m 20'		4.6m 15'		3.0m 10'	
		Cf	Cs	Cf	Cs	Cf	Cs	Cf	Cs	Cf	Cs	Cf	Cs
9.1m 30'		*8150	*8150										
		*18,000	*18,000										
7.6m 25'		*7900	*7900	*9550	*9550								
		*17,400	*17,400	*21,100	*21,100								
6.1m 20'		*7950	7650	*12250	9500	*13450	*13450						
		*17,600	16,800	*27,000	20,900	*29,600	*29,600						
4.6m 15'		*8300	6800	*13050	9200	*14950	12900	*18050	*18050				
		*18,300	15,000	*28,700	20,200	*32,900	28,500	*39,800	*39,800				
3.0m 10'		*8900	6350	13050	8800	*16550	12150	*21000	17700	*29850	28350		
		*19,600	14,000	28,800	19,400	*36,500	26,800	*46,300	39,000	*65,800	62,500		
1.5m 5'		9450	6150	12650	8400	17250	11500	*23300	16500	*24850	*24850		
		20,900	13,600	27,900	18,500	38,000	25,300	*51,400	36,300	*54,700	*54,700		
0m 0'		9700	6300	12300	8100	16700	11000	24400	15700	*25450	25250		
		21,400	13,900	27,200	17,900	36,800	24,200	53,800	34,700	*56,100	55,700		
-1.5m -5'		10400	6800	12150	7950	16350	10700	24000	15400	*32000	25100	*17300	*17300
		23,000	15,000	26,800	17,500	36,100	23,600	53,000	34,000	*70,500	55,400	*38,200	*38,200
-3.0m -10'		11900	7800	12200	8000	16400	10700	*22950	15450	*30200	25400	*26150	*26150
		26,200	17,200	26,900	17,600	36,200	23,600	*50,600	34,000	*66,500	56,000	*57,600	*57,600
-4.6m -15'		*13350	9800			*15150	11000	*19900	15750	*25800	*25800	*33950	*33950
		*29,400	21,600			*33,400	24,200	*43,900	34,800	*56,900	*56,900	*74,800	*74,800
-6.1m -20'		*12450	*12450					*14050	*14050	*18650	*18650		
		*27,400	*27,400					*30,900	*30,900	*41,200	*41,200		

Boom : 6.6m 21'8", Arm : 2.9m 9'6", Bucket : 3.5m³ 4.58cu.yd, Shoes : 600mm 24" triple, L MODE: "OFF" unit: kg lb

B	A	MAX		9.1m 30'		7.6m 25'		6.1m 20'		4.6m 15'		3.0m 10'	
		Cf	Cs	Cf	Cs	Cf	Cs	Cf	Cs	Cf	Cs	Cf	Cs
9.1m 30'		*9700	*9700										
		*21,400	*21,400										
7.6m 25'		*9050	*9050			*11550	*11550						
		*20,000	*20,000			*25,400	*25,400						
6.1m 20'		*8950	*8950			*11950	*11950						
		*19,700	*19,700			*26,400	*26,400						
4.6m 15'		*9200	8400	*11350	9050	*12900	12900	*15500	*15500	*20300	*20300		
		*20,300	18,500	*25,000	20,000	*28,500	28,400	*34,200	*34,200	*44,800	*44,800		
3.0m 10'		*9800	7750	*11800	8750	*14000	12250	*17650	*17650	*24700	*24700		
		*21,600	17,100	*26,000	19,300	*30,900	27,000	*38,900	*38,900	*54,500	*54,500		
1.5m 5'		*10800	7600	*12150	8450	*14900	11600	*19000	16350	*27350	26650		
		*23,800	16,700	*26,800	18,700	*32,900	25,600	*41,800	36,100	*60,300	58,800		
0m 0'		*11500	7800	*12100	8250	*15300	11200	*19900	16000	*27600	25700		
		*25,400	17,200	*26,700	18,200	*33,700	24,700	*43,900	35,300	*60,800	56,700		
-1.5m -5'		*11600	8600			*14800	11000	*19350	15750	*26100	25600	*19300	*19300
		*25,600	18,900			*32,600	24,200	*42,700	34,700	*57,500	56,400	*42,600	*42,600
-3.0m -10'		*11500	10250			*12850	11150	*16800	15250	*22950	*22950	*30500	*30500
		*25,400	22,600			*28,400	24,600	*37,100	33,600	*50,600	*50,600	*67,200	*67,200
-4.6m -15'		*10650	*10650					*12900	*12900	*17500	*17500	*22300	*22300
		*23,500	*23,500					*28,500	*28,500	*38,500	*38,500	*49,100	*49,100

Boom : 6.6m 21'8", Arm : 2.9m 9'6", Bucket : 3.5m³ 4.58cu.yd, Shoes : 600mm 24" triple, L MODE: "ON" unit: kg lb

B	A	MAX		9.1m 30'		7.6m 25'		6.1m 20'		4.6m 15'		3.0m 10'	
		Cf	Cs	Cf	Cs	Cf	Cs	Cf	Cs	Cf	Cs	Cf	Cs
9.1m 30'		*11850	*11850										
		*26,100	*26,100										
7.6m 25'		*11100	*11100			*14400	13650						
		*24,500	24,500			*31,800	30,100						
6.1m 20'		*10950	9550			*14950	13450						
		*24,200	21,100			*32,900	29,600						
4.6m 15'		*11250	8400	13350	9050	*16150	12900	*19200	*19200	*24900	*24900		
		*24,800	18,500	29,500	20,000	*35,600	28,400	*42,300	*42,300	*54,800	*54,800		
3.0m 10'		11650	7750	13050	8750	*17500	12250	*21850	17850	*30400	28900		
		25,700	17,100	28,800	19,300	*38,600	27,000	*48,200	39,400	*67,100	63,700		
1.5m 5'		11450	7600	12700	8450	17400	11600	*23650	16350	*33750	26650		
		25,300	16,700	28,100	18,700	38,400	25,600	*52,100	36,100	*74,400	58,800		
0m 0'		11850	7800	12500	8250	16950	11200	24750	16000	*34200	25700		
		26,100	17,200	27,600	18,200	37,300	24,700	54,500	35,300	*75,300	56,700		
-1.5m -5'		13000	8600			16750	11000	*24200	15750	*32450	25600	*23100	*23100
		28,700	18,900			36,900	24,200	*53,300	34,700	*71,500	56,400	*50,900	*50,900
-3.0m -10'		*14700	10250			*16350	11150	*21300	15250	*28700	25950	*36700	*36700
		*32,500	22,600			*36,100	24,600	*46,900	33,600	*63,300	57,300	*80,900	*80,900
-4.6m -15'		*13800	*13800					*16550	16450	*22200	*22200	*28350	*28350
		*30,400	*30,400					*36,500	36,300	*48,900	*48,900	*62,600	*62,600

*Load is limited by hydraulic capacity rather than tipping. Ratings are based on SAE standard NO. J1097. Rated loads do not exceed 87% of hydraulic lift capacity or 75% of tipping load.

Transportation specifications (length x height x width)

Backhoe

Specs shown include the following equipment:
 PC600-8R : Boom 7660 mm 25'2", Arm 3500 mm 11'6",
 Bucket 2.7 m³ 3.53 yd³, Shoes 600 mm 24" triple grouser

3 Kits Transportation

Work equipment assembly (Backhoe)
 Weight : 12.2 t 13.5 U.S.ton

Boom
 4.8t : 7920 x 2040 x 1190
 5.3U.S.ton : 26'0" x 6'8" x 3'11"

Arm
 3.3t : 4870 x 1210 x 480
 3.6U.S.ton : 16'0" x 4'0" x 1'7"

Bucket
 2.4t : 2150 x 1780 x 1780
 2.6U.S.ton : 7'1" x 5'10" x 5'10"

Boom cylinder & Arm cylinder
 Total 1.7 t 1.9 U.S.ton

4 Kits Transportation

Work equipment assembly (Backhoe)
 Weight : 12.2 t 13.5 U.S.ton

Boom
 4.8t : 7920 x 2040 x 1190
 5.3U.S.ton : 26'0" x 6'8" x 3'11"

Arm
 3.3t : 4870 x 1210 x 480
 3.6U.S.ton : 16'0" x 4'0" x 1'7"

Bucket
 2.4t : 2150 x 1780 x 1780
 2.6U.S.ton : 7'1" x 5'10" x 5'10"

Boom cylinder & Arm cylinder
 Total 1.7 t 1.9 U.S.ton

Loading Shovel

Specs shown include the following equipment:
 PC600-8R : Boom 4000 mm 13'1", Arm 3000 mm 9'10",
 Bucket 4.0 m³ 5.2 yd³, Shoes 600 mm 24" double grouser

3 Kits Transportation

Work equipment assembly (Loading shovel)
 Width : 2090 6'10"
 Weight : 16.2t 17.9U.S.ton

Boom
 4.8t : 7920 x 2040 x 1190
 5.3U.S.ton : 26'0" x 6'8" x 3'11"

Arm
 3.3t : 4870 x 1210 x 480
 3.6U.S.ton : 16'0" x 4'0" x 1'7"

Bucket
 2.4t : 2150 x 1780 x 1780
 2.6U.S.ton : 7'1" x 5'10" x 5'10"

Boom cylinder & Arm cylinder
 Total 1.7 t 1.9 U.S.ton

Base machine

3470 11'5"
 PC600-8R 6270 20'7"
 PC600LC-8R 6440 21'2"
 Width : 3195 10'6"
 Weight : PC600-8R 34.1t 37.6U.S.ton
 PC600LC-8R 35.1t 38.7U.S.ton

Upper structure

5070 16'8"
 2660 8'9"
 Width : 3195 10'6"
 Weight : 17.8t 19.6U.S.ton

Undercarriage

875 2'10"
 1260 4'2"
 PC600-8R 5340 17'6"
 PC600LC-8R 5690 18'8"
 Weight : PC600-8R 16.3t [8.15t x 2] 18U.S.ton [9U.S.ton x 2]
 PC600LC-8R 17.3t [8.65t x 2] 19.1U.S.ton [9.5U.S.ton x 2]

Base machine

3480 11'5"
 PC600-8R 6270 20'7"
 PC600LC-8R 6440 21'2"
 Width : 3195 10'6"
 Weight : PC600-8R 34.1t 37.6U.S.ton
 PC600LC-8R 35.1t 38.7U.S.ton

Others

Weight : 11.0t 12.1U.S.ton

780 2'7"
 3195 10'6"
 1330 4'4"

1910 6'3"
 500 1'8"
 2310 7'7"
 500 1'8"

Weight : 10.75t 11.8U.S.ton

Others

Weight : 11.0t 12.1U.S.ton

780 2'7"
 3195 10'6"
 1330 4'4"

1910 6'3"
 500 1'8"
 2310 7'7"
 500 1'8"

Weight : 10.75t 11.8U.S.ton

Others

Weight : 11.0t 12.1U.S.ton

780 2'7"
 3195 10'6"
 1330 4'4"

1910 6'3"
 500 1'8"
 2310 7'7"
 500 1'8"

Weight : 10.75t 11.8U.S.ton