

KOMATSU®

PC350HD-8

NET HORSEPOWER

184 kW **246 HP** @ 1950 rpm

OPERATING WEIGHT

38694–40266 kg

85,305–88,771 lb

BUCKET CAPACITY

0.68–1.96 m³ **0.89–2.56 yd³**

**PC
350
HD**



Photo may include optional equipment.

HYDRAULIC EXCAVATOR

WALK-AROUND

Productivity Features

● **High Production and Low Fuel Consumption**

Powerful working performance and fuel efficiency increase production and lower fuel costs.

● **Large Drawbar Pull**

provides excellent steering and slope climbing performance.

● **Higher Lifting Capacity**

Lifting mode is provided for increased lifting operation.

● **Large Digging Force**

Pressing the Power Max function button temporarily increases digging force by 8%.

● **Multi-Function Color Monitor**

- Working mode selection
- Self-diagnostic with EMMS
- Attachment hydraulic oil flow adjustment in cab

● **Automatic Three Speed Travel**

● **General Features**

- Operator Protective Guard (OPG) top guard Level 2 capable
- Engine neutral start with lock lever
- New cab design for hydraulic excavators
- Slip-resistant plates for improved foot grip
- Pattern change valve is standard

KOMTRAX®

KOMTRAX equipped machines can send location, SMR and operation maps to a secure website utilizing wireless technology. Machines also relay error codes, cautions, maintenance items, fuel levels, and much more.



Easy Maintenance

- Extended replacement interval of engine oil, engine oil filter, and hydraulic filter
- Equipped with 10 micron fuel pre-filter as standard (with water separator)
- Side-by-side cooling concept enables individual cooling modules to be serviced
- Equipped with the EMMS monitoring system
- Easy access to engine oil filter and fuel drain valve
- Large fuel tank capacity
- Equipped with KOMTRAX® (standard)

PC350HD-8 Unique Features

- Large lift capacity
- Excellent stability
- Extremely low ground pressure
- Wide track gauge 2740 mm **9'0"**
- Rugged undercarriage (PC450LC-8 components)

NET HORSEPOWER
184 kW **246 HP** @ 1950 rpm

OPERATING WEIGHT
38694 – 40266 kg
85,305 – 88,771 lb

BUCKET CAPACITY
0.68 – 1.96 m³
0.89 – 2.56 yd³

Ecology and Economy Features

- Low emission engine
- A powerful turbocharged and air-to-air aftercooled Komatsu SAA6D114E-3 engine provides 184 kW **246 HP** (net). This engine is EPA Tier 3 and EU stage 3A emissions certified, without sacrificing power or machine productivity.
- Economy mode reduces fuel consumption
- Low operation noise

Large Comfortable Cab

- Low-noise cab design
- Low vibration with cab damper mounting
- Highly pressurized cab with automatic air conditioner
- Operator seat and console with armrests enables adjustment to the proper operational position

Large TFT LCD Monitor

- Large, easy-to-use, 7" multi-color monitor
- Can be displayed in ten languages for global support

TFT: Thin Film Transistor
LCD: Liquid Crystal Display



Photo may include optional equipment.

Excellent Reliability and Durability

- High rigidity work equipment
- Heavy duty boom assembly
- Sturdy frame structure
- Reliable Komatsu manufactured major components
- Highly reliable electronic devices

PRODUCTIVITY FEATURES



Komatsu's new "ecot3" engines are designed to deliver optimum performance under the toughest of conditions, while meeting the latest environmental regulations. This engine is EPA Tier 3, EU Stage 3A, and Japan emissions certified; "ecot3" – ecology and economy combined with Komatsu technology to create a high performance engine without sacrificing power or productivity.

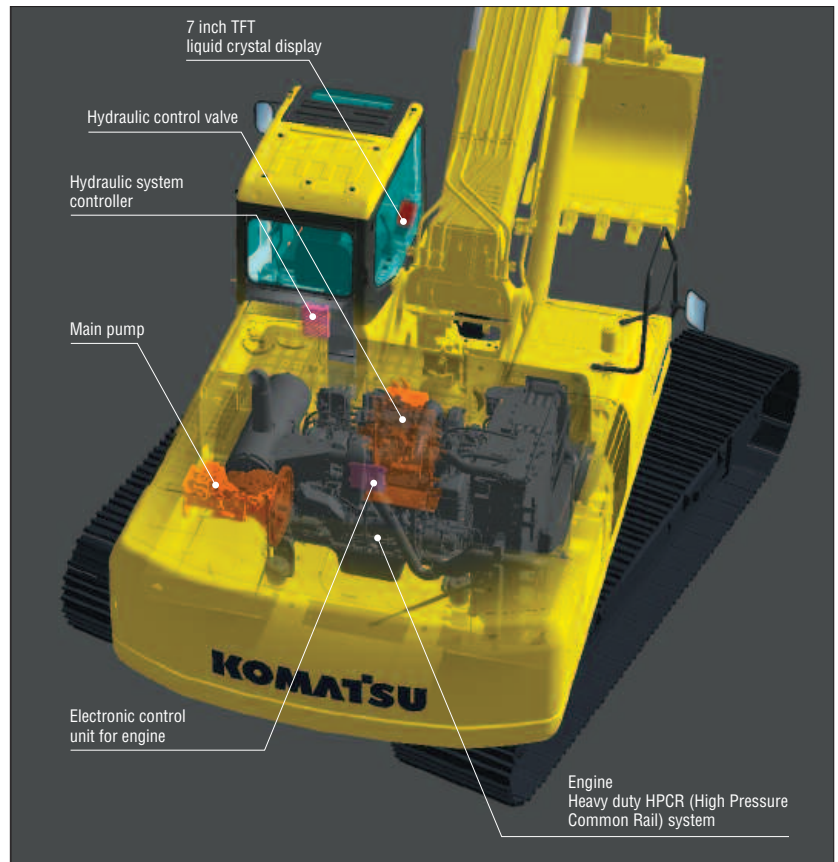

Environment-Friendly Clean Engine

The PC350HD-8 gets its exceptional power and work capacity from a Komatsu SAA6D114E-3 engine. Net output is 184 kW **246 HP**, providing increased hydraulic power and improved fuel efficiency.

Komatsu SAA6D114E-3 is EPA Tier 3 and EU stage 3A emissions certified with NOx emission reduced by 33%. The SAA6D114E-3 engine adopts the electronically controlled Heavy Duty HPCR* fuel injection system.

*HPCR: High Pressure Common Rail

Hydraulics

Unique two-pump system ensures smooth compound movement of the work equipment. HydrauMind controls both pumps for efficient engine power use. This system also reduces hydraulic loss during operation.



Large Maximum Drawbar Pull

Large maximum drawbar pull provides superb steering and slope climbing performance (25% up over PC350LC-8).

Maximum drawbar pull: 329 kN 33510 kgf **73,880 lb**

Large Digging Force

With the one-touch Power Max function, digging force is further increased (8.5 seconds of operation).

Maximum arm crowd force (ISO):

160 kN (16.3t) ➔ **171 kN (17.4t)** **7% UP**
(with Power Max)

Maximum bucket digging force (ISO):

212 kN (21.6t) ➔ **227 kN (23.1t)** **7% UP**
(with Power Max)

*Measured with Power Max function, 3185 mm 10'5" arm and ISO rating

Smooth Loading Operation

Two return hoses improve hydraulic performance. In the arm out function, a portion of the oil is returned directly to the tank for smooth operation.



Two Boom Settings

Smooth mode provides easy operation for fine work or scraping down operation. When maximum digging force is needed, switch to Power mode for more effective excavating.

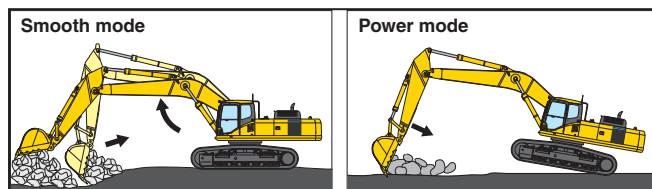

Boom floats upward, reducing lifting of machine front. This facilitates fine work and scraping down operations.

Boom force is at maximum for normal production digging.

Automatic Three-Travel Speed

Travel speed is automatically shifted from high to low speed according to the pressure demand on the travel circuit.

Working Mode Selection

The PC350HD-8 excavator is equipped with five working modes (P, E, L, B, and ATT mode). Each mode is designed to match engine speed, pump flow, and system pressure with the current application. This provides the flexibility to match equipment performance to the job at hand.

Working Mode	Application	Advantage
P	Power mode	<ul style="list-style-type: none"> Maximum production/power Fast cycle times
E	Economy mode	<ul style="list-style-type: none"> Excellent fuel economy
L	Lifting mode	<ul style="list-style-type: none"> Hydraulic pressure is increased by 7%
B	Breaker mode	<ul style="list-style-type: none"> Optimum engine rpm, hydraulic flow, 1-way
ATT	Attachment mode	<ul style="list-style-type: none"> Optimum engine rpm, hydraulic flow, 2-way

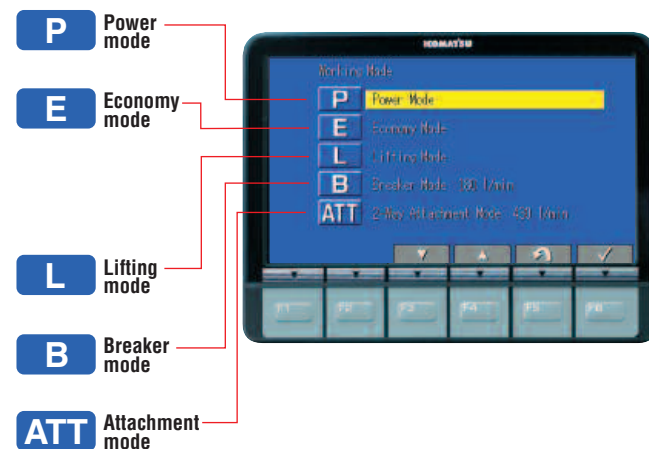

Power/Economy Modes

The PC350HD-8 offers two operator selectable working modes. Power mode for severe or high production applications. Economy mode allows significant fuel savings at slightly reduced production levels.

Lifting Mode

When the lifting mode is selected, lifting capacity is increased 7% by raising hydraulic pressure.

WORKING ENVIRONMENT



Low Noise Cab

The newly-designed cab is highly rigid and has excellent sound absorption ability. Through improvement of noise source reduction and use of a low noise engine, hydraulic equipment, and air conditioner, this machine generates a low level of noise similar to that of a modern automobile.

Low Vibration with Cab Damper Mounting

PC350HD-8 uses a multi-layer viscous mount system that incorporates a longer stroke and the addition of a spring. The new cab damper mounting combined with a high rigidity deck aids vibration reduction at the operator seat.

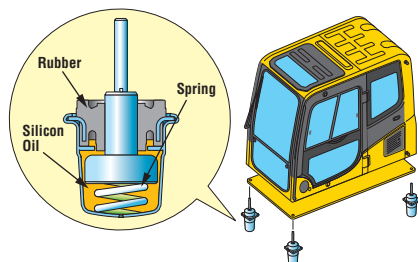

Wide Newly-Designed Cab

Newly-designed wide spacious cab includes a high-back seat with reclining backrest. The seat height and longitudinal inclination are easily adjusted using a pull-up lever. You can set the appropriate operational posture of the armrest together with the console. Reclining the seat further enables you to place it into the fully flat state with the headrest attached.



Pressurized Cab

Automatic air conditioner, air filter, and a higher internal air pressure (+6.0 mm Aq +0.2" Aq) help minimize external dust from entering the cab.

Automatic Air Conditioner

Enables you to easily and precisely set cab atmosphere with the simple touch pad controls on the large LCD. The bi-level control function improves air flow and keeps the operator comfortable throughout the year. Defroster function keeps cab glass clear.



GENERAL FEATURES

New Cab Design for Hydraulic Excavators

The cab is designed specifically for hydraulic excavators and gains reinforced strength from the pipe-structured cab framework. The cab framework provides high durability and impact resistance with very high impact absorbency.

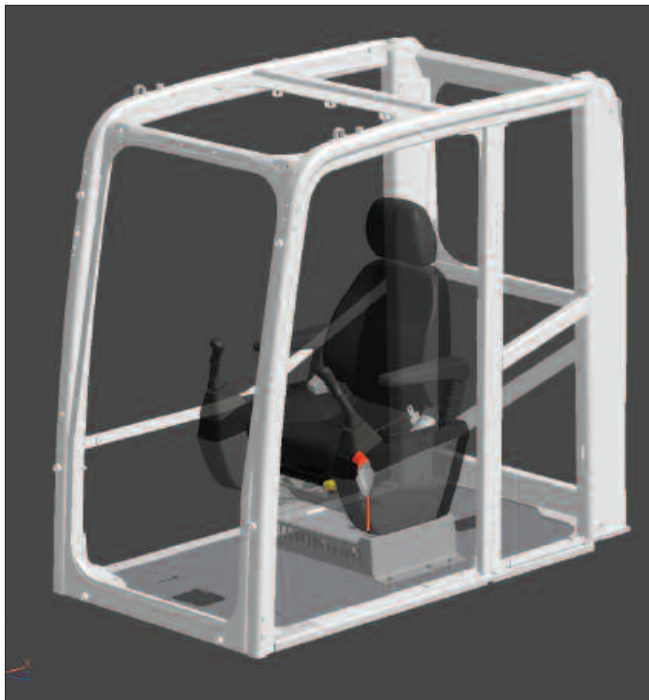

Slip-Resistant Plates

Highly durable slip-resistant plates maintain excellent foot traction performance for the long term.

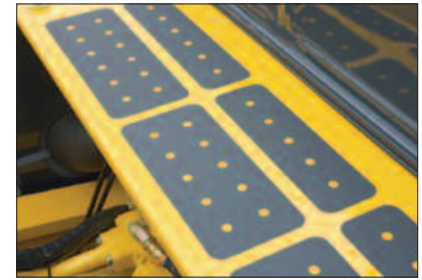

Lock Lever

Makes all hydraulic cab controls inoperable when placed in lock position. Neutral start function allows the machine to be started only in the lock position.



Lock Lever in Lock Position

Large Side-View Mirrors

Large left-side mirror with the addition of right side mirrors allow the operator to see both sides of the machine.



Operator Protective Guard (OPG) Level 2 Top Guard (optional)

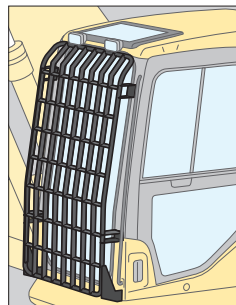

Front Full Guard Level 2 (optional)

Thermal and Fan Guards

Guarding is placed around high-temperature parts of the engine and fan drive.

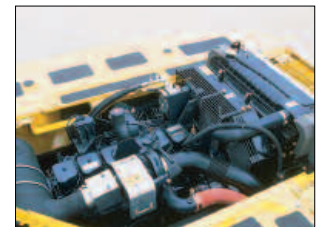

Increased Cab Glass Area

Highly rigid cab allows for increased glass area and provides wide visibility of the work area.

Skylight

Skylight can be opened to improve overhead visibility.



Large Serrated Steps



Hand Rail

MAINTENANCE FEATURES

Self-Diagnostic Monitor

The PC350HD-8 features the most advanced diagnostics system in the industry. The Komatsu-exclusive system identifies maintenance items, reduces diagnostic times, indicates oil and filter replacement hours, and displays error codes.

Continuous Machine Monitoring System

When the starting switch is turned ON, check-before-starting items and caution items appear on the LCD. If abnormalities are found, a warning lamp blinks and a warning buzzer sounds. The continuous machine condition checks help prevent the development of serious problems and allow the operator to concentrate on the work at hand.

Easy Maintenance

Komatsu designed the PC350HD-8 to have easy service access. We know by doing this, routine maintenance and servicing are more likely to be performed, which can mean a reduction in costly downtime later on. Here are some of the many service features found on the PC350HD-8.

Easy Radiator Cleaning

Since the radiator and oil cooler are side-by-side modules, it is easy to clean, remove, and install them.

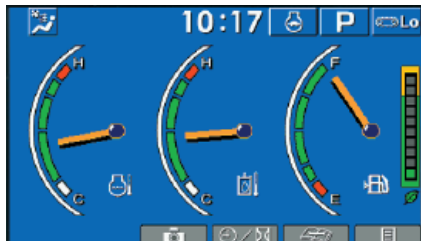

Normal display



Error code display

Abnormalities Display with Code

When an abnormality occurs during operation, a user code is displayed. When an important user code is displayed, a caution lamp blinks and a warning buzzer sounds to alert the operator to take action.

Easy Access to Engine Oil filter and Fuel Drain Valve

Engine oil level check, oil fill port, and fuel filter are one side mounted to improve accessibility. Engine oil filter and fuel drain valve are remotely mounted to improve accessibility.



Maintenance List	Interval	Parain
Engine Oil Change	500 h	499 h
Eng Oil Filter Change	500 h	499 h
Fuel Main Filter Change	1000 h	999 h
Fuel Pre Filter Change	500 h	499 h
Hyd Oil Filter Change	1000 h	999 h
Hyd Oil Breather Change	500 h	499 h

Maintenance time display

Oil Maintenance Function

When the machine exceeds the oil or filter replacement time, the oil maintenance monitor will display lights to inform the operator.

Trouble Data Memory Function

The monitor stores a record of abnormalities for effective troubleshooting.



Engine Oil Filter



Fuel Drain Valve

Equipped with Fuel Pre-Filter (with Water Separator)

Removes water and contaminants in the fuel to help prevent fuel problems.



Equipped with the Eco-Drain Valve as Standard

Enables easier and cleaner engine oil changes.

Maintenance Cost Reduction

Extended Replacement Intervals for Hydraulic Oil and Filter/Engine Oil and Filter

High performance filters are used in the hydraulic circuit and engine. By increasing the hydraulic oil, hydraulic oil filter, engine oil, and engine oil filter replacement intervals, maintenance costs are significantly reduced.

Engine oil & Engine oil filter	every 500 hours
Hydraulic oil	every 5000 hours
Hydraulic oil filter	every 1000 hours

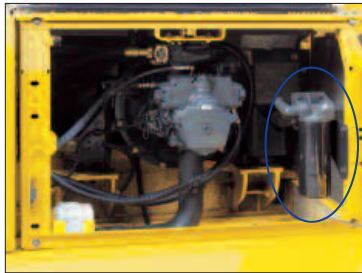

Remote Engine Oil Filter

High-Capacity Air Cleaner

High capacity air cleaner is comparable to that of larger machines. The large air cleaner extends filter element life and service intervals.



High-Pressure In-Line Filter

The PC350HD-8 has high pressure in-line filters installed at the pump discharge ports. This provides an additional level of hydraulic system protection.

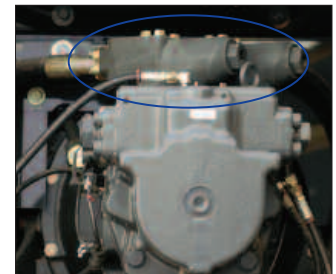

Extended Work Equipment Greasing Interval

High quality BMRC bushings and resin shims are installed in the work equipment, excluding the bucket, which can extend the greasing interval to 500 hours.



RELIABILITY AND FEATURES

High Rigidity Work Equipment

Thanks to large cross-sectional structures, thick high tensile strength steel, and partition walls, the boom and arm exhibit excellent durability and are highly resistant to bending and torsional stress. An HD boom assembly is offered for increased strength and reliability.

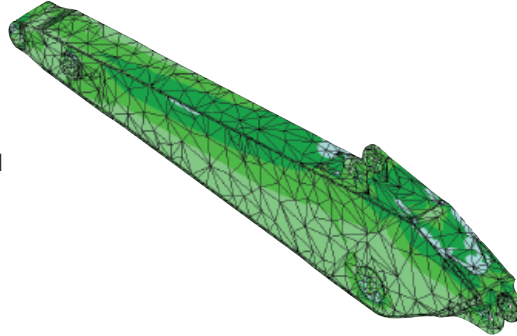

Sturdy Frame Structure

The revolving frame, center frame, and undercarriage are designed using the most advanced three-dimensional CAD and FEM analysis technology.

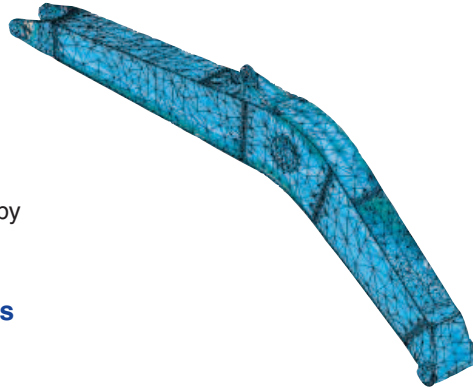

Reliable Components

All of the major machine components, such as engine, hydraulic pumps, hydraulic motors, and control valves are exclusively designed and manufactured by Komatsu.

Highly Reliable Electronic Devices

Exclusively designed electronic devices have passed severe testing.

- Controllers
- Sensors
- Connectors
- Wiring

Metal guard rings protect all the hydraulic cylinders and improve reliability.

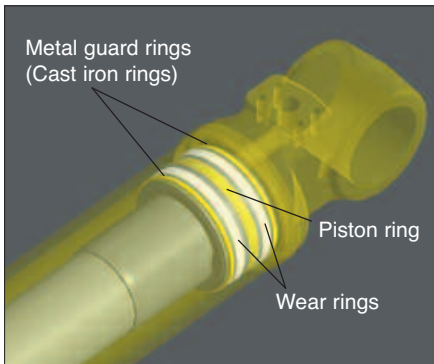

DT-Type Electrical Connectors

DT-type connectors seal tight and have higher reliability.

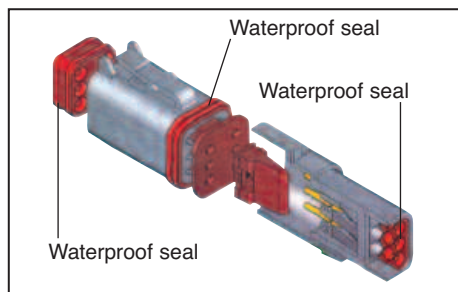

O-Ring Face Seal

Hydraulic hoses are equipped with O-ring seals versus conventional taper seal, to provide extended leak-free life.

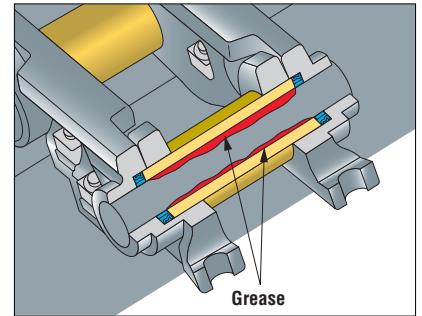

Grease Sealed Track

PC350HD-8 uses grease sealed tracks for extended undercarriage life.



Track Link with Strut

PC350HD-8 uses track links with strut providing superb durability.

Large LCD Color Monitor

Large Multi-Lingual LCD Monitor

A large user-friendly color monitor enables accurate and smooth work. Improved screen visibility is achieved by use of a TFT liquid crystal display that can easily be read at various angles and lighting conditions. All switches are simple and easy to operate. Industry-first function keys facilitate multi-function operations. Displays data in 10 languages to globally support operators around the world.

Indicators

- | | |
|----------------------------------|-----------------------------------|
| 1 Auto-decelerator | 5 Hydraulic oil temperature gauge |
| 2 Working mode | 6 Fuel gauge |
| 3 Travel speed | 7 Eco-gauge |
| 4 Engine water temperature gauge | 8 Function switches menu |

Basic operation switches

- | | |
|-------------------------|---------------------|
| 1 Auto-decelerator | 4 Buzzer cancel |
| 2 Working mode selector | 5 Wiper |
| 3 Travel speed selector | 6 Windshield washer |



Rearview Camera Display

On the large LCD color monitor, the operator can access and view one standard video camera that will display areas directly behind the machine. An optional 2 camera system is available.



Equipment Management Monitoring System (EMMS)

Monitor Function

Controller monitors engine oil level, coolant temperature, battery charge, air filter clogging, etc. If the controller finds any abnormality, it is displayed on the LCD.



PC350HD-8 HYDRAULIC EXCAVATOR

SPECIFICATIONS



ENGINE

Model Komatsu SAA6D114E-3
 Type Water-cooled, 4-cycle, direct injection
 Aspiration Turbocharged and aftercooled
 Number of cylinders 6
 Bore 114 mm **4.49"**
 Stroke 135 mm **5.31"**
 Piston displacement 8.27 ltr **505 in³**
 Horsepower
 SAE J1995 Gross 194 kW **260 HP**
 ISO 9249/SAE J1349 Net 184 kW **246 HP**
 Rated rpm 1950 rpm
 Fan drive type Mechanical
 Governor All-speed, electronic
 EPA Tier 3 and EU stage 3A emissions certified.



HYDRAULIC SYSTEM

Type HydraMind (Hydraulic Mechanical Intelligence New Design) system, closed-center system with load sensing valves and pressure compensated valves
 Number of selectable working modes 5
 Main pump:
 Type Variable displacement piston type
 Pumps for Boom, arm, bucket, swing, and travel circuits
 Maximum flow 535 ltr/min **141 U.S. gal/min**
 Supply for control circuit Self-reducing valve
 Hydraulic motors:
 Travel 2 x axial piston motors with parking brake
 Swing 1 x axial piston motor with swing holding brake
 Relief valve setting:
 Implement circuits 37.3 MPa 380 kg/cm² **5,400 psi**
 Travel circuit 37.3 MPa 380 kg/cm² **5,400 psi**
 Swing circuit 27.9 MPa 285 kg/cm² **4,050 psi**
 Pilot circuit 3.2 MPa 33 kg/cm² **470 psi**

Hydraulic cylinders:
 Number of cylinders—bore x stroke x rod diameter
 Boom 2 – 140 mm x 1480 mm x 100 mm **5.5" x 58.3" x 3.9"**
 Arm 1 – 160 mm x 1825 mm x 110 mm **6.3" x 71.9" x 4.3"**
 Bucket for 3.2 m **10'5"** and 4.0 m **13'2"** Arms
 1-140 mm x 1285 mm x 100 mm **5.5" x 50.6" x 3.9"**
 for 2.54 m **8'4"** Arm
 1-150 mm x 1285 mm x 110 mm **5.9" x 50.6" x 4.3"**



DRIVES AND BRAKES

Steering control Two levers with pedals
 Drive method Hydrostatic
 Maximum drawbar pull 329 kN 33510 kg **73,880 lb**
 Gradeability 70%, 35°
 Maximum travel speed: High 5.5 km/h **3.4 mph**
 (Auto-shift) Mid 4.4 km/h **2.7 mph**
 Low 3.0 km/h **1.9 mph**
 Service brake Hydraulic lock
 Parking brake Mechanical disc brake



SWING SYSTEM

Drive method Hydrostatic
 Swing reduction Planetary gear
 Swing circle lubrication Grease bathed
 Service brake Hydraulic lock
 Holding brake/Swing lock Mechanical disc brake
 Swing speed 9.5 rpm
 Swing torque 11386 kg·m **82,313 ft. lbs.**



UNDERCARRIAGE

Center frame X-frame
 Track frame Box-section
 Track type Sealed
 Track adjuster Hydraulic
 No. of shoes 49 each side
 No. of carrier rollers 2 each side
 No. of track rollers 8 each side



COOLANT AND LUBRICANT CAPACITY (REFILLING)

Fuel tank 605 ltr **160 U.S. gal**
 Coolant 30.3 ltr **8.0 U.S. gal**
 Engine 35.0 ltr **9.2 U.S. gal**
 Final drive, each side 12.0 ltr **3.2 U.S. gal**
 Swing drive 13.4 ltr **3.5 U.S. gal**
 Hydraulic tank 188 ltr **49.7 U.S. gal**



OPERATING WEIGHT (APPROXIMATE)

Operating weight, including 6500 mm **21'3"** one-piece boom, 3185 mm **10'5"** arm, SAE heaped 1.96 m³ **2.56 yd³** bucket, rated capacity of lubricants, coolant, full fuel tank, operator, and standard equipment.

Triple-Grouser Shoes	Operating Weight	Ground Pressure
700 mm 28"	39057 kg 86,105 lb	0.58 kg/cm ² 8.22 psi
800 mm 31.5"	39537 kg 87,214 lb	0.51 kg/cm ² 7.29 psi
900 mm 35.5"	39997 kg 88,178 lb	0.46 kg/cm ² 6.55 psi



WORKING FORCES

	Arm	2540 mm 8'4"	3185 mm 10'5"	4020 mm 13'2"
SAE rating	Bucket digging force at power max.	23300 kgf 51,370 lb	20400 kgf 44,970 lb	20400 kgf 44,970 lb
	Arm crowd force at power max.	19700 kgf 43,430 lb	16800 kgf 37,040 lb	14200 kgf 31,310 lb
ISO rating	Bucket digging force at power max.	26400 kgf 58,200 lb	23100 kgf 50,930 lb	23100 kgf 50,930 lb
	Arm crowd force at power max.	20500 kgf 45,190 lb	17400 kgf 38,360 lb	14700 kgf 32,410 lb



DIMENSIONS

	Arm Length	2540 mm 8'4"	3185 mm 10'5"	4020 mm 13'2"
A	Overall length	11130 mm 36'6"	11170 mm 36'8"	11230 mm 36'10"
B	Length on ground (transport):	6801 mm 22'4"	7528 mm 24'8"	5516 mm 18'1"
C	Overall height (to top of boom)	3244 mm 10'8"	3421 mm 11'3"	3690 mm 12'1"
D	Overall width	3640 mm 11'11"		
E	Overall height (to top of cab)	3200 mm 10'6"		
F	Ground clearance, counterweight	1320 mm 4'4"		
G	Ground clearance (minimum)	550 mm 1'10"		
H	Tail swing radius	3450 mm 11'4"		
I	Track length on ground	4350 mm 14'3"		
J	Track length	5355 mm 17'7"		
K	Track gauge	2740 mm 9'0"		
L	Width of crawler	3640 mm 11'11"		
M	Shoe width	900 mm 35.5"		
N	Grouser height	37 mm 1'5"		
O	Machine cab height	2688 mm 8'10"		
P	Machine cab width	2995 mm 9'10"		
Q	Distance, swing center to rear end	3405 mm 11'2"		

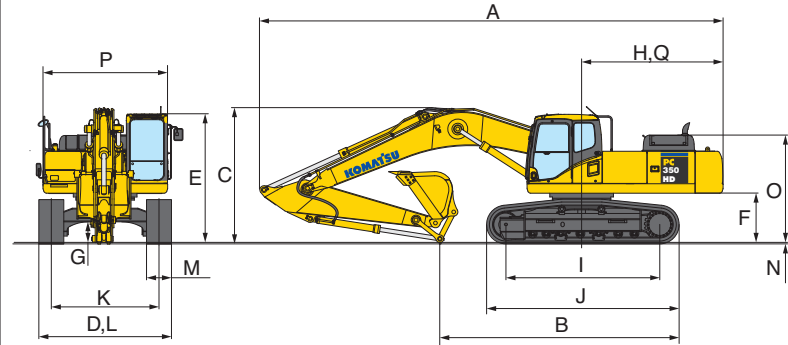

BACKHOE BUCKET, ARM, AND BOOM COMBINATION

Bucket Type	Bucket			Arms		
	Capacity	Width	Weight	2540 mm 8'4"	3185 mm 10'5"	4020 mm 13'2"
Komatsu TL	0.93 m ³ 1.21 yd³	762 mm 30"	1097 kg 2,418 lb	V	V	V
	1.18 m ³ 1.54 yd³	914 mm 36"	1198 kg 2,641 lb	V	V	V
	1.44 m ³ 1.88 yd³	1067 mm 42"	1325 kg 2,921 lb	V	V	V
	1.70 m ³ 2.22 yd³	1219 mm 48"	1426 kg 3,144 lb	V	V	W
	1.96 m ³ 2.56 yd³	1372 mm 54"	1554 kg 3,425 lb	W	W	X
Komatsu HP	0.68 m ³ 0.89 yd³	610 mm 24"	1022 kg 2,254 lb	V	V	V
	0.93 m ³ 1.21 yd³	762 mm 30"	1178 kg 2,598 lb	V	V	V
	1.18 m ³ 1.54 yd³	914 mm 36"	1358 kg 2,993 lb	V	V	V
	1.44 m ³ 1.88 yd³	1067 mm 42"	1439 kg 3,173 lb	V	V	V
	1.70 m ³ 2.22 yd³	1219 mm 48"	1555 kg 3,429 lb	V	V	X
Komatsu HPS	0.68 m ³ 0.89 yd³	610 mm 24"	1112 kg 2,451 lb	V	V	V
	0.93 m ³ 1.21 yd³	762 mm 30"	1294 kg 2,853 lb	V	V	V
	1.18 m ³ 1.54 yd³	914 mm 36"	1437 kg 3,167 lb	V	V	V
	1.44 m ³ 1.88 yd³	1067 mm 42"	1607 kg 3,543 lb	V	V	W
	1.70 m ³ 2.22 yd³	1219 mm 48"	1750 kg 3,857 lb	V	W	X
Komatsu HPX	0.68 m ³ 0.89 yd³	610 mm 24"	1239 kg 2,731 lb	V	V	V
	0.93 m ³ 1.21 yd³	762 mm 30"	1421 kg 3,133 lb	V	V	V
	1.18 m ³ 1.54 yd³	914 mm 36"	1564 kg 3,447 lb	V	V	V
	1.44 m ³ 1.88 yd³	1067 mm 42"	1734 kg 3,823 lb	V	V	W
	1.70 m ³ 2.22 yd³	1219 mm 48"	1877 kg 4,137 lb	V	W	X
	1.96 m ³ 2.56 yd³	1372 mm 54"	2048 kg 4,516 lb	X	X	Y

V – Used with densities up to 3,500 lb/yd³, W – Used with densities up to 3,000 lb/yd³
 X – Used with densities up to 2,500 lb/yd³, Y – Used with densities up to 2,000 lb/yd³, Z – Not useable

WORKING RANGES



WORKING RANGE

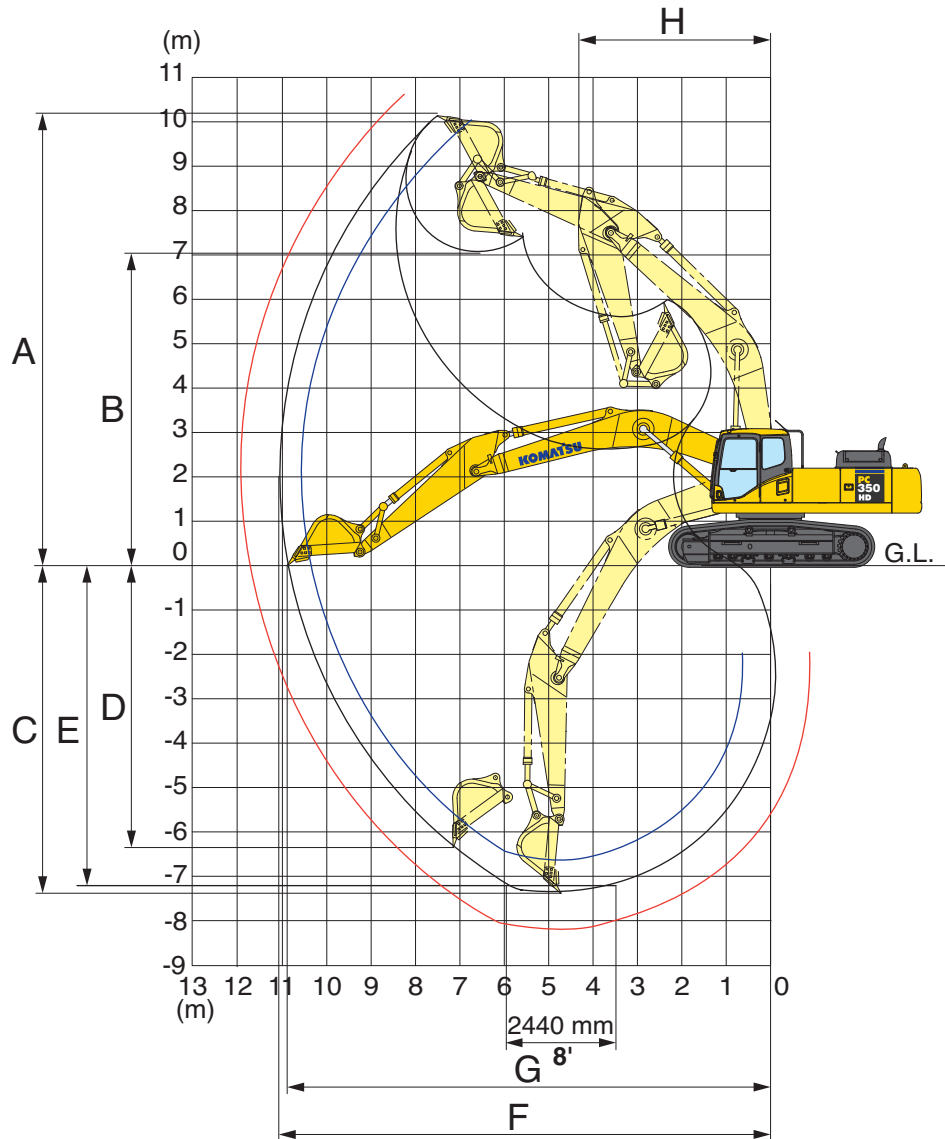

	Arm	2540 mm 8'4"	3185 mm 10'5"	4020 mm 13'2"
A	Max. digging height	10070 mm 33'4"	10260 mm 33'7"	10660 mm 35'0"
B	Max. dumping height	7005 mm 23'0"	7155 mm 23'6"	7600 mm 24'11"
C	Max. digging depth	6640 mm 21'9"	7265 mm 23'10"	8100 mm 26'7"
D	Max. vertical wall digging depth	5795 mm 19'0"	6235 mm 20'6"	7145 mm 23'5"
E	Max. digging depth of cut for 8' level	6455 mm 21'2"	7100 mm 23'3"	7975 mm 26'2"
F	Max. digging reach	10550 mm 34'7"	11100 mm 36'5"	11895 mm 39'0"
G	Max. digging reach at ground level	10315 mm 33'10"	10870 mm 35'8"	11705 mm 38'5"
H	Min. swing radius	4460 mm 14'8"	4310 mm 14'2"	4210 mm 13'10"

LIFTING CAPACITIES



LIFTING CAPACITY

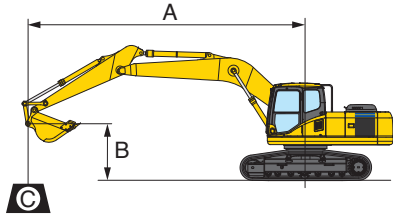

- A: Reach from swing center
- B: Bucket hook height
- C: Lifting capacity
- Cf: Rating over front
- Cs: Rating over side
- : Rating at maximum reach

Conditions:

- Arm: 3185 mm 10'5"
- Boom length 6500 mm 21'3"
- Bucket 1.40 m³ 1.83 yd³ (SAE heaped)
- Bucket weight: 1021 kg 2,252 lb.
- Lifting mode: On

PC350HD-8		Shoe: 700 mm 28"										Unit: kg/lb		
A	B	MAX	3.0 m 10'		4.6 m 15'		6.1 m 20'		7.6 m 25'		9.1 m 30'		MAX	
			Cf	Cs	Cf	Cs	Cf	Cs	Cf	Cs	Cf	Cs	Cf	Cs
7.6 m 25'	7.9 m 26'								*6350 *14,000	*6350 *14,000			*5300 *11,750	*5300 *11,750
6.1 m 20'	8.7 m 29'								*7350 *16,200	*7350 *16,200			*5250 *11,600	*5250 *11,600
4.6 m 15'	9.3 m 30'					*9150 *20,250	*9150 *20,250	*7900 *17,400	7500 16,550	*6250 *13,850	5500 12,150	*5400 *11,900	5350 11,800	
3.0 m 10'	9.6 m 31'			*14350 *31,650	*14350 *31,650	*10500 *23,250	10200 22,500	*8550 *18,900	7200 15,950	*7400 *16,300	5350 11,850	*5750 *12,650	4950 11,000	
1.5 m 5'	9.6 m 31'			*16400 *36,150	14850 32,700	*11650 *25,750	9650 21,350	*9,200 *20,250	6950 15,300	*7650 *16,900	5200 11,550	*6300 *13,950	4850 10,700	
0 m 0'	9.3 m 31'	*8850 *19,600	*8850 *19,600	*17000 *37,450	14350 31,650	*12250 *27,050	9350 20,600	*9500 *21,000	6750 14,850	*7650 *16,950	5100 11,300	*7250 *16,000	4950 10,950	
-1.5 m -5'	8.8 m 29'	*14200 *31,350	*14200 *31,350	*16350 *36,100	14200 31,350	*12100 *26,750	9150 20,250	*9350 *20,650	6650 14,650			*7600 *16,800	5350 11,800	
-3.0 m -10'	8.0 m 26'	*19950 *44,050	*19950 *44,050	*14700 *32,450	14350 31,600	*11100 *24,500	9200 20,300	*8400 *18,500	6650 14,700			*7700 *16,950	6200 13,700	
-4.6 m -15'	6.8 m 22'	*15300 *33,700	*15300 *33,700	*11700 *25,850	*11700 *25,850	*8750 *19,350	*8750 *19,350					*7450 *16,450	*7450 *16,450	
-6.1 m -20'														

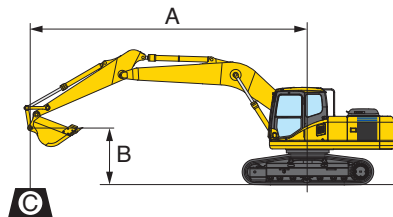

- A: Reach from swing center
- B: Bucket hook height
- C: Lifting capacity
- Cf: Rating over front
- Cs: Rating over side
- : Rating at maximum reach

Conditions:

- Arm: 4020 mm 13'2"
- Boom length 6500 mm 21'3"
- Bucket 1.40 m³ 1.83 yd³ (SAE heaped)
- Bucket weight: 1021 kg 2,252 lb.
- Lifting mode: On

PC350HD-8		Shoe: 700 mm 28"										Unit: kg/lb		
A	B	MAX	3.0 m 10'		4.6 m 15'		6.1 m 20'		7.6 m 25'		9.1 m 30'		MAX	
			Cf	Cs	Cf	Cs	Cf	Cs	Cf	Cs	Cf	Cs	Cf	Cs
7.6 m 25'	8.9 m 29'												*4000 *8,850	*4000 *8,850
6.1 m 20'	9.6 m 32'									*5650 *12,450	*5650 *12,450	*3950 *8,700	*3950 *8,700	
4.6 m 15'	10.1 m 33'							*7050 *15,600	*7050 *15,600	*6450 *14,200	5500 12,200	*4000 *8,850	*4000 *8,850	
3.0 m 10'	10.4 m 34'	*20150 *44,500	*20150 *44,500	*12550 *27,700	*12550 *27,700	*9450 *20,900	*9450 *20,900	*7850 *17,300	7250 16,000	*6800 *15,050	5350 11,800	*4200 *9,300	*4200 *9,300	
1.5 m 5'	10.4 m 34'	*8400 *18,500	*8400 *18,500	*15100 *33,300	15000 33,150	*10850 *12,800	9700 21,400	*8600 *18,950	6900 15,250	*7200 *15,950	5150 11,400	*4550 *10,050	4150 9,150	
0 m 0'	10.2 m 33'	*9250 *20,400	*9250 *20,400	*16450 *36,250	14250 31,400	*11750 *25,900	9250 20,400	*9100 *20,150	6600 14,600	*7450 *16,450	5000 11,050	*5100 *11,250	4200 9,300	
-1.5 m -5'	9.7 m 32'	*12600 *27,750	*12600 *27,750	*16500 *36,400	13900 30,700	*12000 *26,450	8950 19,800	*9250 *20,450	6450 14,250	*7350 *16,250	4900 10,850	*6000 *13,200	4450 9,850	
-3.0 m -10'	9.0 m 30'	*17250 *38,050	*17250 *38,050	*15500 *34,200	13900 30,650	*11450 *25,350	8900 19,650	*8800 *19,450	6400 14,150			*6800 *15,000	5050 11,150	
-4.6 m -15'	7.9 m 26'	*18500 *40,750	*18,500 *40,750	*13300 *29,400	*13300 *29,400	*9950 *22,000	9000 19,900	*7300 *16,100	6550 14,450			*6750 *14,950	6200 13,700	
-6.1 m -20'	6.3 m 21'	*12400 *27,400	*12400 *27,400	*9350 *20,600	*9350 *20,600	*6550 *14,450	*6550 *14,450					*6200 *13,700	*6200 *13,700	

*Load is limited by hydraulic capacity rather than tipping. Ratings are based on SAE standard No. J1097. Rated loads do not exceed 87% of hydraulic lift capacity or 75% of tipping load.

PC350HD-8 HYDRAULIC EXCAVATOR

LIFTING CAPACITIES



LIFTING CAPACITY

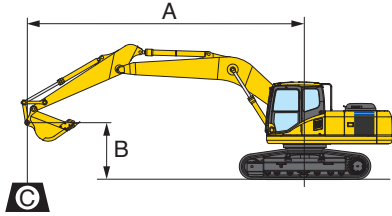

A: Reach from swing center
 B: Bucket hook height
 C: Lifting capacity
 Cf: Rating over front
 Cs: Rating over side
 :Rating at maximum reach

Conditions:
 • Arm: 2540 mm 8'4"
 • Boom length 6500 mm 21'3"
 • Bucket 1.40 m³ 1.83 yd³ (SAE heaped)
 –Bucket weight: 1021 kg 2,252 lb.
 • Lifting mode: On

PC350HD-8		Shoe: 800 mm 31.5"										Unit: kg/lb		
B	A	MAX	3.0 m 10'		4.6 m 15'		6.1 m 20'		7.6 m 25'		9.1 m 30'		MAX	
			Cf	Cs	Cf	Cs	Cf	Cs	Cf	Cs	Cf	Cs	Cf	Cs
7.6 m 25'	7.2 m 24'												*7600 *16,750	*7600 *16,750
6.1 m 20'	8.1 m 27'					*8850 *19,550	*8850 *19,550	*7950 *17,600	7700 17,700				*7450 *16,500	6850 15,150
4.6 m 15'	8.7 m 29'			*12800 *28,250	*12800 *28,250	*9900 *21,850	*9900 *21,850	*8400 *18,550	7500 16,550				*7650 *16,900	6000 13,250
3.0 m 10'	9.0 m 30'			*15400 *34,000	*15400 *34,000	*11100 *24,550	10150 22,350	*8950 *19,800	7250 15,950				*7800 *17,200	5550 12,250
1.5 m 5'	9.0 m 30'			*16850 *37,150	14700 32,400	*12050 *26,550	9650 21,350	*9450 *20,850	7000 15,450				*7900 *17,450	5400 11,950
0 m 0'	8.8 m 29'			*16750 *36,950	14400 31,750	*12300 *27,150	9400 20,750	*9550 *21,100	6800 15,050				*8000 *17,700	5550 12,300
-1.5 m -5'	8.2 m 27'	*15150 *33,400	*15150 *33,400	*15600 *34,450	14400 31,800	*11800 *26,100	9300 20,550	*9100 *20,100	6800 14,950				*8100 *17,900	6100 13,400
-3.0 m -10'	7.4 m 24'	*17050 *37,600	*17050 *37,600	*13500 *29,750	*13500 *29,750	*10350 *22,850	9400 20,800						*8000 *17,650	7250 16,000
-4.6 m -15'	6.0 m 20'	*11850 *26,150	*11850 *26,150	*9750 *21,550	*9750 *21,550								*7250 *16,000	*7250 *16,000
-6.1 m -20'														

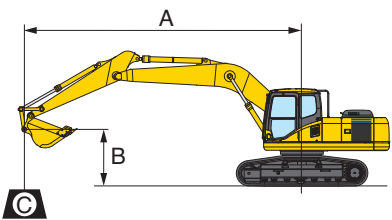

A: Reach from swing center
 B: Bucket hook height
 C: Lifting capacity
 Cf: Rating over front
 Cs: Rating over side
 :Rating at maximum reach

Conditions:
 • Arm: 3185 mm 10'5"
 • Boom length 6500 mm 21'3"
 • Bucket 1.40 m³ 1.83 yd³ (SAE heaped)
 –Bucket weight: 1021 kg 2,252 lb.
 • Lifting mode: On

PC350HD-8		Shoe: 800 mm 31.5"										Unit: kg/lb		
B	A	MAX	3.0 m 10'		4.6 m 15'		6.1 m 20'		7.6 m 25'		9.1 m 30'		MAX	
			Cf	Cs	Cf	Cs	Cf	Cs	Cf	Cs	Cf	Cs	Cf	Cs
7.6 m 25'	7.9 m 26'								*6350 *14,000	*6350 *14,000			*5300 *11,750	*5300 *11,750
6.1 m 20'	8.7 m 29'							*7350 *16,200	*7350 *16,200				*5250 *11,600	*5250 *11,600
4.6 m 15'	9.3 m 30'					*9150 *20,250	*9150 *20,250	*7900 *17,400	7600 16,800	*6250 *13,850	5550 12,300		*5400 *11,900	*5400 *11,900
3.0 m 10'	9.6 m 31'			*14350 *31,650	*14350 *31,650	*10500 *23,250	10300 22,800	*8550 *18,900	7300 16,150	*7400 *16,300	5450 12,050		*5750 *12,650	5050 11,150
1.5 m 5'	9.6 m 31'			*16400 *36,150	15050 33,200	*11650 *25,750	9800 21,650	*9200 *20,250	7050 15,550	*7650 *16,900	5300 11,700		*6300 *13,950	4950 10,900
0 m 0'	9.3 m 31'	*8850 *19,600	*8850 *19,600	*17000 *37,450	14550 32,100	*12250 *27,050	9450 20,900	*9500 *21,000	6850 15,100	*7650 *16,950	5200 11,500		*7250 *16,000	5050 11,150
-1.5 m -5'	8.8 m 29'	*14200 *31,350	*14200 *31,350	*16350 *36,100	14400 31,800	*12100 *26,750	9300 20,550	*9350 *20,650	6750 14,850				*7600 *16,800	5450 12,000
-3.0 m -10'	8.0 m 26'	*19950 *44,050	*19950 *44,050	*14700 *32,450	14550 32,050	*11100 *24,500	9350 20,600	*8400 *18,500	6750 14,950				*7700 *16,950	6300 13,900
-4.6 m -15'	6.8 m 22'	*15300 *33,700	*15300 *33,700	*11700 *25,850	*11700 *25,850	*8750 *19,350	*8750 *19,350						*7450 *16,450	*7450 *16,450
-6.1 m -20'														

*Load is limited by hydraulic capacity rather than tipping. Ratings are based on SAE standard No. J1097. Rated loads do not exceed 87% of hydraulic lift capacity or 75% of tipping load.



LIFTING CAPACITY

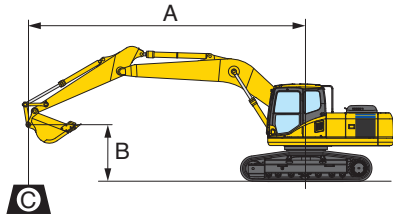

- A: Reach from swing center
- B: Bucket hook height
- C: Lifting capacity
- Cf: Rating over front
- Cs: Rating over side
- : Rating at maximum reach

- Conditions:
- Arm: 4020 mm **13'2"**
 - Boom length 6500 mm **21'3"**
 - Bucket 1.40 m³ **1.83 yd³** (SAE heaped)
 - Bucket weight: 1021 kg **2,252 lb.**
 - Lifting mode: On

PC350HD-8		Shoe: 800 mm 31.5"										Unit: kg/lb	
B	A	3.0 m 10'		4.6 m 15'		6.1 m 20'		7.6 m 25'		9.1 m 30'		MAX	
		Cf	Cs	Cf	Cs	Cf	Cs	Cf	Cs	Cf	Cs	Cf	Cs
7.6 m 25'	8.9 m 29'											*4000 *8,850	*4000 *8,850
6.1 m 20'	9.6 m 32'									*5650 *12,450	*5650 *12,450	*3950 *8,700	*3950 *8,700
4.6 m 15'	10.1 m 33'							*7050 *15,600	*7050 *15,600	*6450 *14,200	5600 12,400	*4000 *8,850	*4000 *8,850
3.0 m 10'	10.4 m 34'	*20150 *44,500	*20150 *44,500	*12550 *27,700	*12550 *27,700	*9450 *20,900	*9450 *20,900	*7850 *17,300	7350 16,200	*6800 *15,050	5400 12,000	*4200 *9,300	*4200 *9,300
1.5 m 5'	10.4 m 34'	*8400 *18,500	*8400 *18,500	*15100 *33,300	*15100 *33,300	*10850 *23,900	9850 21,750	*8600 *18,950	7000 15,450	*7200 *15,950	5250 11,550	*4550 *10,050	4200 9,300
0 m 0'	10.2 m 33'	*9250 *20,400	*9250 *20,400	*16450 *36,250	14450 31,850	*11750 *25,900	9350 20,700	*9100 *20,150	6700 14,850	*7450 *16,450	5100 11,250	*5100 *11,250	4250 9,450
-1.5 m -5'	9.8 m 32'	*12600 *27,750	*12600 *27,750	*16500 *36,400	14100 31,150	*12000 *26,450	9100 20,100	*9250 *20,450	6550 14,450	*7350 *16,250	5000 11,050	*6000 *13,200	4550 10,050
-3.0 m -10'	9.0 m 30'	*17250 *38,050	*17250 *38,050	*15500 *34,200	14100 31,100	*11450 *25,350	9050 19,950	*8800 *19,450	6500 14,350			*6800 *15,000	5100 11,300
-4.6 m -15'	7.9 m 26'	*18500 *40,750	*18500 *40,750	*13300 *29,400	*13300 *29,400	*9950 *22,000	9150 20,200	*7300 *16,100	6650 14,650			*6750 *14,950	6300 13,900
-6.1 m -20'	6.3 m 21'	*12400 *27,400	*12400 *27,400	*9350 *20,600	*9350 *20,600	*6550 *14,450	*6550 *14,450					*6200 *13,700	*6200 *13,700

*Load is limited by hydraulic capacity rather than tipping. Ratings are based on SAE standard No. J1097. Rated loads do not exceed 87% of hydraulic lift capacity or 75% of tipping load.

PC350HD-8 HYDRAULIC EXCAVATOR

LIFTING CAPACITIES



LIFTING CAPACITY

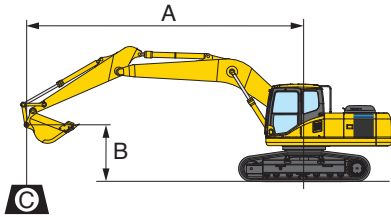

- A: Reach from swing center
- B: Bucket hook height
- C: Lifting capacity
- Cf: Rating over front
- Cs: Rating over side
- :Rating at maximum reach

Conditions:

- Arm: 2540 mm 8'4"
- Boom length 6500 mm 21'3"
- Bucket 1.40 m³ 1.83 yd³ (SAE heaped)
- Bucket weight: 1021 kg 2,252 lb.
- Lifting mode: On

PC350HD-8		Shoe 900 mm 35.5"										Unit: kg/lb	
A \ B	MAX	3.0 m 10'		4.6 m 15'		6.1 m 20'		7.6 m 25'		9.1 m 30'		MAX	
		Cf	Cs	Cf	Cs	Cf	Cs	Cf	Cs	Cf	Cs	Cf	Cs
7.6 m 25'	7.2 m 24'											*7600	*7600
												*16,750	*16,750
6.1 m 20'	8.1 m 27'					*8850	*8850	*7950	7800			*7450	6950
						*19,550	*19,550	*17,600	17,200			*16,500	15,350
4.6 m 15'	8.7 m 29'			*12800	*12800	*9900	*9900	*8400	7600			*7650	6050
				*28,250	*28,250	*21,850	*21,850	*18,550	16,750			*16,900	13,400
3.0 m 10'	9.0 m 30'			*15400	*15400	*11100	10250	*8950	7300			*7800	5600
				*34,000	*34,000	*24,550	22,600	*19,800	16,150			*17,200	12,400
1.5 m 5'	9.0 m 30'			*16850	14850	*12050	9750	*9450	7050			*7900	5500
				*37,150	32,750	*26,550	21,550	*20,850	15,600			*17,450	12,100
0 m 0'	8.8 m 29'			*16750	14550	*12300	9500	*9550	6900			*8000	5650
				*36,950	32,100	*27,150	20,950	*21,100	15,250			*17,700	12,450
-1.5 m -5'	8.2 m 27'	*15150	*15150	*15600	14550	*11800	9400	*9100	6850			*8100	6150
		*33,400	*33,400	*34,450	32,150	*26,100	20,800	*20,100	15,150			*17,900	13,600
-3.0 m -10'	7.4 m 24'	*17050	*17050	*13500	*13500	*10350	9550					*8000	7300
		*37,600	*37,600	*29,750	*29,750	*22,850	21,050					*17,650	16,150
-4.6 m -15'	6.0 m 20'	*11850	*11850	*9750	*9750							*7250	*7250
		*26,150	*26,150	*21,550								*16,000	*16,000
-6.1 m -20'													

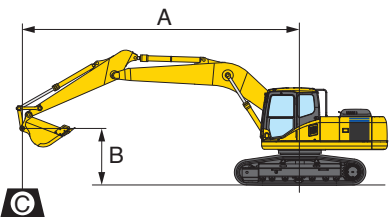

- A: Reach from swing center
- B: Bucket hook height
- C: Lifting capacity
- Cf: Rating over front
- Cs: Rating over side
- :Rating at maximum reach

Conditions:

- Arm: 3185 mm 10'5"
- Boom length 6500 mm 21'3"
- Bucket 1.40 m³ 1.83 yd³ (SAE heaped)
- Bucket weight: 1021 kg 2,252 lb.
- Lifting mode: On

PC350HD-8		Shoe 900 mm 35.5"										Unit: kg/lb	
A \ B	MAX	3.0 m 10'		4.6 m 15'		6.1 m 20'		7.6 m 25'		9.1 m 30'		MAX	
		Cf	Cs	Cf	Cs	Cf	Cs	Cf	Cs	Cf	Cs	Cf	Cs
7.6 m 25'	7.9 m 26'							*6350	*6350			*5300	*5300
								*14,000	*14,000			*11,750	*11,750
6.1 m 20'	8.7 m 29'							*7350	*7350			*5250	*5250
								*16,200	*16,200			*11,600	*11,600
4.6 m 15'	9.3 m 30'					*9150	*9150	*7900	7700	*6250	5650	*5400	*5400
						*20,250	*20,250	*17,400	16,950	*13,850	12,450	*11,900	*11,900
3.0 m 10'	9.6 m 31'			*14350	*14350	*10500	10450	*8550	7400	*7400	5500	*5750	5100
				*31,650	*31,650	*23,250	23,050	*18,900	16,350	*16,300	12,150	*12,650	11,300
1.5 m 5'	9.6 m 31'			*16400	15200	*11650	9900	*9200	7100	*7650	5350	*6300	5000
				*36,150	33,550	*25,750	21,900	*20,250	15,700	*16,900	11,850	*13,950	11,050
0 m 0'	9.3 m 31'	*8850	*8850	*17000	14700	*12250	9550	*9500	6900	*7650	5250	*7250	5100
		*19,600	*19,600	*37,450	32,450	*27,050	21,150	*21,000	15,250	*16,950	11,650	*16,000	11,250
-1.5 m -5'	8.8 m 29'	*14200	*14200	*16350	14600	*12100	9400	*9350	6800			*7600	5500
		*31,350	*31,350	*36,100	32,200	*26,750	20,800	*20,650	15,050			*16,800	12,150
-3.0 m -10'	8.0 m 26'	*19950	*19950	*14700	14700	*11100	9450	*8400	6850			*7700	6350
		*44,050	*44,050	*32,450	32,400	*24,500	20,850	*18,500	15,100			*16,950	14,100
-4.6 m -15'	6.8 m 22'	*15300	*15300	*11700	*11700	*8750	*8750					*7450	*7450
		*33,700	*33,700	*25,850	*25,850	*19,350	*19,350					*16,450	*16,450
-6.1 m -20'													

*Load is limited by hydraulic capacity rather than tipping. Ratings are based on SAE standard No. J1097. Rated loads do not exceed 87% of hydraulic lift capacity or 75% of tipping load.



LIFTING CAPACITY

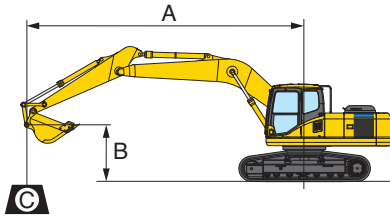

- A: Reach from swing center
- B: Bucket hook height
- C: Lifting capacity
- Cf: Rating over front
- Cs: Rating over side
- :Rating at maximum reach

Conditions:

- Arm: 4020 mm **13'2"**
- Boom length 6500 mm **21'3"**
- Bucket 1.40 m³ **1.83 yd³** (SAE heaped)
- Bucket weight: 1021 kg **2,252 lb.**
- Lifting mode: On

PC350HD-8		Shoe 900 mm 35.5"										Unit: kg/lb	
B	A	3.0 m 10'		4.6 m 15'		6.1 m 20'		7.6 m 25'		9.1 m 30'		MAX	
		Cf	Cs	Cf	Cs	Cf	Cs	Cf	Cs	Cf	Cs	Cf	Cs
7.6 m 25'	8.9 m 29'											*4000 *8850	*4000 *8,850
6.1 m 20'	9.6 m 32'									*5650 *12,450	*5650 *12,450	*3950 *8700	*3950 *8,700
4.6 m 15'	10.1 m 33'							*7050 *15,600	*7050 *15,600	*6450 *14,200	5650 12,550	*4000 *8,850	*4000 *8,850
3.0 m 10'	10.4 m 34'	*20150 *44,500	*20150 *44,500	*12550 *27,700	*12550 *27,700	*9450 *20,900	*9450 *20,900	*7850 *17,300	7450 16,400	*6800 *15,050	5500 12,150	*4200 *9,300	*4200 *9,300
1.5 m 5'	10.4 m 34'	*8400 *18,500	*8400 *18,500	*15,100 *33,300	*15,100 *33,300	*10850 *23,900	9950 21,950	*8600 *18,950	7100 15,650	*7200 *15,950	5300 11,700	*4550 *10,050	4250 9,450
0 m 0'	10.2 m 33'	*9250 *20,400	*9250 *20,400	*16450 *36,250	14600 32,200	*11750 *25,900	9500 20,900	*9100 *20,150	6800 15,050	*7450 *16,450	5150 11,350	*5100 *11,250	4350 9,550
-1.5 m -5'	9.7 m 32'	*12600 *27,750	*12600 *27,750	*16500 *36,400	14250 31,500	*12000 *26,450	9200 20,350	*9250 *20,450	6650 15,650	*7350 *16,250	5050 11,150	*6000 *13,200	4600 10,200
-3.0 m -10'	9.0 m 30'	*17250 *38,050	*17250 *38,050	*15500 *34,200	14250 31,450	*11450 *25,350	9150 20,200	*8800 *19,450	6600 14,550			*6800 *15,000	5200 11,450
-4.6 m -15'	7.9 m 26'	*18500 *40,750	*18500 *40,750	*13300 *29,400	*13300 *29,400	*9950 *22,000	9250 20,450	*7300 *16,100	6700 14,800			*6750 *14,950	6400 14,100
-6.1 m -20'	6.3 m 21'	*12400 *27,400	*12400 *27,400	*9350 *20,600	*9350 *20,600	*6550 *14,450	*6550 *14,450					*6200 *13,700	*6200 *13,700

*Load is limited by hydraulic capacity rather than tipping. Ratings are based on SAE standard No. J1097. Rated loads do not exceed 87% of hydraulic lift capacity or 75% of tipping load.



STANDARD EQUIPMENT

- Alternator, 60 Ampere, 24V
- AM/FM radio
- Auto-decel
- Automatic air conditioner with defroster
- Automatic engine warm-up system
- Batteries, large capacity, 2 x 12V, 150Ah
- Boom and arm holding valves
- Cab, damper mounted
- Counterweight 7371 kg **16,246 lb**
- Dry type air cleaner, double element
- Electric horn
- EMMS monitoring system
- Engine, Komatsu SAA6D114E-3
- Engine overheat prevention system
- Fan guard structure
- Fuel system 10 micron pre-filter
- High pressure in-line hydraulic filters
- Hydraulic track adjusters (each side)
- KOMTRAX®
- Large 7" TFT LCD monitor panel
- Operator Protective Top Guard (OPG), Level 1
- Pattern change valve
- Power maximizing system
- PPC hydraulic control system
- Radiator and oil cooler dustproof net
- Rearview camera (1)
- Revolving frame deck guard
- Revolving frame undercovers
- Rearview mirrors (LH & RH (2 pieces))
- Seat belt, 76 mm **3"** retractable
- Seat, suspension
- Service valve (1 additional)
- Shoes, triple grouser: 800 mm **31.5"**
- Slip resistant foot plates
- Starting motor 11 kW/24V x 1
- Suction fan
- Track guiding guard, center section
- Travel alarm
- Two boom mode settings
- Undercover for track frame center
- Working lights, 2 (boom and RH front)
- Working mode selection system



OPTIONAL EQUIPMENT

- (1) Additional rearview camera, RH side
- Air ride suspension seat
- Arms
 - 2540 mm **8'4"** arm assembly
 - 3185 mm **10'5"** arm assembly
 - 3185 mm **10'5"** with one actuator piping
 - 4020 mm **13'2"** arm assembly
- Boom
 - 6500 mm **21'3"** HD boom assembly
 - 6500 mm **21'3"** HD with one actuator piping
- Convertor, 12V
- Full front guard Level 1
- Full front guard Level 2
- One actuator hydraulic control unit
- OPG top guard, Level 2, bolt-on
- Rain visor
- Revolving frame undercovers, heavy duty
- Shoes, triple grouser: 700 mm **28"**
- Shoes, triple grouser: 900 mm **35.5"**
- Straight travel pedal
- Sun visor
- Track frame undercover, heavy duty
- Track roller guards (full length)
- Two actuator hydraulic control units
- Working light, front, one additional



ATTACHMENT OPTIONS

- JRB attachments
 - Couplers
 - Smart-Loc
 - Versa-Loc
 - Vandal protection guards with storage box
- Komatsu buckets
- Lincoln autolube systems
- PSM thumbs
- Rockland thumbs

For a complete list of available attachments, please contact your local Komatsu distributor.

KOMATSU®