

**P 240 AXE** *Smart*

**PALFINGER**

LIFETIME EXCELLENCE

**SOLUTION IDÉALE EN TERMES DE PERFORMANCES ET DE DIMENSIONS, FIABILITÉ DE LA TECHNOLOGIE HYDRAULIQUE ET EFFICACITÉ DU PRODUIT.**



# P 240 AXE *Smart*

## COURBES DE TRAVAIL

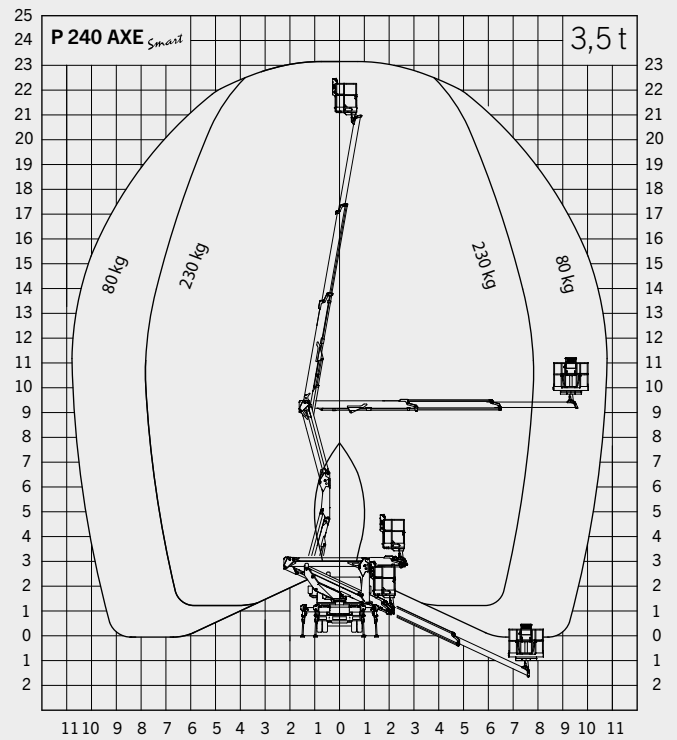
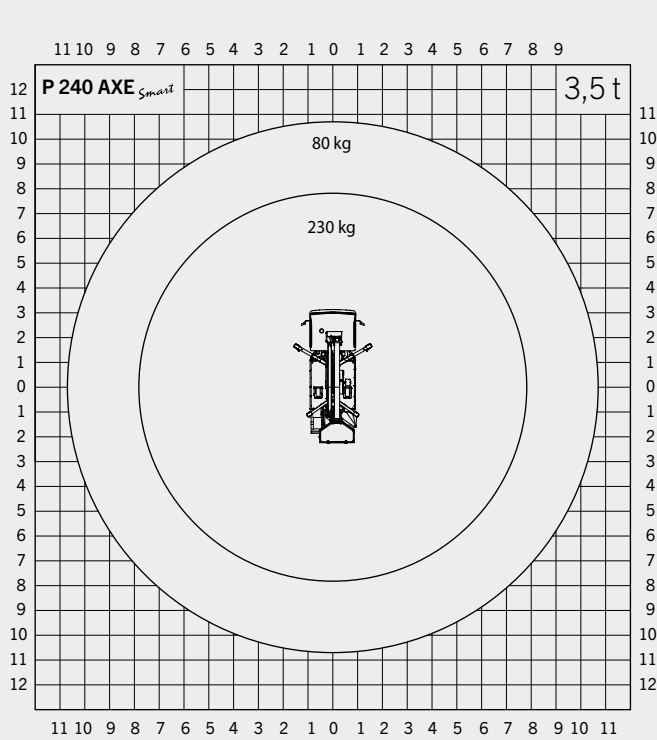

## DIMENSIONS

