

M900/M900i TRAILED SPRAYERS



4400, 5200, 6200 litres



SIMPLY IDEAL



High performance, maximum uptime and lowest possible operating costs – that’s what you should be looking for in your new machinery and that’s exactly what you get with the M900/M900i Series sprayer. Performance levels are high, thanks to spraying accuracy and overall ease of operation. And because it shares components with the proven R900i, uptime and reliability are guaranteed. Built-in efficiency also keeps running costs to a minimum and you can specify your M900/M900i to ensure that it is ideal for your operations.

Whether you’re growing cereals or high-end speciality crops, you’ll be able to configure your ideal M900/M900i Series sprayer the most cost-effective way; with the perfect specification for your operations. No more and no less than you need and no unnecessary outlay for superfluous technology. That’s the philosophy behind our new M900/M900i trailed sprayer.



Contents

- Introduction 2
- Better Together 4
- Meet the Machine 6
- Chassis & Tank 8
- Spraying Cycle.....10
- Documentation.....12
- Filling14
- Transport.....16
- Booms18
- Spraying 20
- Rinsing & Dilution 22
- Receiver and Displays24
- Specifications 26

It's an impressive performer based on the successful R900i Series, sharing the same large tank cradled in the same robust chassis for unsurpassed operational stability. All manual controls and adjustments are optimised for ease of operation and it is particularly easy to service and maintain. And, of course, there's the renowned John Deere quality and reliability.



A PARTNERSHIP
OF QUALITY:
SIMPLY A WAY
OF LIFE

Every successful partnership is based on trust and understanding. At John Deere, trust is evident in the legendary quality and reliability of our machinery, the innovative effectiveness of our user-friendly systems and the meticulous support provided by our dealers. We also understand exactly what you need to achieve and maintain the success of your operations: equipment that is designed and engineered to outperform anything in the field, a support network dedicated to maximise operational uptime and proven cost efficiency.

Sharing this unique trust and understanding is what makes us better together.



Maximising uptime

In the field or on the road, uptime equals productivity. To keep your operations up and running, we've made it our priority to develop effective new solutions to eliminate machine downtime. The John Deere parts logistics infrastructure consists of a fully integrated network of parts distribution centres stretching from the UK to Russia. Obtaining and fitting our genuine parts has never been quicker or simpler. Ask your John Deere dealer – he's already part of our "on call" team.

MAXIMISING

UPTIME



PEERLESS

PERFORMANCE

MINIMISING

OPERATION COSTS



Peerless performance

We define machine performance as much more than just power. It also means precise regulation of crop inputs, the highest possible productivity and a proficiency that has no equal. Our sprayers are designed and manufactured in a purpose-built European facility, so the quality of your work is assured by the quality of our machinery.

Minimising operation costs

There's no escaping the truth that skimping on quality can turn out to be expensive in the long run. And the long run is exactly what John Deere machines are built for. The quality for which we are renowned pays real dividends in terms of impressive reliability and durability, lower running costs and a reduced need for maintenance. All of which contribute to higher residual – therefore better resale – values.



BoomGuard suspension system ensures a smooth boom ride on the road and in the field.

Unique pendulum construction makes booms self levelling

- Anti-yaw system minimises boom movement
- End stroke damping for smooth boom folding
- Stable, symmetrical boom folding



The ultimate sophistication: simplicity

How simple? You decide.

Nobody knows better than you just how much sophistication you need. Which is why we've created our M900/M900i Series trailed sprayers. By configuring the specification that best suits your operations, you can be sure that you're not investing in any unnecessary sophistication. But you'll always have the advantage of sharing the same proven chassis, tank and other major components of the R900i Series sprayers.

- Advanced i-Solutions bring precision and save input costs
- 12 volt power connection or tractor ISOBUS socket
- GPS Section Control ready
- BoomTrac automation (spray boom levelling and height control)
- PTO or hydraulic pump drive
- TwinSelect nozzle system (optional on M900i)
- Manual or automated filling and dilution
- Unrivalled boom stability and longevity, up to 40 metres
- Working lights for higher night time productivity, LED lights for ISOBUS controlled versions
- 2 x 280 l/min pump capacity, 250 l/min at the boom
- 620 l rinse water tank
- John Deere quality and service



1

Hydraulic pump drive (option)

Hydraulic driven sprayer pumps provide more tractor rpm in-dependency. The over-speed protection prevents spray pump damage.

2

Chassis:

The entire chassis is designed specially for the job. The heart of the main frame is the cross structure in the centre section which absorbs torque and movement better.

3

PowrFill chemical inductor:

This specially designed chemical inductor fills large volumes quickly, accurately and safely. A powerful injector draws in crop protection chemicals quickly, limiting the risk of foaming.

4

Filling and rinsing:

Choice of manual or semi-automated systems.

BoomTrac improves spray accuracy and distribution – and reduces drift – by automatically controlling boom tilt and height as you work. It's particularly useful on slopes and uneven fields, as well as during headland turns.

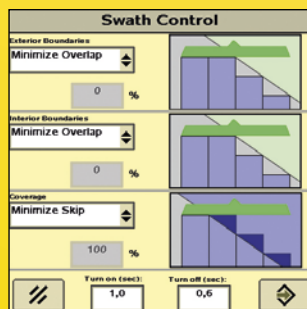

Sectional Control cuts input costs by reducing skips or overlaps dramatically. This GPS-based system turns boom sections on and off automatically whenever you leave or enter a predefined area.



5 ProRoad:
Double-link axle suspension with maintenance-free polyurethane dampers. For a smooth, stable ride on the road and the field – no matter how full or empty your sprayer is.

6 Double and triple folding booms:
Choose from a wide range of booms with proven John Deere stability, with available boom widths of up to 40 m. The spray pump capacity is 2 x 280 l/min, minimising potential flow disruption. 250 l/min is available at the boom.

7 AutoDilute (optional):
This automatic multi-cycle rinse programme and residue disposal management system features automatic stepwise residue dilution or continuous dilution.

8 TwinSelect in-cab nozzle control helps to save valuable time whenever there is a need to change nozzles

SUPERIOR STABILITY: A SIMPLE SOLUTION



ALL THE CAPACITY YOU NEED

With three tank sizes available (4400 l, 5200 l and 6200 l nominal volumes), it's simplicity itself to identify the right M900/M900i for your operation. All are built to the same exacting standards.

Manufactured in rugged, durable polyethylene, they're designed for years of trouble-free service. The

smooth, rounded shape enables perfect agitation and is easy to keep clean, inside and out. The deep sump and steeply sloping bottom minimise dead volume and makes emptying easy – even on hillsides. There are no baffles or dead corners to disrupt flow, agitation or solution mixing, while digital readout – standard with automatic filling – and dry liquid level indication are standard.



The lower the centre of gravity, the better the balance. Making the M900/M900i better for stability, manoeuvrability, accuracy and transport, whether the tank is full or empty, on the road and in the field. Even on slopes!

The tank sits low in the chassis, cradled within the rugged main frame, giving the M900/M900i a very low centre of gravity. The resulting stability and level weight distribution help keep the machine steady while working, regardless of boom position. The durable chassis design limits frame material fatigue.

Optional wheel steering provides hillside adjustment and serves as a track-following system on headlands, reducing crop damage and steering your machine manually or automatically.

- Narrow drawbar design and single axle for sharper turning
- Height-adjustable tow-eye connection
- Integrated hydraulic parking jack
- ProRoad double-link axle suspension for better spray accuracy



For smooth steering, we fit proportional hydraulic control as standard. Wheel steering can be controlled either manually or automatically – or even controlled via GPS / GLONASS in combination with Sectional Control.

MULTI-MODE STEERING

Choose 'manual' when entering fields or reversing into corners or 'auto' for consistent track following. 'HMS' activates the steering when you're not spraying at the headland. .



PRECISION SPRAYING: AS SIMPLE AS 1, 2, 3 ...

When it comes to effective crop protection, timing and technology are almost as important as choosing the right crop protection chemicals.

Based upon the proven R900i Series, the M900/M900i is capable of delivering impressive productivity every step of the way. From planning through filling and transport to spraying, rinsing and dilution, it makes spraying easier, more accurate and more profitable. With the optional GreenStar 3 display in the M900i, documentation is also included. The M900/M900i also complies with all legal and environmental restrictions right across Europe.

KEEPING YOUR PROFITS ON TRACK

Choose from a range of John Deere connectivity solutions that enable different degrees of accuracy and productivity enhancement. Your dealer will assist you in specifying the most effective and efficient solutions for your specific requirements.

THESE ARE ONLY A FEW OF THE EXCITING POSSIBILITIES:

- **MyJohnDeere.com:** The agricultural web portal enables you to plan, run and manage your operations – all from a central location.
- **Documentation:** you'll have everything you need to meet legal requirements, agricultural subsidies and reliable crop traceability at the click of a mouse.
- **Wireless Data Transfer:** Once a field is finished, data such as yield maps or as applied maps is automatically transferred to the Ag web portal MyJohnDeere.com
- **Remote Display Access:** you or your John Deere dealer can provide immediate advice on machine set-up and operation that will optimize the working efficiency of your operators and machines.

DOCUMENTATION > 1

FILLING > 2

TRANSPORT > 3

SPRAYING > 4

DILUTION AND RINSING > 5



5

1

2

3

4

1

DOCUMENTATION: PREPARATION IS EVERYTHING

Equipped with the optional GreenStar 3 2630 touch-screen display, your M900i boosts your productivity throughout the entire crop protection cycle – from documentation and filling to transport, spraying and rinsing.

Good documentation provides the solid foundation for your entire operation. With the right data, you can work more productively every season by creating prescription maps that take yields higher still, season after season.

From the simplicity of manual control to the convenience of John Deere i-Solutions, you can specify your M900i according to your operational preferences.

An M900i equipped with the full suite of i-Solutions can help you streamline every aspect of your job planning and data recording. All the information you need on crop protection processes and traceability are collected automatically while you work. You can then either exchange them with your office PC, or print them out on your printer in the cab (optional).

Depending on your workflow requirements, you can also use desktop software from your John Deere partner in Europe. Thanks to our special cooperation model, you can be sure that your software has been perfectly tailored for your market.

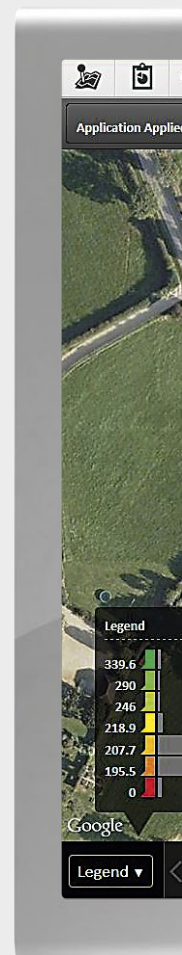

Once you experience how much time and effort you save on paperwork and planning, you'll wonder how you ever managed without i-Solution productivity.

It's your choice.

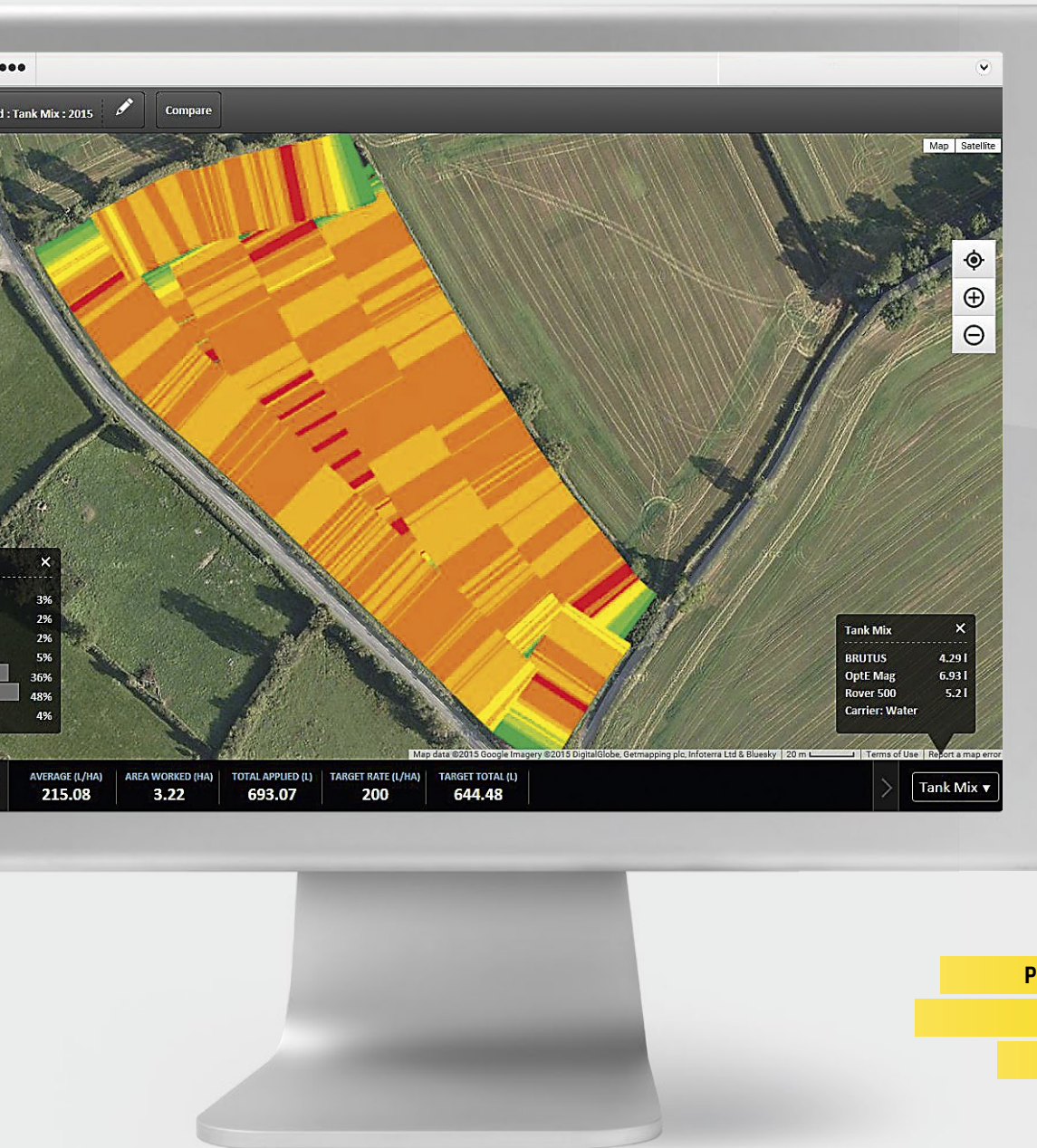

PRESCRIPTIONS AND MAPPING
REAL TIME DATA RECORDING
TRANSFER AND ANALYSIS



FIELD DOC

This real-time documentation software records all operations automatically – then lets you transfer them to your MyJohnDeere.com account for analysis later on.

Please note: these GPS-based tools require a GreenStar 3 2630 display and a StarFire receiver. Contact your dealer for details



SPRAY-TO-MAP (PRESCRIPTION MAPPING)

Need to spray variable rates? No problem: just create prescribed application maps on your office PC, import them to the GreenStar 3 2630 display in your cab ... and you're ready to go. Or connect your cropsensor to the GreenStar 3 2630 display*

*ask your John Deere dealer for the possibilities.

TANK FILL CALCULATOR

Next time you plan a job, forget about pencils and paper. Tank Fill Calculator tells you right away how much of each chemical you'll need for the whole job, as well as for each tank fill, or the partial fill you need to finish off.

All you do is enter key data such as field size, spray rate and applied crop protection chemicals, then set your mix. Tank Fill Calculator does the rest in seconds – automatically, and without errors. Since the calculations are based on the real-time data recorded as you spray, that means no more wasted time or chemicals!



2

FILLING: CONTROL MADE EASY

Operation could not be easier or more convenient. The ergonomic operator station is equipped with large valve handles that minimise the possibility of mistakes and save valuable time during machine set-up. Optional automation makes filling, spraying and rinsing even faster, easier and more precise. Back-flow is prevented by the standard non-return check valve. Such smart solutions protect the environment by preventing point-source pollution and chemical spillage. Located next to the valves is the PowrFill chemical inductor hopper, spray gun and clothing lockers. Filters and hose connections are perfectly located for ease of operation.

- Durable manual valves
- Faster filling via 3" fill hose connection
- Self-priming pumps
- Transfer valve, 2" quick fill for rinse water tank, Ecomatic connection (optional)
- Automatic filling and AutoDilute multi-cycle residue management system (optional)





POWRFILL CHEMICAL INDUCTOR

Fast, clean filling could not be simpler. The PowrFill inductor handles large input volumes in the shortest of time. Its powerful injector quickly draws the crop protection chemicals into the tank, minimising the risk of foaming. Complete with clothing locker and integrated hand wash tank with tap.

- Off-centre rotating rinse nozzle accommodates non-standard packages
- Can be operated safely with either hand
- Inductor lid with rinsing head for easy inside cleaning



KEEP IT CLEAN

After filling, wash your hands in the separate wash tank that holds up to 20 l of clean water.



KEEP IT STORED

The standard storage locker is ideal for transporting items you may need, including a change of clothing.



BoomGuard: spray booms are particularly vulnerable to stress and wear during fast on-road transport.

BoomGuard keeps vibration to a minimum, however rough the going gets. Pressurised accumulators in the boom lift provide extra support, while a special transport roller cradles the boom gently but firmly. For longer boom life and less risk of damage.

1

3

Transport: built for speed and stability

With its low centre of gravity and even weight distribution, the on-road performance of the M900/M900i Series sprayer is exemplary.

Even with a full tank it can be trailed safely and easily at speeds of up to 40 km/h*.



*where legally permitted

PROROAD AXLE SUSPENSION

Jolts and vibrations stress both operator and machine equally. This double link axle suspension features tough, maintenance-free polyurethane dampers that absorb shocks both on the road and in the field. Combined with torque-resistant chassis design that minimises the possibility of material-fatigue, this contributes to the long working life of the M900/M900i Series.

- Enhanced comfort
- Smoother ride
- Better spray accuracy
- Underside designed for smooth passage over crops





Low-slung design: The low centre of gravity and even weight distribution ensure safe, easy handling at speeds up to 40 km/h*.



ProRoad: this double-link axle suspension system has special polyurethane dampers to absorb shocks on the road and in the field. For more comfort, greater spray accuracy and a longer sprayer life.

2

3

FAST & EASY TRANSPORT

RUGGED & DURABLE

UP TO 40 KM/H*



*where legally permitted

4

5



K-80 ball type hitch is required for a positive connection to the tractor.
Slim drawbar design for sharp turns and smooth tracking on the headlands.



Chemical storage box. For additional productivity on the road, chemicals are stored safely in a 200 l lockable storage box.

BOOMS: HIGH ACCURACY, LOW WASTAGE

Precision spraying is dependent on boom stability, and John Deere booms are renowned for their stability and durability. We offer a wide range of double and triple folding steel booms, all with the quality features that ensure reliable, high-precision performance – year after year.

ACCURACY STARTS WITH BOOM STABILITY

An unstable boom leads directly to chemical wastage and poorer yields. All John Deere booms have the stability and features that precision spraying demands. And accuracy reduces wastage, thus promoting productivity.

- Central pendulum for boom levelling
- BoomGuard anti-yaw suspension minimises wear and tear
- End-stroke damping in boom fold cylinders

- Sturdy ball-and-socket hinges with grease points for extended boom life
- Reliable pressure circulation system provides instant chemical flow when starting
- Vertical and horizontal boom breakaway
- Stainless steel spray lines with quick connectors

Double folding boom operation is via the tractor SCV or by selecting the optional electro-hydraulic system. Electro-hydraulic control is required for triple folded booms and variable geometry operation.





Spray boom (M952/M952i/M962/M962i)

Double fold booms 24 - 30 meter	No. of sections		
24 / 12 m	4	6-6-6-6	
24 / 12 m	6	4-4-4-4-4-4	
24 / 12 m	8	3-3-3-3-3-3-3-3	
27 / 15 m	9	3-3-3-3-3-3-3-3-3	
28 / 14 m	7	4-4-4-4-4-4-4	
28 / 14 m	8	3-4-4-3-3-4-4-3	
30 / 15 m	9	3-4,5-3-3-3-3-4,5-3	

Triple fold booms 27 - 40 meter	No. of sections	Section widths, m	
27 / 18 m	7	4.5-4.5-3-3-3-4.5-4.5	
27 / 21 m	9	3-3-3-3-3-3-3-3-3	
28 / 20 m	7	4-4-4-4-4-4-4	
30 / 21 m	9	4,5-3-3-3-3-3-3-4,5	
32/21 m	8	4-4-4-4-4-4-4-4	
33 / 21 m	9	3-3-4,5-4,5-3-4,5-4,5-3-3	
33 / 21 m	11	3-3-3-3-3-3-3-3-3-3-3	
36 / 24 m	9	4-4-4-4-4-4-4-4-4	
36 / 24 m	12	3-3-3-3-3-3-3-3-3-3-3-3	
39 / 27 m	9	4,5-4,5-4,5-4,5-3-4,5-4,5-4,5-4,5	
39 / 27 m	13	3-3-3-3-3-3-3-3-3-3-3-3-3	
40 / 27 m	13	3,5-3-3-3-3-3-3-3-3-3-3-3,5	

MULTI FUNCTION CONTROL LEVER

All critical functions, frequently used during spraying, are operated with the multi function control lever: Master on/off, boom section control, boom height, boom tilt, variable geometry, boom folding and activation of BoomTrac.



*All booms are available with ringline circulation or pressure circulation or in cab nozzle control

SPRAYING: PRECISION DELIVERY

4

The M900/M900i Series makes every drop of chemical count, by taking the guesswork out of spraying. John Deere technologies help your operators cover more hectares with a single tank fill.

PUMP UP THE POWER

The 2 x 280 l/min self-priming pumps work together when filling and deliver fluid where it's needed by minimising the potential flow disruption. Depending on the size and quantity of nozzles, a maximum 250 l/min flow can be maintained at the boom for improved consistency and capacity.

RINGLINE CIRCULATION

This simple, rugged system lets you charge the system with chemicals right up to the section valves in the sprayboom before you start to spray.

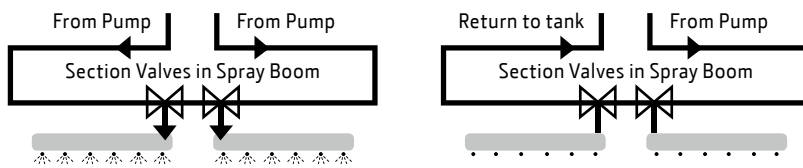

PRESSURE CIRCULATION

This system circulates chemicals right up to the nozzles before you start to spray. In spray mode the liquid enters from both sides into the sprayline ensuring a constant pressure and application rate.

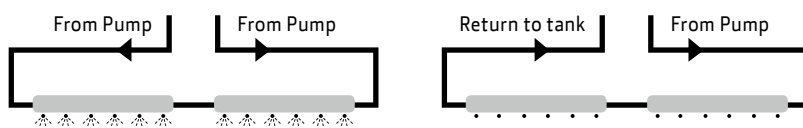

TWINSELECT

Changing nozzles when the weather dictates or moving from spraying chemicals to fertilisers is as simple as pushing a button with TwinSelect. This innovative option saves time, adds greater flexibility and helps you cover more hectares every spraying day.

ACCURACY

The durable parallelogram construction provides equal height adjustment speed and rear-side clearance. Boom Height Assist or optional BoomTrac height control help initiate spraying at the correct height for excellent spray distribution. BoomGuard absorbs vertical and horizontal movements and limits pitching, yaw and rolling.



John Deere section control takes full control of the boom sections, automatically switching them on and off when you leave or enter predefined areas and also the headland.

Even with less experienced operators and even in wedge-shaped fields, it reduces skips or overlaps – and hence your input costs for chemicals are reduced.



- OUTSTANDING ACCURACY
- PRECISE CONTROL
- HIGHLY PRODUCTIVE



BoomTrac (optional on M900i)

Automatically controls boom tilt and your boom's height above the crop or at the headland. That means one less thing to worry about – particularly on slopes or uneven fields.



Map based Variable Rate Application

Different areas need different amounts of crop care. This technology lets you set your application rates in advance, using prescription maps you prepare on your office PC. In the field, your sprayer then makes all the adjustments in real time, leaving operators free to focus on quality and productivity. The software you need to run Variable Rate Applications in the field comes preloaded on your GreenStar 3 2630 display.



John Deere Spray Nozzles

The nozzle is the business end of the sprayer, so it pays to use the best. The wide range of John Deere nozzles includes Variable Pressure, liquid fertiliser and leading edge air-inclusion low drift nozzles. For optimum coverage in challenging conditions, nozzles featuring an angled spray pattern help to penetrate around plant stems and foliage. Selecting the right nozzle for your conditions can seem daunting. Your John Deere dealer has the knowledge, experience and tools to help you make the right choice.

RINSING & DILUTION: CLEAN SOLUTIONS

You can rinse and dilute quickly and effectively, all from the comfort of your cab. Simply select the programme you want on the GreenStar display, then let the machine do all the work.

Presets are designed to meet all EU legislative requirements and make sure even less experienced operators obtain good results every time.

Everything about the M900/M900i is designed to streamline rinsing and dilution procedures. The rounded tank eliminates flow-disruptive corners and baffles and you can clean right through the spray lines without losing a drop from the nozzles, thanks to the pressure circulation system.





IN CAB RINSING
SIMPLE AND EFFICIENT
NO MISTAKES

AutoDilute

This optional system calculates how much clean water and how many cycles you need to achieve a given dilution factor. It takes all dead volume and remaining contents into account.

AutoDilute pre-sets are designed to meet all EU legislative requirements and make sure even less experienced operators obtain good results every time.

- Comfortable, in-cab control over the entire dilution process
- 2 modes: AutoDilute or ContinuousDilute
- Faster rinsing for higher productivity
- Fewer operator errors

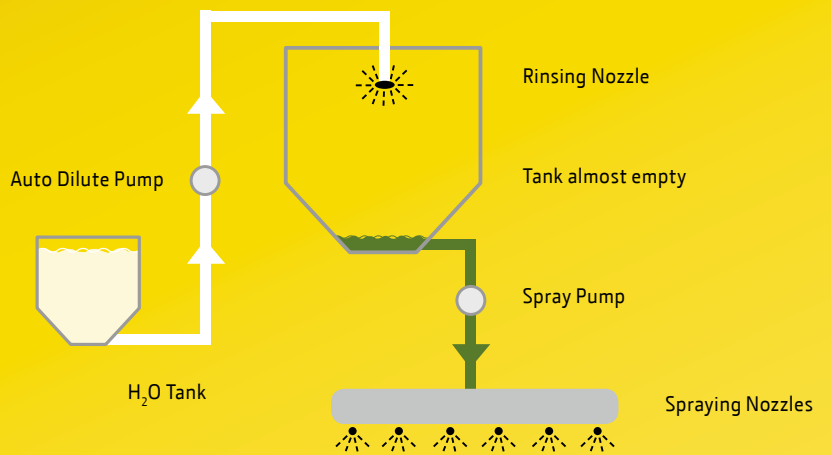

CUSTOMISING YOUR SPRAYER: NOTHING COULD BE SIMPLER

IMPLEMENT DISPLAY 1100

This 4.3" full colour display provides simple, manual sprayer control via the standard 12 Volt connection.

- Scroll wheel (provides easy navigation)
- IP 65 water protection

	ISOBUS	Docu- mentation	Section Control	Semi- Automated Filling	My John Deere
Implement Display 1100					
GreenStar 2 1800 Display	X		X*	X	
GreenStar 3 2630 Display	X	X	X	X	X
Command Center 3 display	X		X*	X	
Command Center 4 4100 display	X				
Command Center 4 4600 display	X		X	X	

*only with John Deere equipment

THE GREENSTAR 2 1800 DISPLAY

Looking for outstanding flexibility, comprehensive guidance, realistic field views and ISOBUS implement control? Take a closer look at our GreenStar 2 1800 Display!

- 7-inch full colour push-button display
- Easy to navigate scroll wheel
- ISOBUS compatible (Virtual Terminal)
- John Deere Documentation Basics
- Compatible with GreenStar Lightbar, ATU 200, AutoTrac Controller and integrated AutoTrac
- GreenStar SprayerPro enabled
- Compatible with both M900 (non-ISOBUS) and M900i (ISOBUS)
- Compatible with StarFire 300 and StarFire 3000 receivers



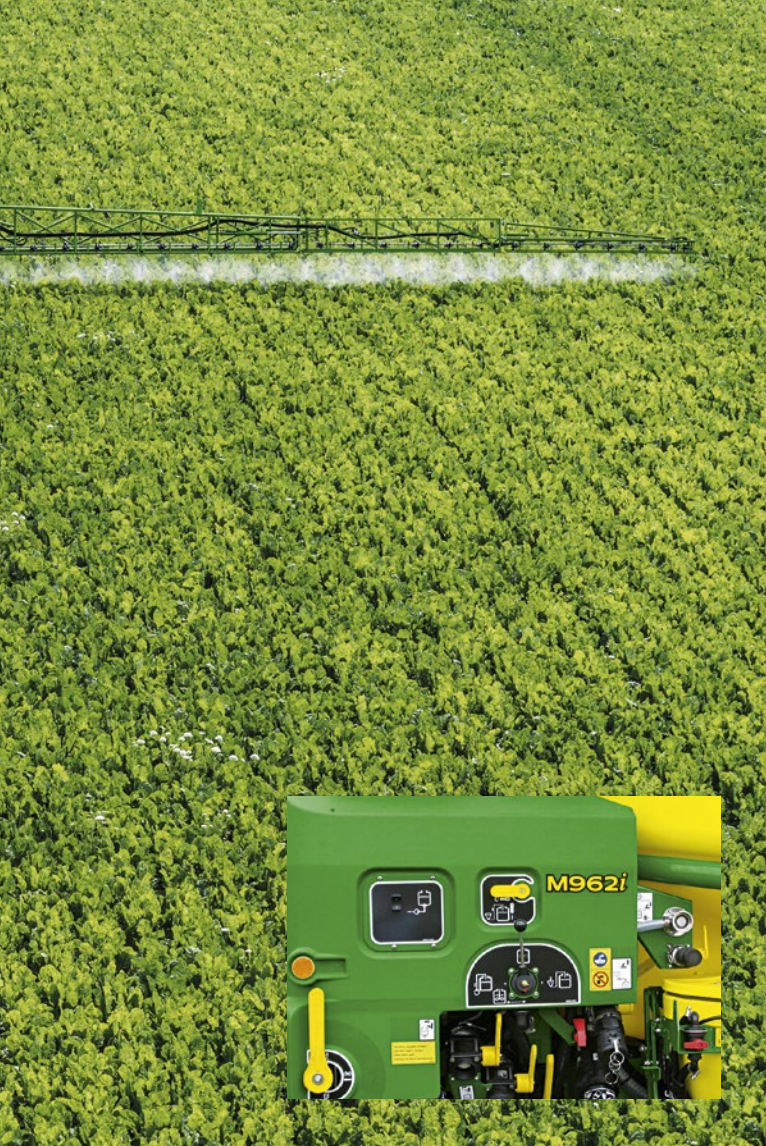

EDGE NOZZLE HOLDER

Should be positioned at the end of the spray boom and fitted with edge spray tips to prevent spraying directly into the watercourse. Two types of edge nozzle holders are available: manual or electrical.

ONBOARD HIGH PRESSURE WASHER

This optional 100 bar high pressure washer cleans both the sprayer and its booms in the field. Onboard hydraulically driven, it comes with a 16 m hose, hose reel and spray gun.

SELF-CLEANING PRESSURE FILTER

The optional self-cleaning filter kit allows operators to flush debris that may have collected in the base of the pressure filter without removing the filter bowl.

HYDRAULIC PUMP DRIVE OPTION

Eliminate the PTO shaft with our Hydraulic Pump Drive: Easier tractor connection, reduced maintenance and pump protection included.

CLOSED CHEMICAL TRANSFER ECOMATIC SYSTEM OPTION.

The sprayer can be equipped with a closed chemical transfer filling system for use of larger, refillable containers for easier handling of agrochemicals.

BOOM SUSPENSION KIT FOR HILLY FIELDS*

To enhance the boom ride at higher operating speeds or in hilly terrain, simply mount the compression springs between the centre pendulum and boom back frame.

For easier handling of chemicals use the closed chemical transfer ECOMATIC System.

THE GREENSTAR 3 2630 DISPLAY

As your business grows, so do your challenges. The GreenStar 3 2630 already has the future built in. This full colour touch-screen display gives you full monitoring and control over all the i-Solutions you use in your John Deere tractor, Self-Propelled Forage Harvester, combine or sprayer.

- Guidance and advanced Guidance
- Documentation and Variable-Rate Application
- Advanced ISOBUS capabilities (e.g. John Deere Section Control)
- Automatic implement detection
- Brilliant 26 cm touchscreen, video enabled
- Performance monitoring
- USB port for data transfer
- Standby mode for road transport or night-time use



STARFIRE 3000 RECEIVER

This advanced positioning receiver works seamlessly with GPS and GLONASS satellite constellations, all accuracy levels and all John Deere guidance systems. From Parallel Tracking manual guidance to the integrated automatic steering of AutoTrac, the StarFire 3000 will grow with your business for years to come.

- Improved resistance to shading
- Reliable on every terrain
- Faster satellite acquisition
- 3D Terrain Compensation Module



Technical Specification

M900 SERIES SPRAYER SPECIFICATIONS	M944	M952	M962	M944i	M952i	M962i
Nominal tank volume, l	4400	5200	6200	4400	5200	6200
Real tank volume, l	4620	5460	6510	4620	5460	6510
Rinse tank, l	Nominal 620	Nominal 620	Nominal 620	Nominal 620	Nominal 620	Nominal 620
Hand wash tank, l	18	18	18	18	18	18
12 volt Cobo Connector	Base	Base	Base	Base	Base	Base
ISOBUS	n/a	n/a	n/a	Base	Base	Base
Sprayer Control with multi functional lever (Joystick)	Base	Base	Base	Base	Base	Base
Implement display 1100	Base	Base	Base	n/a	n/a	n/a
GS 1800 display	Option	Option	Option	Base	Base	Base
GS 2630 display	n/a	n/a	n/a	Option	Option	Option
Self priming piston diaphragm sprayer pumps	Base	Base	Base	Base	Base	Base
Pump capacity, 2 x 280 l/min (max 250 l/min to boom)	Base	Base	Base	Base	Base	Base
PTO pump drive	Base	Base	Base	Base	Base	Base
Hydraulic pump drive	Option	Option	Option	Option	Option	Option
Spray pressure min- max, bar	1 - 8	1 - 8	1 - 8	1 - 8	1 - 8	1 - 8
PowrFill Inductor hopper cappacity, conical shaped 50L	Option	Option	Option	Base	Base	Base
Ground Clearance under axle,* m	0.7 - 0.9	0.7 - 0.9	0.7 - 0.9	0.7 - 0.9	0.7 - 0.9	0.7 - 0.9
ProRoad Polyurethane double linked Axle Suspension	Base	Base	Base	Base	Base	Base
Track width availibility, cm	180 - 225	180 - 225	180 - 225	180 - 225	180 - 225	180 - 225
Clothing locker	Option	Option	Option	Base	Base	Base
Closed chemical storagebox with lock	Option	Option	Option	Option	Option	Option
Optional wheel steering with proportional hydraulics with headland management system , minimum turning radius 8 metres*	Option	Option	Option	Option	Option	Option
BoomTrac automatic boom tilt and height control with headland management	n/a	n/a	n/a	Option	Option	Option
Lower linkage connection (height adjustable)	Base	Base	Base	Base	Base	Base

*Depending on track width and selected tyres

SPECIFICATIONS SOLUTION SYSTEM	M944	M952	M962	M944i	M952i	M962i
Manual operated valves	Base	Base	Base	Base	Base	Base
Automatic tank filling system (Free programmable) with electric valves includes overflow protection, Multi cycle residue management system (Auto Dilute)	Option	Option	Option	Option	Option	Option
Integrated non return checkvalve in suction side limits backflow	Base	Base	Base	Base	Base	Base
Digital tank level sensor with detailed readout in display	Option	Option	Option	Option	Option	Option
Automatic agitation on /off control Based on tank level, (free programmable)	Option	Option	Option	Option	Option	Option
Sprayrate control by presurre- and flow sensor	Option	Option	Option	Base	Base	Base
Cross flow check (detects nozzle wear, sprayline blockage or wrong programmed nozzle sizes)	Option	Option	Option	Base	Base	Base
Anticipation factor in software ensures concentrated start when manually switching sections at the headland	Option	Option	Option	Base	Base	Base
Start Delay Pressure regulator prevents under dosage at spray start in corner	Option	Option	Option	Base	Base	Base
Low Flow Detection automatic sprayrate sensor selection if flow is out of measurement range of the flow sensor.Ppressure sensor takes command.	Option	Option	Option	Base	Base	Base
Default setting pressure regulator, prevents overdose at spray start after refill the tank	Option	Option	Option	Base	Base	Base

WEIGHTS*	M944/M944i	M952/M952i	M962/M962i
Total weight empty, kg	5350	5370	5390
Total weight full, kg	10346	11170	12200
Tow eye load, kg	2280	2600	3000
Axle load, kg	8066	8570	9200

* All weights are approximate with Base equipment and 24m boom

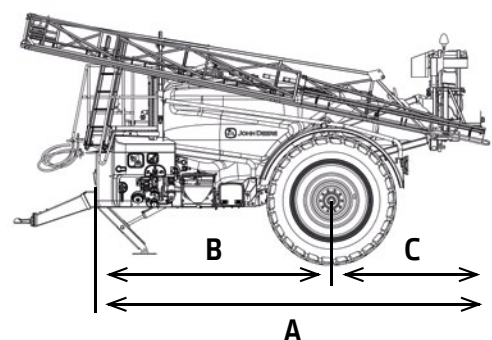
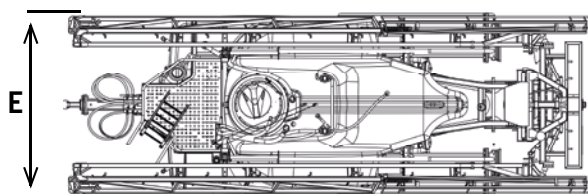
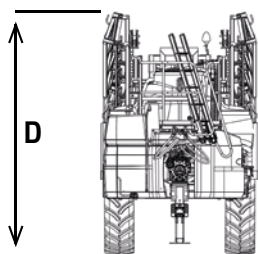

MEASUREMENTS IN CM						
Base sprayer	Spray boom	A	B	C	D	E
M944, M944i	36/24	763	507	256	365	300
M952, M952i	36/24	763	507	256	365	300
M962, M96i	36/24	763	507	256	365	300

*All measurements are approximate with tyres VF380/90R46 Overall machine height depends on boom adjustment.

SPECIFICATIONS SPRAYBOOM AND HYDRAULICS M900(i) SERIES	M900 SERIES	M900i SERIES
Boom height range* cm	200	200
Sprayboom material	Steel	Steel
Ball and socket bearings in swivel points with grease points	Base	Base
Stainless steel spray lines with quick-connect couplings	Base	Base
3 directional boom breakaway protection	Base	Base
Parallelogram, hydraulic height adjustment with a nitrogen pressure accumulator suspension and hydraulic transport lock	Base	Base
Centre frame with vertical and horizontal boom suspension and pendulum lock (anti yaw)	Base	Base
Endstroke dampening in hydraulic cylinders, boom folding cylinders between sprayboom segments	Base	Base
GPS section control ready	Base	Base
Selective control valve hydraulic operation for sprayboom, folding, height and tilt	Base	Base
Electro-hydraulic selector, operation for sprayboom, folding, height and tilt	Option	Option
Electro-hydraulic control including hydraulic oil filter for sprayboom, folding, height and tilt with auto center function and boom positioning indicator in display actual or pre-set position, and Optional steering axle and variable geometry	Option	Option
5 way nozzle bodies	Base	Base
Ringline liquid circulation trough section valves located in spray boom	Base	Base
Pressure circulation system full, liquid circulation through spraylines and liquid supply from both directions into spraylines in spray mode for fast and accurate pressure build-up	Option	Option
TwinSelect holds max. 5 nozzles, system controls 2 nozzles includes pressure circulation system full liquid circulation through spraylines and dual liquid supply in spray mode	Option	Option
Hydraulic flow requirements depend always on the selected options. Indication on minimum tractor hydraulic oil flow requirements with full options for sprayers without hydraulic pumpdrive; l/min	40	40

SPRAY BOOM M900(i) SERIES		
DOUBLE FOLD BOOMS	NO. OF SECTION	SECTION WIDTHS, M
24 / 12 m	4	6-6-6-6
24 / 12 m	6	4-4-4-4-4-4
24 / 12 m	8	3-3-3-3-3-3-3-3
27 / 15 m	9	3-3-3-3-3-3-3-3-3
28 / 14 m	7	4-4-4-4-4-4-4
28 / 14 m	8	3-4-4-3-3-4-4-3
30 / 15 m	9	3-4,5-3-3-3-3-3-4,5-3
TRIPLE FOLD BOOMS	NO. OF SECTION	SECTION WIDTHS, M
27 / 18 m	7	4,5-4,5-3-3-3-4,5-4,5
27 / 21 m	9	3-3-3-3-3-3-3-3-3
28 / 20 m	7	4-4-4-4-4-4-4
30 / 21 m	9	4,5-3-3-3-3-3-3-4,5
32 / 21 m	8	4-4-4-4-4-4-4-4
33 / 21 m	9	3-3-4,5-4,5-3-4,5-4,5-3-3
33 / 21 m	11	3-3-3-3-3-3-3-3-3-3-3
36 / 24 m	9	4-4-4-4-4-4-4-4-4
36 / 24 m	12	3-3-3-3-3-3-3-3-3-3-3-3
39 / 27 m	9	4,5-4,5-4,5-4,5-3-4,5-4,5-4,5-4,5
39 / 27 m	13	3-3-3-3-3-3-3-3-3-3-3-3-3
40 / 27 m	13	3,5-3-3-3-3-3-3-3-3-3-3-3,5

*All booms are available with ringline circulation, pressure circulation or TwinSelect

TYRE SIZES*	M944/M944i	M952/M952i	M962/M962i
Tyres mounted on fully welded rims (10 bolts)			
VF 380/90R46	available	available	available
480/80R46	available	available	available
520/85R38	available	available	available
520/85R42	available	available	available
520/85R46	available	available	available
620/70R42	available	available	available
710/70R38	available	available	n/a

*Selectable tire size is depending on machine type and axle load

NOTHING RUNS LIKE A DEERE.

Together with the John Deere dealership network, we are committed to keeping your operations up and running. We never stop investing in products and technologies that are quality-built, state-of-the-art and also dedicated to reducing operating costs.

Our effective dealer network – whose employees are all John Deere trained – is familiar with every nut,

bolt and byte in your equipment and skilled at diagnosing any potential problems.

You can count on your partnership with us and with our dealer network. After over 175 years in the farm equipment business, we can be sure that together we're better.

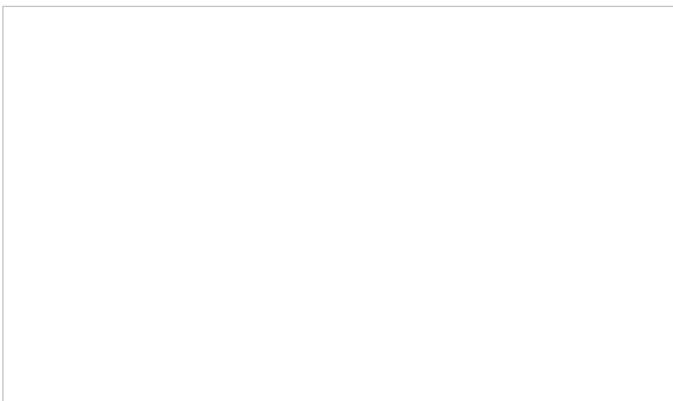

John Deere Financial – A range of finance options as powerful as our products. Contact your John Deere dealer for a comprehensive range of finance options to suit the specific needs of your business. Not available in all countries please consult your local dealer. This literature has been compiled for worldwide circulation. While general information, pictures and descriptions are provided, some illustrations and text may include finance, credit, insurance, product options and accessories not available in all regions. Please contact your local dealer for details. John Deere reserves the right to change specification and design of products described in this literature without notice. The green and yellow color scheme, the leaping deer logo and the JOHN DEERE word mark are trademarks of Deere & Company.

JohnDeere.com