

## Safety and operating instructions

### Hydraulic breakers

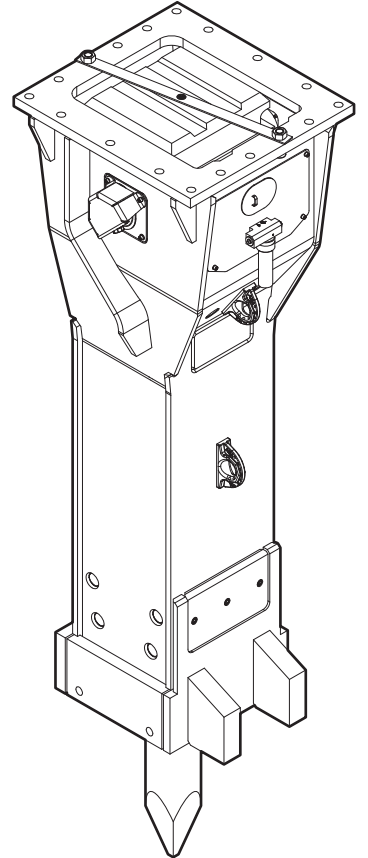



# Contents

<b>INTRODUCTION</b> .....	7
<b>About these Safety and Operating Instructions</b> .....	7
<b>SAFETY INSTRUCTIONS</b> .....	9
<b>Signal words</b> .....	9
<b>Qualification</b> .....	10
<b>Intended use</b> .....	10
<b>Use other than intended</b> .....	10
<b>Protective equipment</b> .....	10
<b>Transport, precautions</b> .....	11
<b>Hydraulic installation, precautions</b> .....	11
<b>Special parts, precautions</b> .....	11
HP-accumulator .....	11
Piston accumulator .....	11
<b>Media/consumables, precautions</b> .....	12
<b>Explosion and fire, precautions</b> .....	12
<b>Electrical shock, precautions</b> .....	12
<b>Falling stones, precautions</b> .....	13
<b>Emissions, precautions</b> .....	13
<b>Handling machines, precautions</b> .....	13
<b>Repair, precautions</b> .....	13
<b>Changes to the hydraulic attachment, precautions</b> .....	13
<b>Environmental pollution, precautions</b> .....	14
<b>OVERVIEW</b> .....	15
<b>Equipment description</b> .....	15
<b>Function</b> .....	16
<b>Signs / labels</b> .....	17
Name plate .....	17
Labels .....	18
<b>Signs</b> .....	18
<b>Applications</b> .....	18
<b>Guarantee</b> .....	18
<b>Removing the packaging</b> .....	19
<b>Scope of delivery</b> .....	19
<b>TRANSPORT</b> .....	20
<b>Transport using a crane</b> .....	20
<b>Transport using a forklift truck</b> .....	21
<b>Transport using a truck</b> .....	21
<b>INSTALLATION</b> .....	22
<b>Media/consumables</b> .....	22
Mineral hydraulic oil .....	22
Non-mineral hydraulic oil .....	22
Grease .....	22
Gas .....	22
<b>Manufacturing the adapter plate</b> .....	23
<b>Installing the adapter plate</b> .....	23
<b>Attaching the hydraulic attachment to the carrier</b> .....	24
Mechanical mounting aspects .....	24
Making the hydraulic connections .....	25
<b>Removing the hydraulic attachment from the carrier</b> .....	27
Dismantling the hydraulic connections .....	27
Mechanical disassembly .....	27

<b>Removing the adapter plate</b> .....	27
<b>DustProtector</b> .....	28
Removal.....	28
Installation.....	28
<b>Working tool</b> .....	29
Selecting the right working tool.....	29
Installation.....	30
Removal.....	31
<b>OPERATION</b> .....	32
<b>Preparations before starting</b> .....	32
<b>Switching the hydraulic breaker on and off</b> .....	33
<b>Functional test</b> .....	33
<b>Correct operation</b> .....	33
Working angle.....	33
Advance.....	34
Impact time.....	34
High ambient temperature.....	34
Low ambient temperature.....	34
<b>Prohibited operation</b> .....	35
Lifting/Transporting.....	35
Impacting.....	35
Moving objects.....	35
Levering.....	35
Blank firing of the working tool.....	36
Cylinder end positions.....	36
<b>Working with safety equipment</b> .....	37
Underwater applications.....	37
Usage in tunnels.....	37
Hot applications.....	37
<b>AutoControl System</b> .....	37
AutoControl in daily use.....	37
AutoControl in special applications.....	37
<b>StartSelect System AutoStart/AutoStop</b> .....	38
Switching between AutoStart/AutoStop.....	38
<b>PowerAdapt</b> .....	40
<b>MAINTENANCE</b> .....	41
<b>Maintenance schedule</b> .....	42
<b>Depressurising the hydraulic system</b> .....	43
<b>Cleaning</b> .....	44
Preparations.....	44
Procedure.....	44
<b>Lubrication</b> .....	44
Checking the lubricant film.....	44
Automatic lubrication.....	45
Replacing the lubricant cartridge.....	45
ContiLube® II operation.....	45
Manual lubrication.....	46
Chisel paste filling device.....	46
<b>Checking the tensioning bolts</b> .....	47
<b>Checking the working tool</b> .....	47
<b>Checking the retainer bars</b> .....	48
<b>Checking the percussion piston impact surface</b> .....	48
<b>Checking the wear bushes and impact ring</b> .....	48
<b>Checking and cleaning the DustProtector system</b> .....	49
<b>Piston accumulator</b> .....	50
Checking the pressure in the piston accumulator.....	51
Release the pressure from the piston accumulator.....	52
Filling/topping up the piston accumulator.....	52

<b>HP-accumulator</b> .....	53
Checking the expansion bolts .....	53
Checking the gas pressure .....	53
<b>Checking the hydraulic lines</b> .....	53
<b>Checking and cleaning the hydraulic oil filter</b> .....	53
<b>Checking the adapter plate and the breaker box for cracks and/or wear</b> .....	54
<b>Checking the adapter plate bolts for wear</b> .....	54
<b>Bolt connections/Tightening torques</b> .....	55
<b>TROUBLESHOOTING</b> .....	59
<b>The hydraulic breaker does not start</b> .....	59
<b>Hydraulic breaker operates too slowly</b> .....	60
<b>Impact force too low</b> .....	60
<b>Impact rate too high and impact force too low</b> .....	60
<b>Oil leaks from ports »P« und »T«</b> .....	61
<b>Oil escapes between the cylinder cover and the cylinder</b> .....	61
<b>Oil escapes from parts of the hydraulic breaker installation (connecting fittings, hoses etc.)</b> .....	61
<b>Oil escapes from the working tool</b> .....	61
<b>Oil escapes from the high pressure accumulator</b> .....	61
<b>Oil or grease escapes from the ContiLube® II</b> .....	61
<b>Operating temperature too high</b> .....	62
<b>REPAIR</b> .....	63
<b>Sending in the hydraulic attachment for repairs</b> .....	63
<b>STORAGE</b> .....	64
<b>Hydraulic breaker</b> .....	64
Short storage .....	64
Long storage .....	64
How to proceed after more than twelve months' storage .....	64
<b>Working tool</b> .....	65
<b>Grease cartridges</b> .....	65
<b>DISPOSAL</b> .....	66
<b>Hydraulic breaker</b> .....	66
<b>Hydraulic hoses</b> .....	66
<b>Hydraulic oil</b> .....	66
<b>Chisel paste and grease cartridges</b> .....	66
<b>TECHNICAL SPECIFICATIONS</b> .....	67
<b>Noise declaration statement</b> .....	67
<b>EC Declaration of Conformity (EC Directive 2006/42/EC)</b> .....	69



# INTRODUCTION

Thank you for choosing an Atlas Copco product! We have been working according to a customer-oriented approach since 1873. Our innovative and ergonomic solutions help our customers lower costs and achieve better business results.

Atlas Copco has a worldwide, comprehensive sales and service network of Customer Centers and dealers. Our professionals are specialists with a thorough product knowledge and considerable application experience.

This allows us to offer our customers effective service and know-how throughout the world, enabling them to achieve greater operating efficiency.

Atlas Copco Construction Tools GmbH  
P.O. Box: 102152  
Helenenstraße 149  
D - 45021 Essen  
Tel.: +49 201 633-0

## About these Safety and Operating Instructions

The aim of these Instructions is to familiarise you with the safe and effective operation of the hydraulic attachment. You will also find instructions for regular maintenance activities for the hydraulic attachment in this document.

Please read these Instructions carefully prior to the first attachment and use of the hydraulic attachment.

In these instructions, the DustProtector version of the hydraulic breaker will be referred to by the abbreviation DP.

The different designation of the texts means as follows:

- |    |  |
|----|--|
| ▶  | Action step in a safety instruction      |
| ◆  | Action step                              |
| 1. | Established operation process            |
| 2. |  |
| A  | Explanation of the elements of a drawing |
| B  |  |
| C  |  |
| •  | Listing                                  |
| •  |  |
| •  |  |

Symbols used in illustrations have the following meanings:



permitted operation



prohibited operation



# SAFETY INSTRUCTIONS

**▲** This is the safety alert symbol. It is used to alert you to potential personal injury hazards. Obey all safety messages that follow this symbol to avoid possible injury or death.

**▲** Read these Safety and operating instructions and specifically all safety instructions before using the hydraulic attachment. This will:

- prevent the risk of injuries and fatal accidents for yourself and others,
- protect the hydraulic attachment and other property against material damage,
- protect the environment against environmental damage.

Follow all instructions in these Safety and operating instructions.

Store these Safety and operating instructions in the document compartment of the carrier cab.

Anyone

- transporting,
- installing or removing,
- operating,
- maintaining,
- repairing,
- storing or
- disposing of

the hydraulic attachment must have read and understood these Safety and operating instructions.

These Safety and operating instructions belong to the hydraulic attachment. Keep it for the life of the product. Ensure, if applicable, that any received amendment is incorporated in the instructions. Hand over the Safety and operating instructions if ever you lend, rent out or sell the hydraulic attachment.

All safety regulations listed in this manual comply with the laws and regulations of the European Union. Also observe the additional national/regional regulations.

Hydraulic attachment operation outside the European Union is subject to the laws and regulations valid in the country of use. Please observe any other, more stringent regional regulations and legislation.

Read the carrier manufacturer's Safety and operating Instructions before attaching the hydraulic attachment to the carrier and operating it. Observe all instructions.

## Signal words

The signal words Danger, Warning, Caution, and Notice are used as follows in these Safety and operating instructions:

<b>DANGER</b>	indicates a hazardous situation which, if not avoided, will result in death or serious injury.
<b>WARNING</b>	indicates a hazardous situation which, if not avoided, could result in death or serious injury.
<b>CAUTION</b>	indicates a hazardous situation which, if not avoided, could result in minor or moderate injury.
<b>NOTICE</b>	The signal word NOTICE is used to address practices related to possible property damage but not related to personal injury.

## Qualification

---

**Transporting** the hydraulic attachment is only permitted if carried out by people who:

- are authorised to operate a crane or a forklift truck according to the applicable national provisions,
- know all the relevant national/regional safety provisions and accident prevention rules,
- have read and understood the safety and transport chapter of these Safety and operating instructions.

**Installing, maintaining, storing and disposing** of the hydraulic attachment are only permitted if carried out by people who:

- know all the relevant national/regional safety provisions and accident prevention rules,
- have read and understood these Safety and operating instructions.

**Operating** the hydraulic attachment is only permitted if carried out by qualified carrier drivers. Carrier drivers are qualified if they:

- have been trained to operate a carrier according to the national regulations,
- know all the relevant national/regional safety provisions and accident prevention rules,
- have read and understood these Safety and operating instructions.

**Testing the hydraulic installation** is only permitted if carried out by professionals. Professionals are people who are authorised to approve a hydraulic installation for operation according to the national regulations.

**Repairing** the hydraulic attachment is only permitted if carried out by professionals trained by Atlas Copco Construction Tools. These professionals must have read and understood these Safety and operating instructions. They must follow all safety instructions and guidelines for repair. Otherwise the operational safety of the hydraulic attachment is not guaranteed.

## Intended use

---

Only attach the hydraulic breaker to a hydraulic carrier of a suitable load-bearing capacity.

Only use the hydraulic breaker function of the device to break or fragment concrete, stone and rocks.

Using the hydraulic breaker in and under water, in tunnels, under the ground and for hot applications is only possible if it has been fitted out with special safety equipment.

Intended use also implies observing all instructions in these Safety and operating instructions.

## Use other than intended

---

Never operate the hydraulic breaker in an environment where there is a risk of explosions. Explosions will result in serious injury or death.

Never use the hydraulic breaker

- to transport or lift objects.  
The lifted object can fall and cause serious injuries or death.
- as a sledge hammer.  
This will damage the hydraulic breaker, the working tool and the carrier.
- as a crowbar.  
This can cause the working tool to break.
- to push debris  
This damages the hydraulic breaker.

## Protective equipment

---

Personal protective equipment must comply with the applicable health and safety regulations.

Always wear the following personal protective equipment:

- protective helmet
- safety glasses with side protectors
- protective gloves
- protective shoes
- warning vest
- hearing protection

## Transport, precautions

### ▲ WARNING Falling carrier

If the load-bearing capacity of the carrier used is insufficient, the carrier will not be stable. It can topple over and cause injuries and damage.

Using a carrier whose load-bearing capacity is too high will greatly burden the hydraulic attachment causing it to wear faster.

- ▶ Only attach the hydraulic attachment to a hydraulic carrier of a suitable load-bearing capacity.
- ▶ The carrier must remain stable at all times.
- ▶ Read the carrier manufacturer's Safety and operating Instructions before attaching the hydraulic attachment to the carrier and operating it. Observe all instructions.

## Hydraulic installation, precautions

### ▲ WARNING Hydraulic pressure too high

If the hydraulic pressure is too high, the parts of the hydraulic attachment will be exposed to excessively high loads. Parts can break loose or burst causing serious injuries.

- ▶ Lay the drain line of the pressure relief valve directly in the tank to ensure the safe functioning of the pressure relief valve!
- ▶ The pressure relief valve must be set at the maximum static pressure.
- ▶ The pressure relief valve setting must be checked to ensure that the maximum static pressure (see chapter *Technical specifications*) of the hydraulic installation is not exceeded at any time. Attach a lead seal to the pressure relief valve.
- ▶ Prior to their first use, the safety facilities on the hydraulic installation must be checked by a professional/authorised monitoring body for their quality (CE mark etc.), suitability and proper functioning.
- ▶ If any significant changes are made to the hydraulic installation, a new acceptance inspection is to be carried out in accordance with the relevant national safety provisions.

### ▲ WARNING Hot hydraulic oil squirting out

The hydraulic system is under high pressure. Hydraulic lines may spring a leak or burst. Hydraulic oil squirting out can lead to serious injury.

- ▶ When attaching the hydraulic attachment do not lay any hydraulic lines through the carrier's cab.
- ▶ Only use hydraulic lines which comply with the following quality requirements:  
Hydraulic hoses with 4 reinforcement steel wires according to DIN EN 856 4SH,  
Hydraulic pipes, seamless cold-drawn steel pipes to DIN EN 10305.

## Special parts, precautions

### HP-accumulator

#### ▲ DANGER Danger of explosions

The HP-accumulator of the hydraulic breaker is filled with nitrogen (N<sub>2</sub>). Filling it with any other gas may trigger an explosion and lead to serious, possibly fatal, injuries.

- ▶ Only fill the HP-accumulator with nitrogen (N<sub>2</sub>).
- ▶ Do not carry out any welding and soldering work to the HP-accumulator.
- ▶ Check the HP-accumulator in accordance with the national safety provisions.

#### ▲ WARNING Component coming loose abruptly Risk of bursting

The HP-accumulator is under pressure, even when the hydraulic system has been depressurised. Screw connections might come loose unexpectedly and cause injuries.

- ▶ Never unscrew the cover or the upper shell from a pressurised HP-accumulator.
- ▶ Never carry out mechanical processing to the HP-accumulator.

### Piston accumulator

#### ▲ DANGER Danger of explosions

The integrated piston accumulator is filled with nitrogen (N<sub>2</sub>). Filling it with any other gas may trigger an explosion and lead to serious, possibly fatal, injuries.

- ▶ Only fill the piston accumulator with nitrogen (N<sub>2</sub>).

**▲ WARNING Component coming loose abruptly**

The piston accumulator is under pressure, even when the hydraulic system has been depressurised. The filling valve might come loose unexpectedly and cause injuries.

- ▶ Never unscrew the filling valve »G« from the pressurised piston accumulator.

## Media/consumables, precautions

---

**▲ WARNING Hot hydraulic oil under high pressure**

Hydraulic oil will squirt out under high pressure if there is a leakage. The jet of oil might penetrate people's skin and cause permanent damage. Hot hydraulic oil can cause burns.

- ▶ Never use your hands to find leaks.
- ▶ Always keep your face away from a possible leak.
- ▶ If hydraulic oil has penetrated your skin consult a doctor immediately.

**▲ WARNING Hydraulic oil spills**

Spilt hydraulic oil can make a floor slippery. If people slip they can be injured. Hydraulic oil is environmentally harmful and must not penetrate the ground or enter the water table or water supplies.

- ▶ Make sure not to spill any hydraulic oil.
- ▶ Immediately clean the floor if you have spilt hydraulic oil.
- ▶ Observe all safety and environmental protection provisions when handling hydraulic oil.

**▲ WARNING Skin infections/diseases due to oil and grease**

Hydraulic oil and grease can cause rashes (or even eczema) if they come into contact with the skin.

- ▶ Avoid all skin contact with hydraulic oil and grease.
- ▶ Use a suitable skin protection product.
- ▶ Always wear safety gloves when working with hydraulic oil or grease.
- ▶ Immediately clean any skin that has been contaminated by oil or grease with water and soap.

## Explosion and fire, precautions

---

**▲ DANGER Explosion and fire**

Explosions cause serious injury or death.

If the working tool hits explosives, an explosion may be the result.

- ▶ Never operate the hydraulic breaker in the direct vicinity of explosives.
- ▶ Make sure that no explosives are hidden in the rocks and stones.
- ▶ Check gas line position plans of the entire construction area.

**▲ DANGER Explosion and fire**

Operating the hydraulic breaker may create sparks which ignite highly flammable gases. This may lead to fire or an explosion.

- ▶ Never work in an environment with highly flammable substances.
- ▶ Make sure that there are no hidden sources of gas in the work area.
- ▶ Check gas line position plans of the entire construction area.

**▲ DANGER Explosion and fire**

Dust-rich air can form an explosive atmosphere which may ignite when operating the hydraulic breaker. This may lead to fire or an explosion.

- ▶ Never use the hydraulic breaker in an explosive atmosphere.
- ▶ Always provide sufficient ventilation when working in buildings or in a confined area.

## Electrical shock, precautions

---

**▲ DANGER Electrical shock**

Any contact of the hydraulic attachment with electric circuits or other sources of electricity will lead to an electric shock, resulting in serious injury or death. The hydraulic attachment is not electrically insulated.

- ▶ Never work in the vicinity of electric circuits or other sources of electricity.
- ▶ Make sure that there are no hidden circuits in the work area.
- ▶ Check wiring diagrams.

## Falling stones, precautions

### ▲ WARNING Fragments flying around

Fragments of material which come loose while operating the hydraulic attachment may be flung away and can cause serious injury if people are hit by them. Small objects falling from a great height can also cause serious damage.

During hydraulic attachment operation the danger zone is considerably greater than during the excavation operation due to fragments of stone and pieces of steel flying around, and for this reason the danger zone must, depending on the type of material to be worked on, be enlarged correspondingly, or secured in a suitable manner through corresponding measures.

- ▶ Secure the danger zone.
- ▶ Stop the hydraulic attachment immediately if anyone enters the danger zone.
- ▶ Close the windscreen and the side windows of the driver's cab.

## Emissions, precautions

### ▲ WARNING Noise hazard

Operating the hydraulic attachment creates a loud noise. Long term high sound pressure level can affect your hearing.

- ▶ Wear suitable hearing protection.

### ▲ WARNING Lung disease

Dust may be generated when operating the hydraulic attachment. If dust from rocks or silica dust, produced when operating the hydraulic attachment on rocks, concrete, asphalt or other such materials, is inhaled this may lead to silicosis (dust lungs, a severe lung disease). Silicosis is a chronic disease which may lead cancer and death.

- ▶ Wear a suitable breathing mask.

## Handling machines, precautions

### ▲ WARNING Narcotics, alcohol and drugs

Narcotics, alcohol and medicinal drugs make their users less alert and affect their ability to concentrate. Negligence and incorrectly assessing a situation can result in serious injury or death.

- ▶ Never work on or with the hydraulic attachment when under the influence of narcotics, alcohol or drugs which affect your alertness.
- ▶ Never allow other people who are under the influence of narcotics, alcohol or drugs which affect their alertness to work on or with the hydraulic attachment.

## Repair, precautions

### ▲ WARNING Heavy parts falling

The main parts of the hydraulic breaker are heavy. Unsuitable lifting attachments (e.g. ring or eye bolts) may fail and cause heavy parts to fall. Falling parts may cause serious injury.

- ▶ Never pull the percussion unit out of the breaker box. Dismounting the percussion unit is only permitted if carried out by professionals trained by Atlas Copco Construction Tools. These professionals must follow all safety instructions and guidelines for repair.
- ▶ These professionals are only permitted to repair the percussion unit if they use the sling gears prescribed by Atlas Copco Construction Tools when:
  - removing the complete percussion unit.
  - mounting or dismounting parts of the percussion unit.

## Changes to the hydraulic attachment, precautions

### ▲ WARNING Changes to the hydraulic attachment

Changes to the hydraulic attachment or the adapter plate may lead to serious injury.

- ▶ Never carry out any changes to the hydraulic attachment or the adapter plate.
- ▶ Only use original parts or accessories approved by Atlas Copco.
- ▶ Modifications that entail new hazards may require a new procedure for assessing conformity.

**▲ WARNING Changes to the HP-accumulator**

Changes to the HP-accumulator may lead to serious injury.

- ▶ Never carry out any changes to the HP-accumulator.
- ▶ Any modification will result in immediate invalidation of the operating licence.

## Environmental pollution, precautions

---

*NOTICE* Environmental pollution due to hydraulic oil

Hydraulic oil is permanently environmentally harmful. Escaped hydraulic oil will lead to groundwater and soil contamination. Organisms may die.

- ▶ Collect any hydraulic oil which escapes to avoid environmental pollution. For minor volumes use an absorbing medium (in case of an emergency use soil). In case of major leakages contain the hydraulic oil. It must not drain off and penetrate the ground or enter the water table or water supplies.
- ▶ Collect contaminated absorbing medium or soil in a watertight box/container and close it tight.
- ▶ Contact an authorized waste management company.
- ▶ Dispose of all contaminated material in accordance with the applicable environmental regulations.

# OVERVIEW

## Equipment description

The picture gives an overview of the main parts and components of the hydraulic attachment. Actual details may differ.

HB 5800/DP

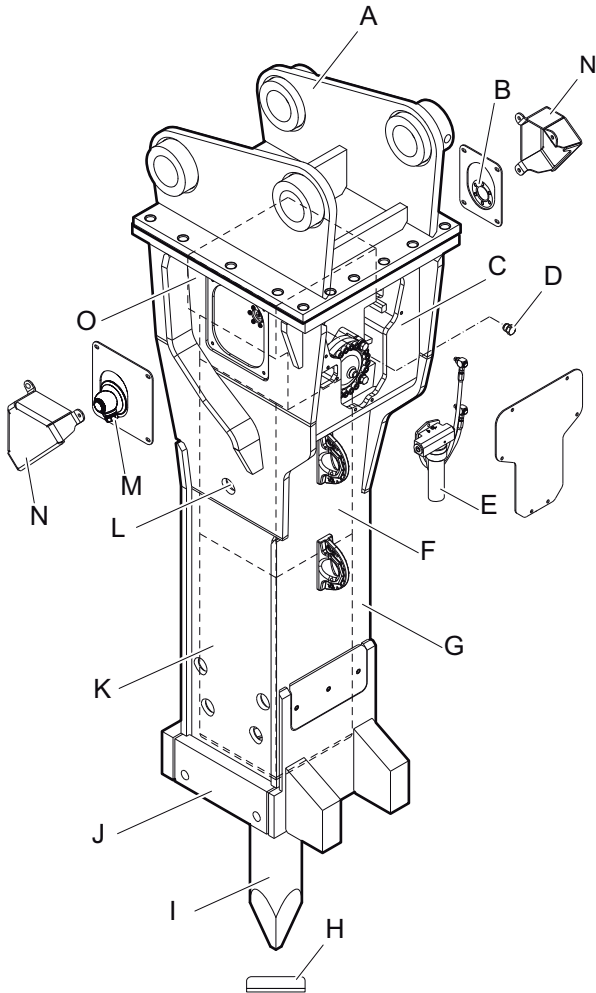

HB 7000/DP

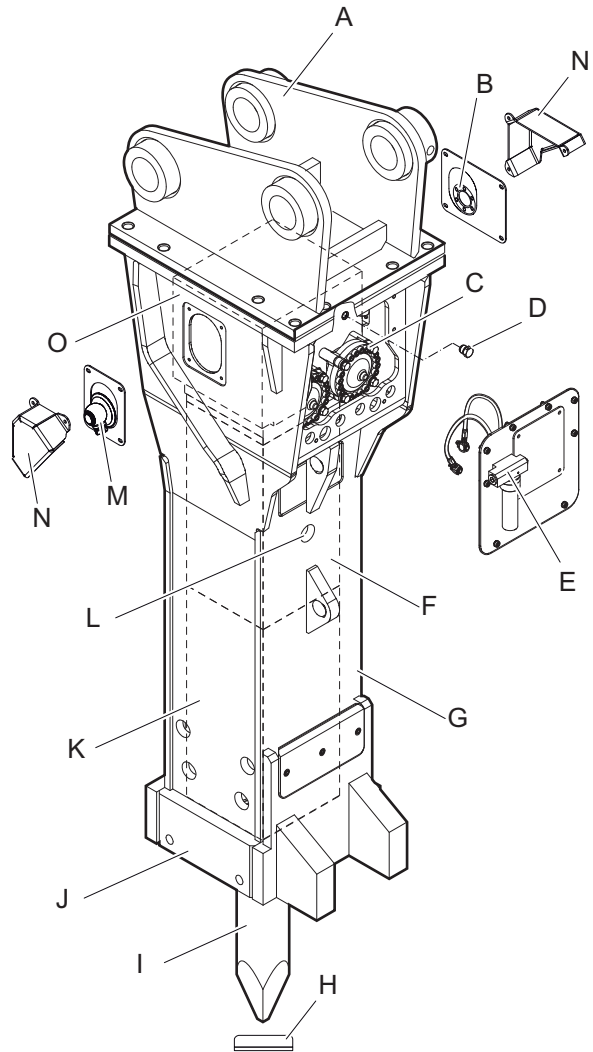

HB 10000/DP

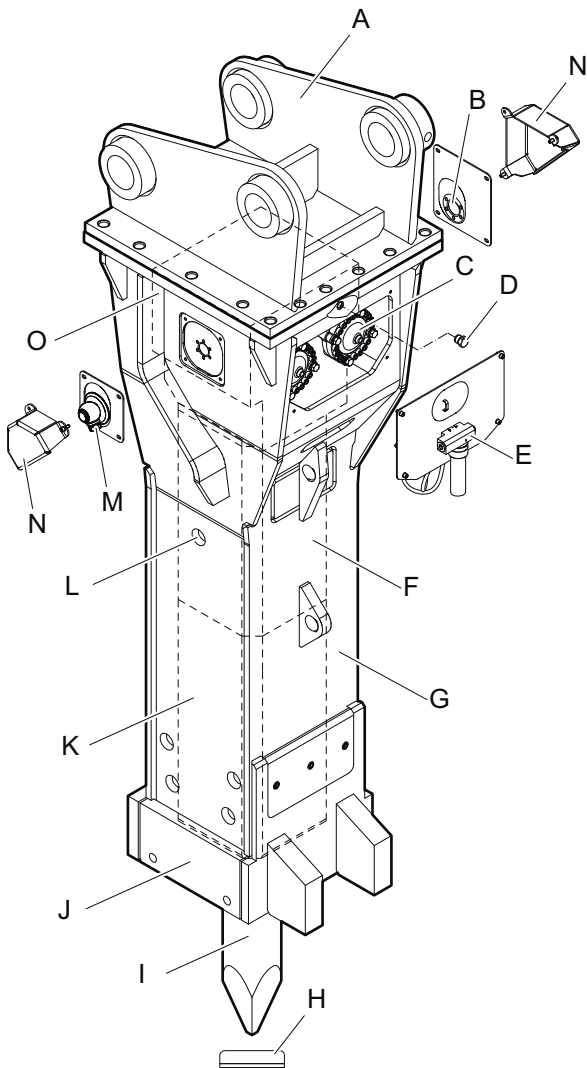

- J. The **DustProtector system** prevents dust from entering the percussion compartment (only on the DP version).
- K. The working tool is retained in the **lower breaker part**.
- L. **StartSelect** valve
- M. Pressure line »P«
- N. The **swivel joint covers** protect the swivel joints.
- O. The **cylinder cover** houses the nitrogen gas (N<sub>2</sub>) filled piston accumulator and the control mechanism.

## Function

The operation of a hydraulic breaker is described in a greatly simplified version below:

The pressure line »P« supplies oil at the operating pressure of the carrier to the hydraulic breaker. The tank line »T« returns the oil to the tank of the carrier. The HP-accumulator compensates pressure variations in the hydraulic system.

The percussion piston moves up and down in the cylinder. When the percussion piston is in its lower position, it impacts the working tool. The percussion energy is transferred to the material to be broken via the working tool.

- A. The hydraulic breaker is connected to the carrier by the **adapter plate**. The adapter plate is not included in the scope of supply of the hydraulic breaker.
- B. Tank line »T«
- C. The **HP-accumulator** compensates pressure variations in the hydraulic system.
- D. **Non-return valve** of percussion compartment ventilation
- E. Automatic lubrication system **ContiLube® II**
- F. The percussion piston is guided in the **cylinder**.
- G. The **breaker box** protects the percussion unit.
- H. Working tool aperture **protective cap**
- I. The **working tool** can be replaced as required. The working tool is not included in the scope of supply of the hydraulic breaker.



## Signs / labels

### ▲ WARNING Missing warnings

The name plate and the labels on the hydraulic attachment contain important information about the hydraulic attachment and for personal safety. A missing warning can cause personal hazards. The signs and labels must always be clearly legible.

- ▶ Immediately replace any defective name plates and labels.
- ▶ Use the spare parts list to order new name plates and labels.

### Name plate

Product group A:

Percussion unit (without breaker box)

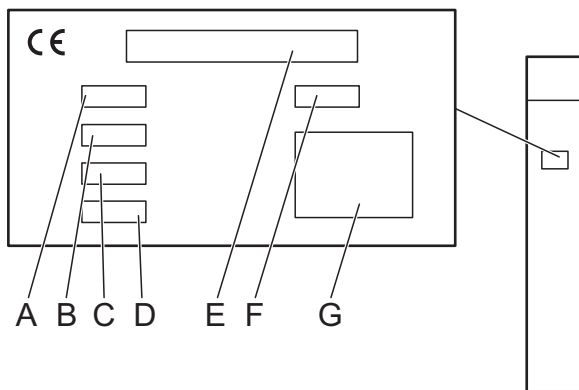

Product group B:

Hydraulic breaker (percussion unit with breaker box)

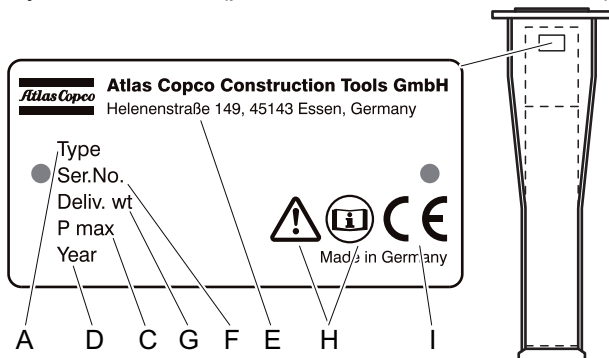

- A. Model
- B. Part number
- C. Max. permissible operating pressure
- D. Year of manufacture of product group
- E. Name and address of manufacturer
- F. Serial number
- G. Weight of product group

- H. The warning symbol and the book symbol indicate that the Safety and Operating Instructions must be read prior to use of the hydraulic attachment and in particular the chapter on Safety.
- I. The CE symbol indicates that the hydraulic attachment was produced in conformity with CE. You can find further information about this in the enclosed EC Declaration of Conformity.

Labels

Sound Power

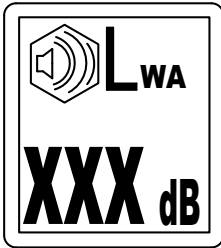

The label states the guaranteed sound power level in accordance with EC directive 2000/14/EC.

Transport warning



Never lift the hydraulic breaker by the transport safety device. This was not designed for lifting and might break, causing the hydraulic breaker to fall

Lubrication symbol

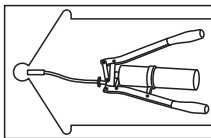

The label identifies a lubrication point.

Gas pressure

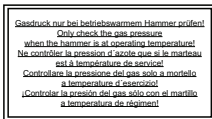

The label indicates that the gas pressure can only be checked if the breaker has reached operating temperature.

Signs



The warning symbol and the book symbol indicate that the Safety and Operating Instructions must be read prior to use of the hydraulic attachment and in particular the chapter on Safety.

Applications

Field

General construction work

Demolition

Rock mining/breaking

Tunneling\*, mining\*

High temperature applications\*

Underwater applications\*

Type of application

Trenchwork for utilities, foundation work

Heavily reinforced concrete, demolition of power stations and bridges

Primary breaking

Secondary breaking, bench leveling foundation work

Bench levelling

Tunnel driving

Breaking up slag

Demolition, Deepening shipping channels

\* only after consulting the Atlas Copco Customer Center/Dealer in your area

Guarantee

The guarantee or product liability will be invalidated by the following:

- Use other than intended
- Maintenance work not being carried out or being carried out incorrectly
- The use of the wrong consumables
- The use of non-approved parts
- Damage due to wear
- Special applications without the required safety facilities
- Damage due to improper storage
- Changes not carried out by or in consultation with the manufacturer

## Removing the packaging

---

- ◆ Remove all the packaging material.
- ◆ Dispose of it in accordance with the applicable provisions.
- ◆ Check that the delivery is complete.
- ◆ Check the delivery for visual damage.
- ◆ If any defects are found, consult the Atlas Copco Customer Center/dealer in your area.

## Scope of delivery

---

The hydraulic breaker is delivered complete with:

- Hydraulic breaker
- Test gauge lower wear bush
- Safety and Operating instructions
- Spare parts list
- EC Declaration of Conformity

Accessories as ordered:

- Working tool
- Hoses
- Service box

Special accessories as ordered:

- e.g. adapter plate with Allen screws and pairs of lock washers
- e.g. base plate to construct an adapter plate with Allen screws and pairs of lock washers
- e.g. hydraulic fittings for the carrier
- e.g. piston retainer
- e.g. calliper upper wear bush

# TRANSPORT

**▲ WARNING Hoist tipping over / hydraulic attachment falling**

The hydraulic attachment is heavy. The hoist/lifting equipment and/or hydraulic attachment tipping over or falling may cause serious injury and material damage.

- ▶ Only transport the hydraulic attachment with lifting equipment with the right load-bearing capacity for the weight of the hydraulic attachment.
- ▶ Only lift and secure the hydraulic attachment with lifting gear (ropes, chains, shackles etc.) with the right load-bearing capacity for the weight to be lifted.
- ▶ Make sure that there is nobody near or under the suspended hydraulic attachment.

**▲ WARNING Hydraulic breaker falling**

The lifting eye may fail and cause the hydraulic breaker to fall. This may cause serious injury and material damage.

- ▶ Check the lifting eye before you lift the hydraulic breaker. Never lift the hydraulic breaker with the lifting eye if:
  - the checkpoints (A) are worn and not protruding anymore
  - or
  - the checkpoints (B) are worn and not recessed anymore.

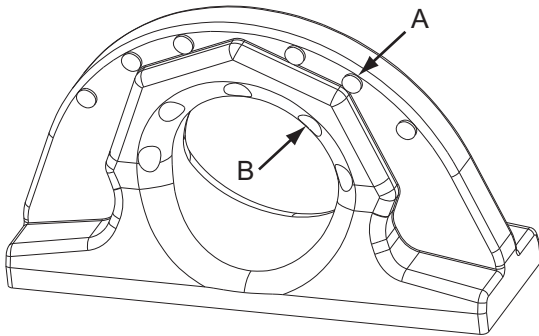

- the lifting eye is bent.
- you detect cracks in the lifting eye or the weld seam.
- ▶ Contact the Atlas Copco Customer Center/Dealer in your area if the lifting eye is worn in any way.

# Transport using a crane

- ◆ Secure the hydraulic attachment with ropes or chains as shown in the following illustration.

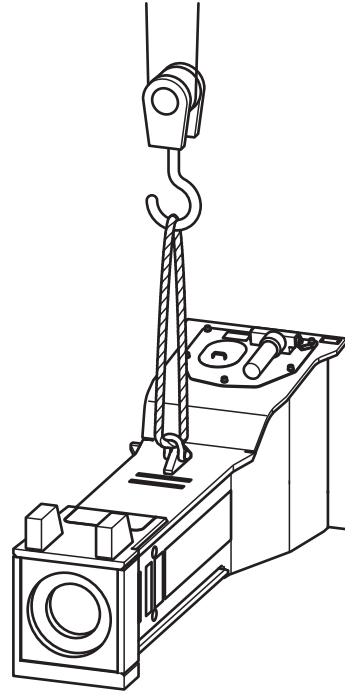

- ◆ Slowly lift the hydraulic attachment.
- ◆ Place the hydraulic attachment on timber support blocks.

## Transport using a forklift truck

### ▲ WARNING Hydraulic attachment tipping over

The hydraulic attachment tipping over and falling from the fork of the forklift truck may cause serious injury.

- ▶ Move the fork of the forklift truck under the hydraulic attachment so that the centre of gravity is between the prongs.

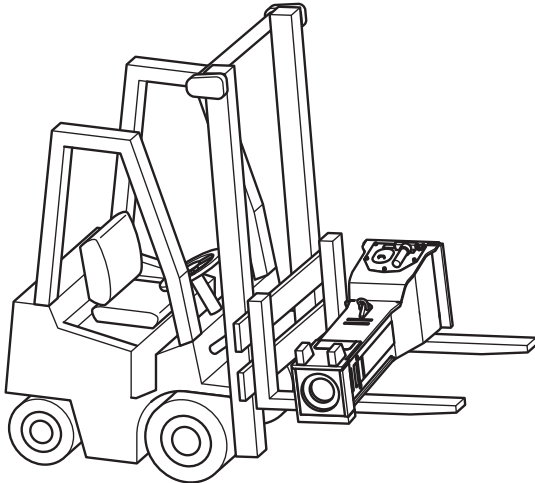

- ◆ Slowly lift the hydraulic attachment.
- ◆ Transport the hydraulic attachment to its intended destination.
- ◆ Place the hydraulic attachment on timber support blocks.

## Transport using a truck

### ▲ WARNING Hydraulic attachment tipping over / slipping

The hydraulic attachment slipping or tipping over and falling from the loading surface of a lorry may cause serious injury.

- ▶ Put the hydraulic attachment on an anti-slip mat.
- ▶ Secure the hydraulic attachment to the loading surface with ropes or chains; use any available transport lugs.
- ◆ Secure the hydraulic attachment to the loading surface as shown in the following illustration.
- ◆ Observe all the applicable national/regional regulations on securing loads.

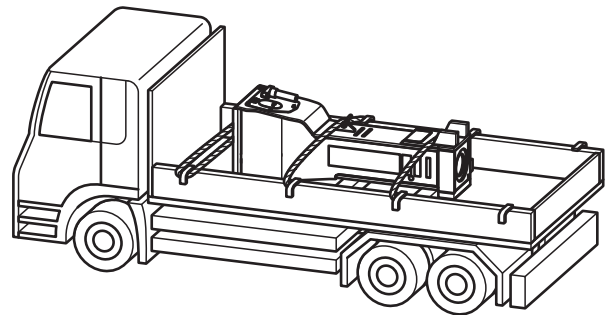

# INSTALLATION

## ▲ WARNING Hot hydraulic oil squirting out

The hydraulic system is under high pressure. If hydraulic connections come loose or are disconnected, hydraulic oil will squirt out under high pressure. Hydraulic oil squirting out can lead to serious injury.

- ▶ Depressurise the hydraulic system before connecting or disconnecting the hydraulic circuits of the hydraulic attachment (see chapter *Depressurising the hydraulic system*).

**NOTICE** Environmental damage due to hydraulic oil

Hydraulic oil is environmentally harmful and must not penetrate the ground or enter the water table or water supplies.

- ▶ Collect any hydraulic oil which escapes.
- ▶ Dispose of it in accordance with the applicable environmental regulations.

## Media/consumables

The following consumables are used when operating the hydraulic attachment:

### Mineral hydraulic oil

All hydraulic oil brands prescribed by the carrier manufacturer are also suitable for use when operating the hydraulic attachment.

However, the oil should comply with viscosity class HLP 32 or higher.

In summer and in hot climates, oils of viscosity class HLP 68 or higher should be used.

In all other respects the regulations of the carrier manufacturer are to be taken into consideration.

Optimum viscosity range	= 30 - 60 cSt
Max. start viscosity	= 2000 cSt
Max. oil temperature	= 80 °C

Special conditions apply to using the hydraulic attachment at low temperatures (see chapter *Low ambient temperature*).

- ◆ Check the oil filter!

An oil filter must be integrated in the tank line of the hydraulic system. The maximum mesh width allowed for the oil filter is 50 microns; it must have a magnetic separator.

## Non-mineral hydraulic oil

**NOTICE** Mixed hydraulic oil

Never mix mineral and non-mineral hydraulic oils! Even small traces of mineral oil mixed in with non-mineral oil can result in damage to both the hydraulic attachment and the carrier. Non-mineral oil loses its biodegradability.

- ▶ Only use one type of hydraulic oil.

If you are using non-mineral oil it is imperative that the name of the oil in use be indicated when returning the hydraulic attachment for repair.

In order to protect the environment or on technical grounds, hydraulic oils are currently being used which are not classified as HLP mineral oils.

Before using hydraulic oils of this kind it is imperative to ask the carrier manufacturer whether operations with such fluids are possible.

Our hydraulic attachments are basically designed for use with mineral oils. Consult the Atlas Copco Customer Center/Dealer in your area before using other hydraulic oils approved by the carrier manufacturer. Following initial assembly and after any workshop repairs, our hydraulic attachments are subjected to a test run on a test bed powered by **mineral oil**.

## Grease

- ◆ When handling oils and greases observe the safety instructions that apply to these products.

Media /consumables	Part number
Chisel paste (for ContiLube® II)	3363 0912 00
Parker O-Lube	3363 0852 30

## Gas

Normal nitrogen, purity degree 99.8 %

Media /consumables	Part number
Nitrogen bottle 2 l	3363 0345 04
Nitrogen bottle 5 l	3363 0345 06

## Manufacturing the adapter plate

Atlas Copco Construction Tools also supplies base plates to manufacture adapter plates alternatively to the adapter plates supplied.

### NOTICE Adapter plate cracking

The adapter plate may crack if it is not designed for the high load.

- ▶ Take not only the weight of the hydraulic attachment but also the crowd force of the carrier, possible vibration etc. into account when dimensioning the adapter plate.
- ▶ Ensure that the design conforms to the state of the art.
- ▶ Have the web plates welded to the adapter plate base plate by a qualified welding specialist.

The base plate is made of the material EN10025-S355 J2G3.

- ◆ Have the web plates designed and manufactured or procure web plates to fit your carrier.
- ◆ Ensure that the web plates are welded to the base plate side marked "TOP".

The adapter plate must not strike in any position during operation of the hydraulic attachment.

Atlas Copco Construction Tools does not design, manufacture or sell web plates for adapter plates.

## Installing the adapter plate

### NOTICE Adapter plate can come loose

The adapter plate can come loose if the fastening screws are not designed for local high loads.

- ▶ Only use the Allen screws of strength category 8.8 and the pairs of lock washers included in the delivery to attach the adapter plate or the base plate.
- ◆ Place the hydraulic breaker on timber support blocks within the range of the carrier. The breaker box service opening must be facing upwards.
- ◆ Remove the transport safety device which keeps the elastic pad (C) and the percussion unit in the breaker box.
- ◆ Apply Anti-Seize to the Allen screw threads (A) before inserting them.

The contact faces of the screw head and the lock washers (B) must not be lubricated.

### ▲ WARNING Hands and fingers being cut off or hurt

Bores and surfaces can act like a pair of scissors and cut off or hurt parts of your body.

- ▶ Never use your fingers to check bores or fitting surfaces.
- ◆ Align the adapter plate (D) to the hydraulic breaker as shown.

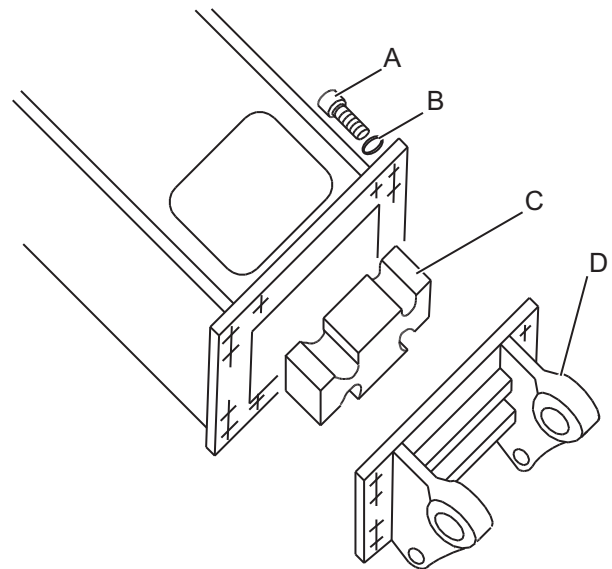

- ◆ Fit a pair of lock washers (B) onto every screw.
- ◆ Tighten the Allen screws (A) with an Allen key.
- ◆ Tighten the Allen screws (A) with the required tightening torque.

Type	Key size	Tightening torque
HB 5800 / HB 5800 DP	27	2300 Nm
HB 7000 / HB 7000 DP	27	2300 Nm
HB 10000 / HB 10000 DP	27	2300 Nm

## Attaching the hydraulic attachment to the carrier

### Mechanical mounting aspects

You need an assistant to attach the hydraulic attachment to the carrier.

- ◆ Agree on hand signals with your assistant, to enable him to help you placing the carrier in the proper position to attach the hydraulic attachment.
- ◆ Lower the stick of the carrier into the holder provided on the adapter plate.

#### ▲ WARNING Injury by impacts

A sudden movement of the carrier may cause your assistant to be hit and injured by the boom or the hydraulic attachment.

- ▶ Only move the boom very slowly and in a controlled manner while an assistant is within the danger zone.
- ▶ Always keep sight of your assistant.

#### ▲ WARNING Hands and fingers being cut off or hurt

Bores and surfaces can act like a pair of scissors and cut off or hurt parts of your body.

- ▶ Never use your fingers to check bores or fitting surfaces.

- ◆ Let your assistant instruct you until the bores in the adapter plate (B) and in the stick (A) are properly aligned.
- ◆ Install the stick bolt (C) and lock it.

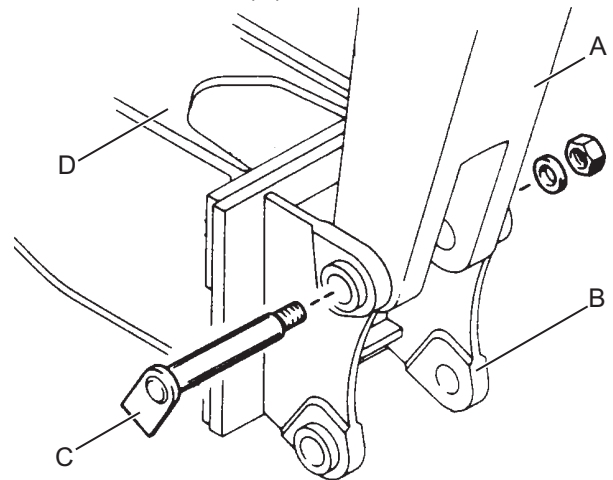

- ◆ Lift the hydraulic attachment (D).

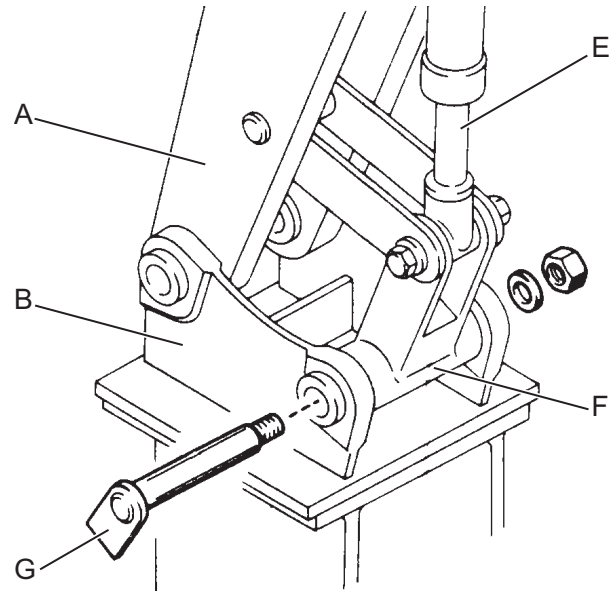

- ◆ Extend the bucket cylinder (E) until the bore in the linkage (F) links up with the bore in the adapter plate (B).
- ◆ Install the linkage bolt (G) and lock it.
- ◆ Carefully move the bucket cylinder (E) into both end positions.

The adapter plate must not be stopped by mechanical stops in either position. Consult the Atlas Copco Customer Center/Dealer in your area if the adapter plate is stopped by a mechanical stop.



## Making the hydraulic connections

### NOTICE Faulty hydraulic installation

The carrier must have a suitable hydraulic installation to operate the hydraulic attachment. Improperly installed lines and incorrect rated sizes may cause the oil to heat up and the hydraulic attachment to be damaged.

- ▶ Only use hydraulic lines of the rated sizes as instructed (see chapter *Technical Specifications*).
- ▶ Check the rated size of the hydraulic lines on existing hydraulic installations! Pressure and tank lines for the hydraulic oil must have a sufficient inside diameter and wall thickness.
- ▶ Lay all hydraulic hoses so that they are torsion-free.

- ◆ Switch off the carrier.
- ◆ Depressurise the hydraulic system according to the manufacturer's safety and operating instructions for the carrier.
- ◆ If no quick couplings are used, close all shut-off valves in the installation at the boom.

**NOTICE** Total damage to the hydraulic attachment  
Polluted hydraulic lines and connections may enable sand, fragments of material and dirt to penetrate the hydraulic attachment and damage it completely.

- ▶ Clean the hydraulic lines and connections before connecting the hydraulic hoses. Lay all hydraulic hoses so that they are torsion-free.
- ◆ Install the pressure and tank hoses.
- ◆ Connect the pressure and tank hoses.

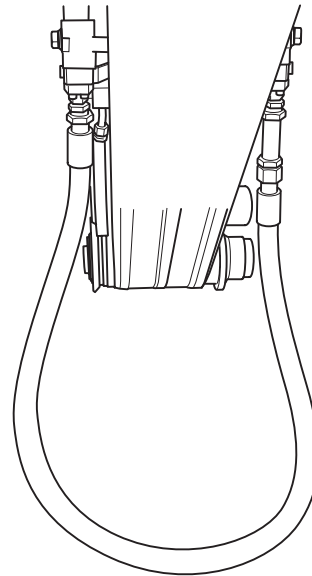

- ◆ If no quick couplings are used, open the shut-off valves in the installation at the boom.
- ◆ Switch on the carrier.
- ◆ Let the hydraulic oil run through the carrier oil filter for approx. three minutes to make sure that the hoses are clean.
- ◆ Switch off the carrier.
- ◆ Depressurise the hydraulic system according to the manufacturer's safety and operating instructions for the carrier.
- ◆ If no quick couplings are used, close all shut-off valves in the installation at the boom.
- ◆ Disconnect the pressure and tank hoses.

### ▲ WARNING Components bursting

Components of the swivel joint may burst. Metal parts may become projectiles and cause serious injuries and damage property.

- ▶ Always check the swivel joint covers are fitted properly when attaching the hydraulic breaker to the carrier.
- ▶ Tighten loosen screw connections (see chapter *Bolt connections / Tightening torques*).
- ▶ Immediately replace a defective swivel joint cover.
- ◆ Remove the caps from the ports »P« and »T« and save them for future use.

The pressure port »P« has been marked with red paint as an extra reference.

- ◆ Check that the ports and connections on the hydraulic breaker and/or on the hydraulic hoses are not damaged.
- ◆ Replace any damaged connections.
- ◆ Connect the pressure hose to port »P«, making sure it is torsion-free.
- ◆ Connect the tank hose to port »T«, making sure it is torsion-free.

**▲ WARNING Hydraulic hose flailing about**

Pressurised hydraulic hoses will flail about when bolted connections have come loose or have been loosened. A hydraulic hose flailing about may cause serious injuries.

- ▶ Tighten the hydraulic hose connection nuts with the required tightening torque.

Tightening torque (see chapter *Bolt connections / Tightening torques*)

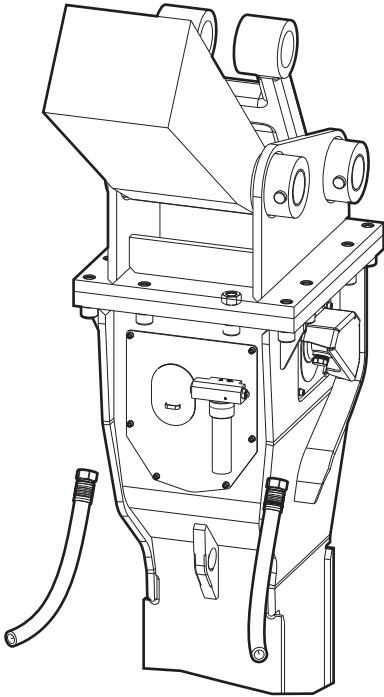

## Removing the hydraulic attachment from the carrier

- ◆ Place the hydraulic attachment on timber support blocks.

### Dismantling the hydraulic connections

#### ▲ WARNING Unexpected movement

Sudden movements of the carrier may cause serious injury.

- ▶ Secure the carrier such that it cannot move unexpectedly.
- ▶ Observe the carrier manufacturer's instructions.

#### ▲ WARNING Hydraulic hose flailing about

Pressurised hydraulic hoses will flail about when bolted connections have come loose or have been loosened. A hydraulic hose flailing about may cause serious injuries.

- ▶ Depressurise the hydraulic system before disconnecting a hydraulic hose (see chapter *Depressurising the hydraulic system*).

#### ▲ WARNING Hot parts

The breaker body, the working tool, hoses, pipes and fittings become very hot during operation. Touching them may lead to burns.

- ▶ Never touch hot parts.
- ▶ If you have to carry out activities where you have to touch the parts, wait for them to cool down first.

- ◆ Close all shut-off valves in the installation at the boom if no quick couplings are used.
- ◆ Disconnect the hose lines to and from the hydraulic attachment at the boom side.
- ◆ Close off all open hose ends.

### Mechanical disassembly

- ◆ You need an assistant to remove the hydraulic attachment.
- ◆ Agree on hand signals with your assistant, to enable him to help you move the boom.

#### ▲ WARNING Injury by impacts

A sudden movement of the carrier may cause your assistant to be hit and injured by the boom or the hydraulic attachment.

- ▶ Only move the boom very slowly and in a controlled manner while an assistant is within the danger zone.
- ▶ Always keep sight of your assistant.

#### ▲ WARNING Metal chips shooting off

When hammering out bolts, chips may shoot off and cause serious eye injuries.

- ▶ Wear safety glasses when hammering out the bolts.
- ◆ Remove the bolt locks from the stick and linkage bolts.
- ◆ Drive out the linkage bolt with a steel arbor and a hammer.
- ◆ Switch on the carrier.
- ◆ Retract the bucket cylinder.
- ◆ Drive out the stick bolt with a steel arbor and a hammer.
- ◆ Move the carrier stick out of the adapter plate.

## Removing the adapter plate

- ◆ Loosen the fastening screws of the adapter plate.
- ◆ Lift the adapter plate with a suitable lifting equipment and put it down on timber support blocks.
- ◆ Lock the elastic pad with the transport safety device.
- ◆ Save the fastening screws and the pairs of lock washers for future use.

## DustProtector

- ◆ Place the hydraulic breaker on timber support blocks.

### ▲ WARNING Unexpected movement

Sudden movements of the carrier may cause serious injury.

- ▶ Secure the carrier such that it cannot move unexpectedly.
- ▶ Observe the carrier manufacturer's instructions.

### ▲ WARNING Metal chips shooting off

When hammering out bolts, chips may shoot off and cause serious eye injuries.

- ▶ Wear safety glasses when hammering out the bolts.

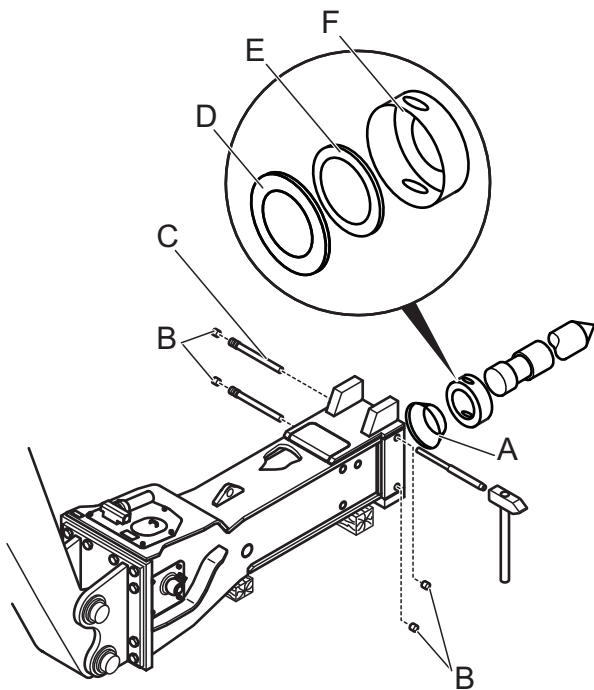

Push the sealing lip of the wiper inwards with your thumb. This pushes the wiper out of the wiper sleeve ring groove.

### Installation

- ◆ Before installing the DustProtector, install the working tool (see chapter *Working tool/Installation*).
- ◆ Manually push the wiper (A) over the working tool and let it click into place in the wiper sleeve ring groove.
- ◆ Use a tool (hammer handle) to push on the wiper (A) at several points.
- ◆ Use your thumbs to push the wiper into place along its circumference.
- ◆ Apply chisel paste to the guide ring (F), floating ring (E) and counter ring (D).
- ◆ Install the floating ring (E) and counter ring (D) in the guide ring (F).
- ◆ Push the rings over the working tool and install them in the lower part of the breaker box.
- ◆ Turn the guide ring (F) so that the apertures in the breaker box and the guide ring are lined up.
- ◆ Drive the lock bolts (C) into place using a break pin punch and a hammer.
- ◆ Seal the apertures in the breaker box with the plugs (B).

### Removal

- ◆ Remove the working tool (see chapter *Working tool/Removal*) before removing the DustProtector.
- ◆ Remove the plugs (B) from the breaker box.
- ◆ Drive out the lock bolts (C) of the DustProtector using a break pin punch and a hammer.
- ◆ Remove the guide ring (F), floating ring (E) and counter ring (D) of the DustProtector system.
- ◆ Remove the wiper (A).

To make the wiper (A) easier to remove:

## Working tool

### ▲ WARNING Unexpected movement

Sudden movements of the carrier may cause serious injury.

- ▶ Secure the carrier such that it cannot move unexpectedly.
- ▶ Observe the carrier manufacturer's instructions.

### ▲ WARNING Metal chips shooting off

When hammering out bolts, chips may shoot off and cause serious eye injuries.

- ▶ Wear safety glasses when hammering out the bolts.

### ▲ WARNING Heavy working tool

The working tool is heavy; if it falls it may cause serious injury. Lifting the working tool without suitable lifting equipment may lead to physical injury.

- ▶ Lift the working tool with lifting equipment designed for the weight of the working tool.

### ▲ WARNING Hands and fingers being cut off or hurt

Bores and surfaces can act like a pair of scissors and cut off or hurt parts of your body.

- ▶ Never use your fingers to check bores or fitting surfaces.
- ▶ Do not reach into the aperture in the lower breaker part or between the working tool and the lower breaker part.

## Selecting the right working tool

The standard available working tools are shown. The different cutter geometries may influence the production result, depending on the actual use. Please consult the following table for recommended uses.

Conical moil point

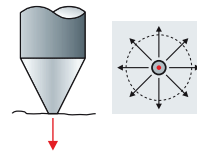

Suitable for universal use  
Very good penetration  
Even splitting effect distribution  
No torsion effect

Pyramidal moil point

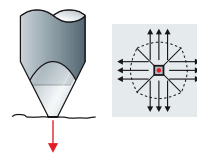

Suitable for universal use  
Very good penetration  
Even splitting effect distribution  
Slight torsion effect

Chisel and spade

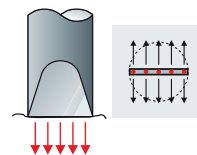

Mining, demolition work, ground work, foundations  
Very good splitting effect distribution  
Very good penetration  
Torsion effect

Blunt tool

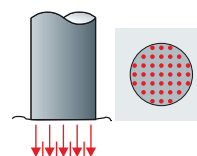

Mining, block holing, demolition work  
Very good energy transfer  
Optimum in-cutting effect  
No torsion effect

**Installation**

- ◆ Place the hydraulic breaker on timber support blocks.

**NOTICE** The working tool may break  
There is an increased risk of the working tool breaking if it has not been stored in frostfree conditions.

- ▶ Store the working tool in a frostfree environment for one day before installing it.  
or
- ▶ Heat up the working tool for several hours, e.g. with a heating blanket, until it has warmed up thoroughly.

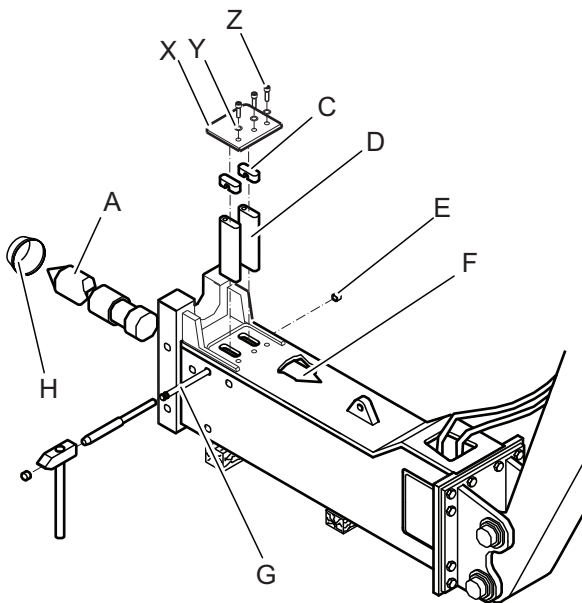

**Wiper installed**  
(only hydraulic breakers with DustProtector):

When installing the working tool for the first time after it has been delivered, you first have to remove the wiper (H) from the DustProtector.

- ◆ Remove the wiper (H) from the DustProtector (see chapter *DustProtector/Removal*).

**NOTICE** Damage to the wiper

If the wiper is not removed it will bend back when installing the working tool. The wiper can then no longer be used.

- ▶ Remove the wiper before installing the working tool.

**Retainer bar installed:**

When installing the working tool for the first time after it has been delivered, you must remove the protective cap and the retainer bars.

- ◆ Remove the protective cap from the aperture for the working tool.
- ◆ Store the protective cap for future use.
- ◆ Remove the screws (Z), washers (Y), plate (X), and plugs (E).
- ◆ Use a break pin punch and a hammer to drive the bolt (G) for the retainer bars (D) out of the lower breaker part (F) from the side.
- ◆ Remove the two plugs (C) from the slotted holes for the retainer bars (D).
- ◆ Screw one screw (M 12) into the bore on the front side of the retainer bars.
- ◆ Pull out the retainer bars by the screw.

**Retainer bar and wiper removed:**

If the retainer bars and the wiper (only on hydraulic breakers with DustProtector) have been removed, proceed as follows:

- ◆ Clean the insertion area of the working tool (A).
- ◆ Grease the insertion area of the working tool (A) with chisel paste.
- ◆ Grease both retainer bars (D) with chisel paste.
- ◆ Install the working tool (A).
- ◆ Put the retainer bars (D) in place.
- ◆ Turn the working tool (A) until the retainer bars (D) slide into place in the slotted holes of the lower breaker part (F).
- ◆ Remove the screw from the retainer bars (D).
- ◆ Install the sealing plugs (C).
- ◆ Drive the bolt (G) into place using a break pin punch and a hammer.
- ◆ Install the plate (X), washers (Y), screws (Z), and the plugs (E).
- ◆ If the hydraulic breaker is a DustProtector type, install the wiper (H) (see chapter *DustProtector/Installing*).

## Removal

- ◆ Place the hydraulic breaker on timber support blocks.

### ▲ WARNING The working tool suddenly comes loose

A clamped working tool is still under the pressure of the piston accumulator. When the working tool is loosened, it will partly jump out of the hydraulic breaker; this may lead to serious injury.

- ▶ Never position yourself directly in front of the installed working tool.

### ▲ WARNING Hot working tool

The tip of the working tool gets very hot during operation. Touching it may lead to burns.

- ▶ Never touch the hot working tool.
- ▶ If you have to carry out any activities, wait for the working tool to cool down first.

- ◆ Remove the screws (Z), washers (Y), plate (X), and plugs (H).

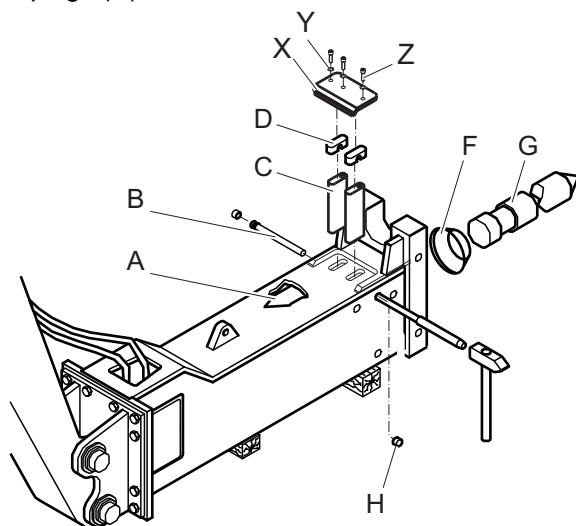

- ◆ Use a break pin punch and a hammer to drive the bolt (B) for the retainer bars (C) out of the lower breaker part (A) from the side.
- ◆ Remove the two plugs (D) from the slotted holes for the retainer bars.
- ◆ Screw one screw (M 12) into the bore on the front side of the retainer bars.
- ◆ Pull out the retainer bars by the screw.
- ◆ Pull the working tool (G) out of the lower breaker part.
- ◆ If the hydraulic breaker is a DustProtector type, remove the wiper (F) (see chapter *DustProtector/Removal*).

## OPERATION

### ▲ WARNING Components bursting

Components of the swivel joint may burst. Metal parts may become projectiles and cause serious injuries and damage property.

- ▶ Never operate the hydraulic breaker without attached swivel joint covers.

### ▲ WARNING Hot hydraulic oil squirting out

The hydraulic system is under high pressure. If hydraulic connections come loose, hydraulic oil will squirt out under high pressure. Hydraulic oil squirting out can lead to serious injury.

- ▶ Immediately switch off the hydraulic attachment and the carrier if you detect any leaks in the hydraulic circuits.
- ▶ Depressurise the hydraulic system (see chapter *Depressurising the hydraulic system*).
- ▶ Repair any leaks before operating the hydraulic attachment again.

### ▲ WARNING Hot parts

The breaker body, the working tool, hoses, pipes and fittings become very hot during operation. Touching them may lead to burns.

- ▶ Never touch hot parts.
- ▶ If you have to carry out activities where you have to touch the parts, wait for them to cool down first.

**NOTICE** Environmental damage due to hydraulic oil

Hydraulic oil is environmentally harmful and must not penetrate the ground or enter the water table or water supplies.

- ▶ Collect any hydraulic oil which escapes.
- ▶ Dispose of it in accordance with the applicable environmental regulations.

**NOTICE** Hydraulic oil too hot

The temperature of the hydraulic oil must not exceed 80 °C. Higher temperatures will damage the seals of the hydraulic breaker and the diaphragm of the HP-accumulator.

- ▶ The temperature of the hydraulic oil must be monitored.
- ▶ Shut off the carrier and the hydraulic breaker if you measure an increased temperature in the tank.
- ▶ Check the hydraulic installation and the pressure relief valve.

**NOTICE** Damage due to idling strokes

If the percussion piston carries out a hammer action without hitting the working tool, it is carrying out an idling stroke. If this happens it will lead to hydraulic peak pressures which may damage the seals of the hydraulic breaker and the carrier.

- ▶ Do not allow the percussion piston to carry out idling strokes for a prolonged period of time.

## Preparations before starting

### ▲ WARNING Falling carrier

A carrier falling or tipping over due to the surface not being level may cause serious injury and material damage.

- ▶ Always observe great care when moving the carrier.
- ▶ Do not use the hydraulic attachment until the carrier is positioned stably.

### ▲ WARNING Fragments flying around

Fragments of material which come loose while operating the hydraulic attachment may be flung away and can cause serious injury if people are hit by them. Small objects falling from a great height can also cause serious damage.

During hydraulic attachment operation the danger zone is considerably greater than during the excavation operation due to fragments of stone and pieces of steel flying around, and for this reason the danger zone must, depending on the type of material to be worked on, be enlarged correspondingly, or secured in a suitable manner through corresponding measures.

- ▶ Secure the danger zone.
- ▶ Stop the hydraulic attachment immediately if anyone enters the danger zone.
- ▶ Close the windscreen and the side windows of the driver's cab.

The preparations required prior to starting the hydraulic attachment depend on the ambient temperature:

- Ambient temperature below 0 °C (see chapter *Low ambient temperature*).
- Ambient temperature above 30 °C (see chapter *High ambient temperature*).

The oil temperature in the hydraulic attachment must be between 0 °C and +80 °C when operating the breaker.

The full capacity of the hydraulic attachment can be achieved when the oil temperature is approx. 60 °C.



- ◆ Make sure that there are no people in the danger zone.
- ◆ Start the carrier as instructed by the carrier manufacturer.
- ◆ Let the carrier heat up until the operating temperature prescribed by the carrier manufacturer has been reached.
- ◆ Put the carrier in its working position.
- ◆ Put the working tool on the material to be broken.

## Switching the hydraulic breaker on and off

After properly attaching the hydraulic attachment to the carrier, the hydraulic attachment can be operated using the carrier's hydraulic system. All functions for normal carrier operation remain intact.

The hydraulic attachment is switched on and off using electrical and hydraulic signals.

If you have any questions about electric/hydraulic commands, consult the carrier manufacturer and/or the Atlas Copco Customer Center/Dealer in your area.

- ◆ Switch the hydraulic attachment on and off, as described in the carrier's operating instructions.
- ◆ When leaving the driver's cab, set the safety switch/lever for the electrical/hydraulic attachment installation to the „OFF“ position.

Carry out the above actions to prevent any unintended start-up of the hydraulic attachment.

## Functional test

Always carry out a functional test before putting the hydraulic attachment into use to check that all hydraulic lines and connections are tight and that the hydraulic attachment works without any problems.

- ◆ Prepare the hydraulic attachment so that you can start using it.
- ◆ Carry out a couple of test impacts on the material to be broken.
- ◆ Check the hydraulic lines and make sure that the hydraulic attachment works without any problems.
- ◆ Immediately switch off the hydraulic attachment if oil escapes from the hydraulic lines or if other defects in functioning occur.
- ◆ Depressurise the hydraulic system (see chapter *Depressurising the hydraulic system*).

- ◆ Only use the hydraulic attachment again after having repaired all leaks and operating defects.

## Correct operation

### Working angle

- ◆ Always position the tool so that it hits the material to be broken at a right angle.

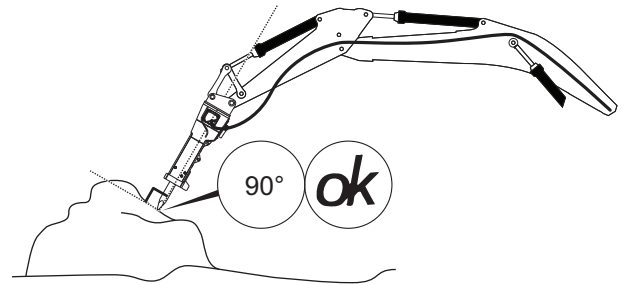

If you do not do this, the hydraulic breaker will wear faster and damage will occur after a while.

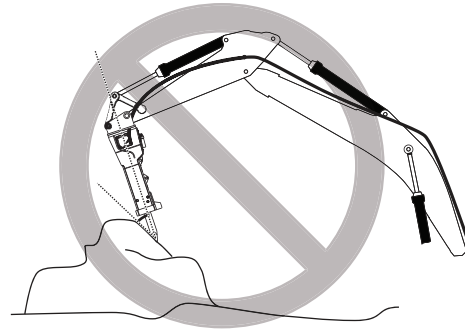

- ◆ Slightly swing the hydraulic breaker to and fro when carrying out the hammer impacts, but never swing it through more than approx. 5°.

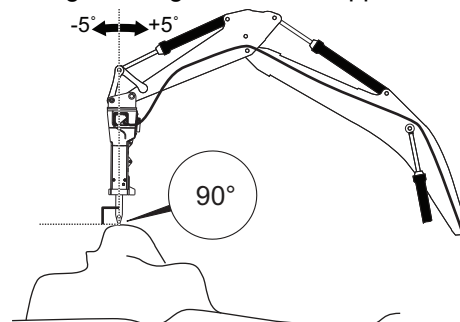

This swing action enables any dust under the tip or the cutter of the working tool to escape. Otherwise a layer of dust is created which would prevent the full percussion energy being transferred to the material to be broken. The tip of the working tool then becomes hot and loses its hardness.

Larger swing angles would lead to bending loads and damage to the working tool and the hydraulic breaker.

### Advance

Select the distance marked with "V" such that the fragment is released within 30 seconds. If this is not the case decrease the advance or apply the tool again to another location.

Excessive advances do not improve the working result. The working tool will then penetrate the material without a satisfactory breaking result. The tip of the working tool then becomes hot and loses its hardness. Work step by step to achieve the optimum work result.

- ◆ Start near the edge of the material to be broken and work your way back to its centre.

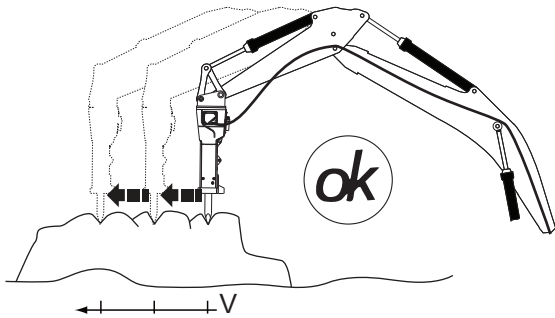

### Impact time

- ◆ Never apply the hydraulic breaker to the same point for more than 30 seconds.

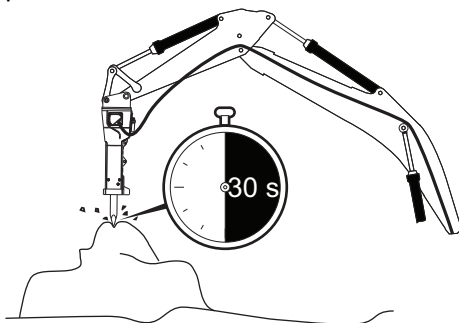

- ◆ If the material fails to break, apply the tool to a new location.

### High ambient temperature

- ◆ Only use hydraulic oils of sufficient viscosity.

In summer and in tropical climates, the minimum requirement is a hydraulic oil of type HLP 68.

### Low ambient temperature

#### Ambient temperature below 0 °C:

**NOTICE** The working tool may break

There is an increased risk of the working tool breaking if it has not been stored in frostfree conditions.

- ▶ Store the working tool in a frostfree environment for one day before installing it.  
or
- ▶ Heat up the working tool for several hours, e.g. with a heating blanket, until it has warmed up thoroughly.

#### Additional instructions when working at an ambient temperature of below -20 °C:

You must heat up the hydraulic attachment and the carrier when working at ambient temperatures of below -20 °C.

Preferably park the carrier and the hydraulic attachment in a heated, sheltered space while not in use.

**NOTICE** Hydraulic oil too cold

Operating the hydraulic breaker while the hydraulic oil is still cold will damage the seals of the hydraulic breaker and the diaphragm in the HP-accumulator.

- ▶ Do not operate the hydraulic breaker until the temperature of the hydraulic oil is at least 0 °C.
- ◆ Start the carrier as instructed by the carrier manufacturer.
- ◆ Let the carrier heat up until the operating temperature prescribed by the carrier manufacturer has been reached.

**NOTICE** Damage to hydraulic parts

If a hydraulic breaker which has not reached operating temperature is operated with hot hydraulic oil this will lead to tensions and the hydraulic breaker will stop working.

- ▶ Do not fill the hydraulic system with hot hydraulic oil.

The temperature of the hydraulic oil of the carrier must be at least 0 °C.

- ◆ Start the hydraulic attachment when the temperature has risen to 0 °C.
- ◆ During operations, leave the carrier engine and pumps running even during breaks.

## Prohibited operation

### Lifting/Transporting

#### ▲ WARNING Falling load

The lifted object can fall and cause serious injuries or death.

- ▶ Never lift or transport loads with the hydraulic attachment.

The hydraulic attachment was not constructed to lift or transport loads. The hydraulic attachment will be damaged by such use.

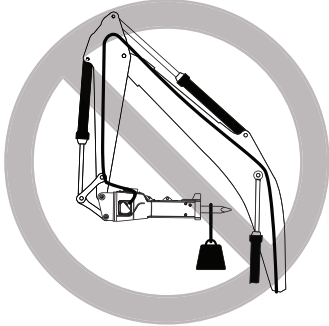

### Impacting

- ◆ Do not use the hydraulic breaker as a sledge hammer to demolish the material.

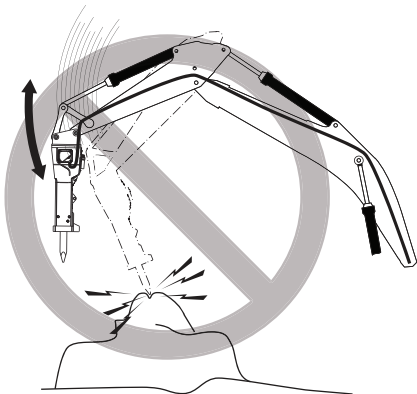

This will damage the hydraulic breaker, the working tool and the carrier.

### Moving objects

- ◆ Never use the hydraulic attachment to move debris.

This would damage the hydraulic attachment.

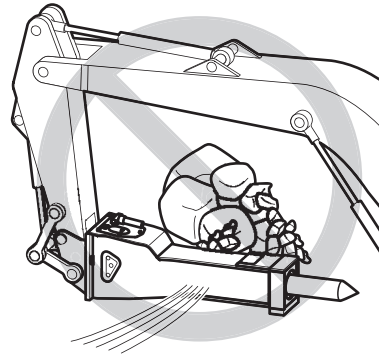

### Levering

- ◆ Never use the working tool for crowbar-type applications.

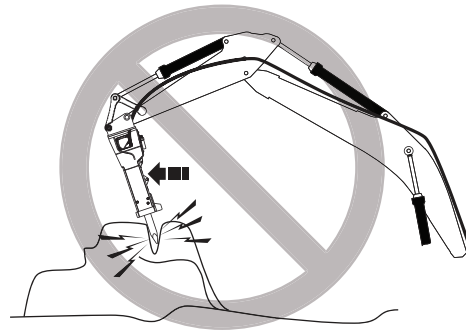

This might cause the working tool to break. Listen to the sound of the hydraulic breaker – it changes when stresses occur between the working tool and the wear bush.

### Blank firing of the working tool

The working tool "blank fires" if the percussion energy is transferred to the retainer bars instead of to the material to be broken.

This happens when the working tool breaks through the material or slips off it, e.g.: when working on thin concrete slabs or layers of loose rocks.

Blank firing of the working tool subjects the hydraulic breaker and the carrier to increased loads.

Blank firing of the working tool generates a typical metallic sound.

- ◆ Try to avoid blank firing of the working tool by:
  - observing the material to be broken to identify whether there is any risk of the working tool breaking through the material or slipping off it.
  - listening to the sound of the hydraulic breaker. You can hear a metallic twang when the working tool is blank firing.
- ◆ Stop the hydraulic breaker when blank firing occurs.

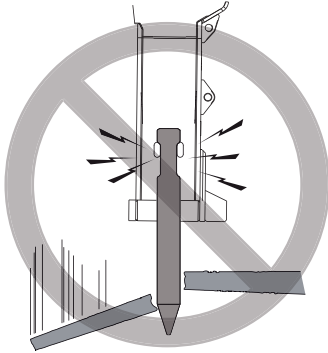

### Cylinder end positions

- ◆ Avoid operating the hydraulic attachment when the carrier stick and bucket cylinder is in one of its end positions.

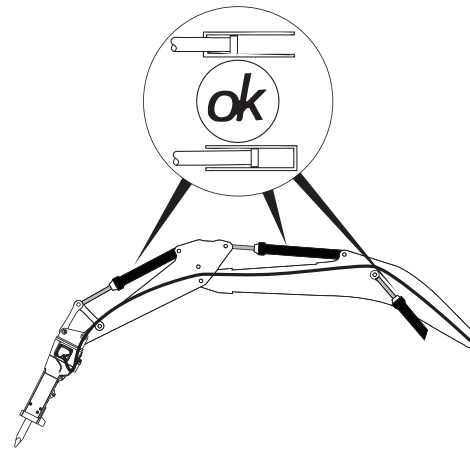
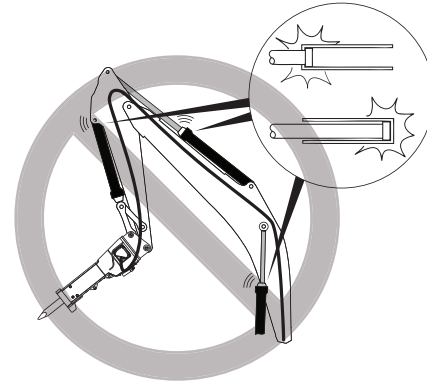

These end positions have damping facilities; the hydraulic cylinder may be damaged by prolonged use while in its end positions.

- ◆ Reposition the carrier so that you do not have to work with the cylinder in its end positions.

## Working with safety equipment

### Underwater applications

Using the hydraulic breaker in and under water is possible if it has been fitted out with special safety equipment.

A special connection kit for underwater use was developed to avoid damage to the hydraulic breaker. It contains all the necessary components including the safety facilities to keep the interior of the lower breaker part free from water by using external compressed air.

Specific documentation, has been drawn up, including operating instructions and a spare parts list, for underwater usage.

- ◆ Before using the hydraulic breaker in or under water, consult the Atlas Copco Customer Center/Dealer in your area.

### Usage in tunnels

Using the hydraulic breaker for tunnelling with overhead operations and horizontal applications or for river bed excavation/slope construction is possible if it has been fitted out with special safety equipment. Dust and stone particles and/or water penetrating the hydraulic breaker can lead to operating failures and can even cause the hydraulic breaker to malfunction completely.

Preventative measures to protect the hydraulic breaker have been collected in separate documentation.

- ◆ Before using the hydraulic breaker for tunnelling work, consult the Atlas Copco Customer Center/Dealer in your area.

### Hot applications

Using the hydraulic breaker in a hot environment is possible if it has been fitted out with special safety equipment.

- ◆ Before using the hydraulic in a hot environment, consult the Atlas Copco Customer Center/Dealer in your area.

## AutoControl System

The AutoControl System is a combination of a pressure-maintaining and reversing valve.

The AutoControl System protects the breaker from damage if blank firing occurs.

The pressure-maintaining valve makes sure that the hydraulic breaker switches correctly in all operating situations. It enables up to 30 % energy to be recovered when working on hard rock.

The reversing valve automatically switches over the hydraulic breaker to a shorter stroke to reduce the single-impact energy.

### AutoControl in daily use

The system works automatically without any manual intervention by the carrier operator and automatically adjusts to the conditions of use.

If the situation requires a high single blow energy, the system produces a full stroke and a high single blow energy.

### AutoControl in special applications

For special applications, e.g. work with very little percussion, the AutoControl System can be blocked mechanically at a high impact rate with a reduced single-impact energy.

For further information, please contact the Atlas Copco Customer Center/Dealer in your area.

## StartSelect System AutoStart/AutoStop

The StartSelect System enables you set the start and switch-off behaviour of the hydraulic breaker to the relevant conditions.

The hydraulic breaker is factory-set to the "AutoStart" setting (= easy start), i.e. the breaker starts in its working position after switching on without exerting pressure on the working tool.

This start behaviour enables greater productivity and easier handling when working on unstable surfaces, e.g.:

- block holing in broken ground or debris
- working in horizontal and/or overhead positions
- reducing light concrete structures

You can integrate the StartSelect valve the other way around to quickly adjust the hydraulic breaker to the "AutoStop" (= automatic switch-off) integration setting.

The hydraulic breaker is switched on while exerting pressure on the working tool in the "AutoStop" (= automatic switch-off) setting. However it will switch off automatically during operation when the percussion piston no longer hits the working tool. Idling strokes are avoided this way.

This setting is an advantage when using the breaker on a stable surface:

- trenching
- slope construction in quarry operations
- digging foundations in rocks
- reducing large concrete structures

### Switching between AutoStart/AutoStop

- ◆ Place the hydraulic breaker on timber support blocks.

#### ▲ WARNING Unexpected movement

Sudden movements of the carrier may cause serious injury.

- ▶ Secure the carrier such that it cannot move unexpectedly.
- ▶ Observe the carrier manufacturer's instructions.

#### ▲ WARNING Jets of hot hydraulic oil can escape

The hydraulic system is under high pressure. If hydraulic connections come loose or are disconnected, hydraulic oil will squirt out under high pressure. Hydraulic lines may spring a leak or burst. Hydraulic oil squirting out can lead to serious injury.

- ▶ Depressurise the hydraulic system before connecting or disconnecting the hydraulic circuits of the hydraulic attachment (see chapter *Depressurising the hydraulic system*).
- ◆ Close all shut-off valves in the system at the boom if no quick couplings are used.
- ◆ Disconnect the hoses to and from the hydraulic breaker on the boom side.
- ◆ Plug up all open hose ends.

"AutoStop" integration setting  
HB 5800/DP, HB 10000/DP

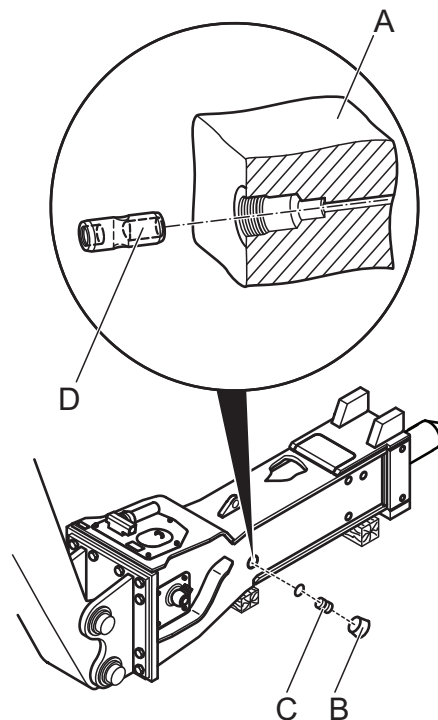

“AutoStop” integration setting  
HB 7000/DP

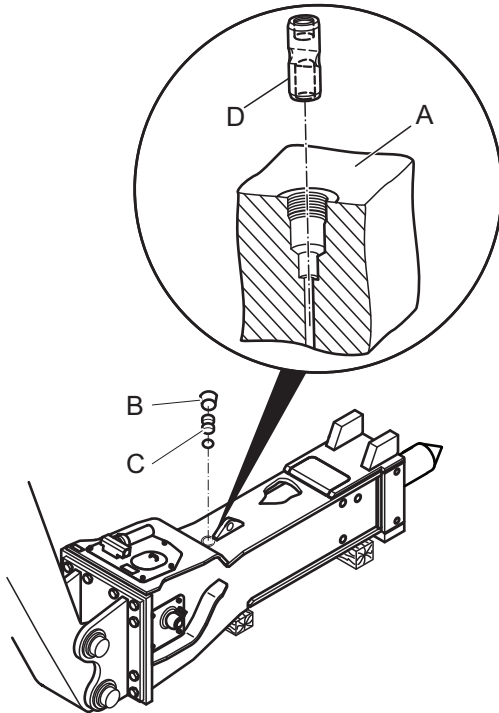

“AutoStart” integration setting  
HB 7000/DP

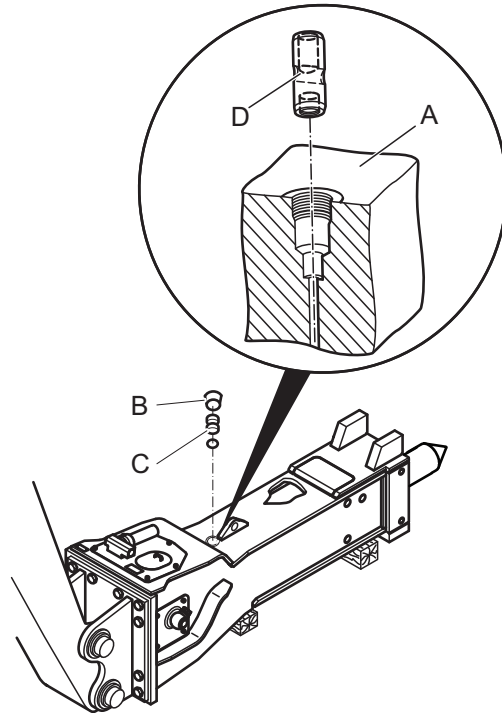

“AutoStart” integration setting  
HB 5800/DP, HB 10000/DP

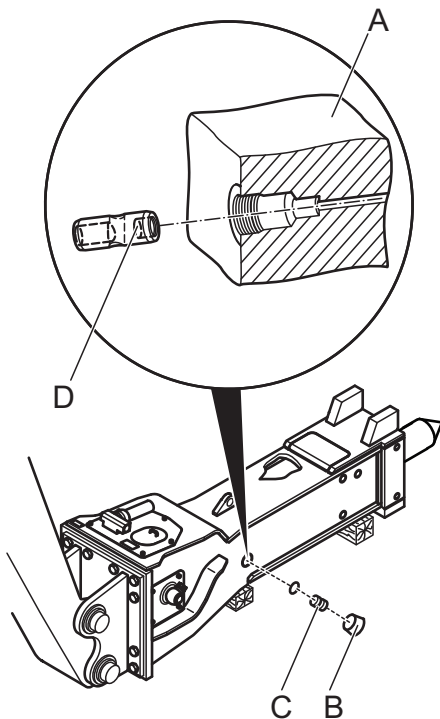

- ◆ Remove the plug (B) from the breaker box.
- ◆ Remove the plug (C). It is located in the cylinder behind plug (B).
- ◆ Screw a screw (M 10) into the valve piston (D).
- ◆ Pull the valve piston (D) by its screw from the bore in cylinder (A).
- ◆ Remove the screw from the valve piston (D) and install it again the other way around.
- ◆ Screw in the plug (C) and tighten it to the required tightening torque (see chapter *Bolt connections / Tightening torques*).
- ◆ Install the plug (B) in the breaker box.

## PowerAdapt

---

PowerAdapt protects the hydraulic breaker against hydraulic overloads and switches it off if the hydraulic input energy is too high.

An overload occurs when the hydraulic breaker is operated while the delivery rate and the pressure from the carrier are too high. The carrier driver can correct this by reducing the engine speed or setting a lower mode stage on the carrier.

Adjusting the delivery rate:

- ◆ Start the carrier.
- ◆ Set the maximum speed and the highest mode stage.
- ◆ Switch on breaker operation.

If the hydraulic breaker fails to work:

- ◆ Lower the speed or the mode stage and restart the hydraulic breaker.
- ◆ Repeat this until the hydraulic breaker works continuously without failures.

The oil volume can be increased after the heat-up phase.

The advantage of PowerAdapt is that manual adjustment puts the maximum percussion energy at your disposal, without overloading the hydraulic breaker.

Hydraulic adjustment of the carrier to enable working with the hydraulic breaker is still necessary, in spite of using PowerAdapt. PowerAdapt is not a pressure-relief valve.



## MAINTENANCE

The maintenance activities are carried out by the carrier driver.

### ▲ **WARNING Hot hydraulic oil squirting out**

The hydraulic system is under high pressure. If hydraulic connections come loose, hydraulic oil will squirt out under high pressure. Hydraulic oil squirting out can lead to serious injury.

- ▶ Immediately switch off the hydraulic attachment and the carrier if you detect any leaks in the hydraulic circuits.
- ▶ Depressurise the hydraulic system (see chapter *Depressurising the hydraulic system*).
- ▶ Repair any leaks before operating the hydraulic attachment again.

### ▲ **WARNING Hot hydraulic oil squirting out**

The hydraulic system is under high pressure. Hydraulic oil escaping out can lead to serious injury.

- ▶ Immediately switch off the hydraulic attachment and the carrier if you detect any leaks in the hydraulic circuits.
- ▶ Do not inspect for possible leaks with your fingers or other parts of the body, but use a piece of cardboard instead, holding it up to the suspected leakage site.
- ▶ Examine the cardboard for traces of liquid.
- ▶ Depressurise the hydraulic system (see chapter *Depressurising the hydraulic system*).
- ▶ Repair any leaks before operating the hydraulic attachment again.

### ▲ **WARNING Hot parts**

The breaker body, the working tool, hoses, pipes and fittings become very hot during operation. Touching them may lead to burns.

- ▶ Never touch hot parts.
- ▶ If you have to carry out activities where you have to touch the parts, wait for them to cool down first.

### ▲ **WARNING Accidental start**

If the hydraulic attachment is started by accident this may lead to serious injury.

- ▶ Follow the instructions in the Operating Instructions of the carrier to prevent the hydraulic attachment starting by accident.

### ▲ **WARNING Unexpected movement**

Sudden movements of the carrier may cause serious injury.

- ▶ Secure the carrier such that it cannot move unexpectedly.
- ▶ Observe the carrier manufacturer's instructions.

**NOTICE** Environmental damage due to hydraulic oil

Hydraulic oil is environmentally harmful and must not penetrate the ground or enter the water table or water supplies.

- ▶ Collect any hydraulic oil which escapes.
- ▶ Dispose of it in accordance with the applicable environmental regulations.

## Maintenance schedule

during a shift	<p>Monitor the filling level of the grease cartridge of the ContiLube® II lubrication system and immediately replace an empty cartridge.</p> <p>Monitor the lubricant film on the shaft of the working tool.</p> <p>Manual lubrication of the working tool approx. every 2 hours.</p>
daily	<p>Check the hydraulic lines for leaks.</p> <p>Check that the pipe clamps on the carrier are tight.</p> <p>Check the screw connections of the swivel joint covers and tighten as required.</p> <p>Replace damaged swivel joint covers.</p>
during and after the first 50 operating hours	<p>Tighten the screw connections daily during the first 50 operating hours.</p> <p>Replace the oil filter cartridges after the first 50 operating hours.</p> <p>Check the fill pressure of the HP-accumulator during the first operating week.</p>
weekly	<p>Visual check of the tensioning bolts through the service openings placed at the top of the breaker box's rear side.</p> <p>Check the screw connections and tighten as required.</p> <p>Check the pins in the retainer bars.</p> <p>Check that the plugs of the retainer bars are in place and are not damaged.</p> <p>Replace any damaged plugs.</p> <p>Check the adapter plate and the breaker box for cracks.</p> <p>In normal use:</p> <p>Clean and grease the DustProtector system.</p> <p>Check the connecting fittings of the ContiLube® II system for leaks.</p>
monthly	<p>Check the gas pressure in the piston accumulator monthly, and in cases of decreasing power or failure of the hydraulic breaker.</p>
after the first three operating month	<p>Check the fill pressure of the HP-accumulator.</p>
every 500 operating hours	<p>Check the oil filter and replace as required.</p>
when replacing the working tool, and at least every 100 operating hours	<p>Check the working tool for wear.</p> <p>Check the lower and upper wear bush for wear.</p> <p>Check that the piston impact surface is not chipped.</p> <p>Check that the working tool impact surface is not chipped.</p> <p>Check the working tool for burrs.</p> <p>Check the retainer bar for burrs.</p>
annual	<p>Check the fill pressure of the HP-accumulator.</p>
if necessary	<p>Replace bent and damaged pipes.</p> <p>Replace damaged hoses.</p> <p>Check the pressure in the piston accumulator.</p> <p>In case of dusty conditions:</p> <p>Clean and grease the DustProtector system.</p> <p>Check the adapter plate bolts for wear.</p>

## Depressurising the hydraulic system

Even when you have switched off the carrier, a considerable residual pressure can still be present in the hydraulic system.

A residual pressure can still be present in the hydraulic breaker even after you have disconnected the quick-release couplings or closed the shut-off valves.

The hydraulic breaker can only be depressurised using the hydraulic system of the carrier, by allowing hydraulic oil to drain to the tank via the return connection.

If the hydraulic breaker is fitted with a high-pressure accumulator, it can take longer to relieve the pressure in the hydraulic system to the tank, since a larger volume of oil has to be drained away.

Depending on the type of hydraulic breaker, the internal leaks, the oil temperature, the type of hydraulic oil and the design of the hydraulic installation of the carrier, the time required to relieve the pressure can vary.

Depending on the hydraulic system of the carrier you will have to consider using various measures in order to depressurise the hydraulic system.

### Case 1:

If measurement connections are present in the supply pipe to the hydraulic breaker, with which the depressurised state can be checked using a suitable gage. In order to depressurise the hydraulic breaker you must observe the following steps:

1. The hydraulic breaker must be connected to the hydraulic system of the carrier device, i.e. the hydraulic hoses must be connected up and the respective shut-off valves in the supply pipe and in the connection to the tank must be opened.
2. Depressurise the hydraulic system according to the manufacturer's safety and operating instructions for the carrier.
3. Measure the pressure with a suitable gage at a measurement connection in the supply pipe to the hydraulic breaker.
4. If residual pressure is still present, wait until the pressure has been completely relieved.
5. When you have made sure that no more pressure is present in the hydraulic system, you must disconnect the hydraulic connection to the carrier. Close the shut-off valves or disconnect the quick-release couplings, so that no hydraulic oil can flow back from the carrier.

### Case 2:

If no facility for measuring the pressure is present in the supply pipe to the hydraulic breaker and the return pipe is connected to the tank without an intermediate valve connection, you must observe the following steps in order to depressurise the hydraulic breaker:

1. Ensure that the hydraulic oil in the hydraulic breaker and in the carrier has a temperature of at least 0 °C. If necessary, pre-heat it to at least 0 °C.
2. The hydraulic breaker must be connected to the hydraulic system of the carrier, i.e. the hydraulic hoses must be connected up and the respective shut-off valves in the supply pipe and in the connection to the tank must be opened.
3. Depressurise the hydraulic system according to the manufacturer's safety and operating instructions for the carrier.
4. You must wait at least another 30 minutes until the pressure has been relieved through leakages.

Only after this period of time will there be no more residual pressure present in the hydraulic system of the hydraulic breaker.

5. When you have made sure that no more pressure is present in the hydraulic system, you must disconnect the hydraulic connection to the carrier. Close the shut-off valves or disconnect the quick-release couplings, so that no hydraulic oil can flow back from the carrier.

### Case 3:

If no facility for measuring the pressure is present in the supply pipe to the hydraulic breaker and the return pipe is connected to the tank via intermediate valves, which for example close off or pressurise the return pipe, you must observe the following steps in order to depressurise the hydraulic breaker:

1. The hydraulic breaker must be connected to the hydraulic system of the carrier, i.e. the hydraulic hoses must be connected up and the respective shut-off valves in the supply pipe and in the connection to the tank must be opened.
2. Depressurise the hydraulic system according to the safety and operating instructions from the carrier manufacturer, and where appropriate, those of the manufacturer of the hydraulic installation for the attachment.
3. When you have made sure that no more pressure is present in the hydraulic system, you must disconnect the hydraulic connection to the carrier device. Close the shut-off valves or disconnect the quick-release couplings, so that no hydraulic oil can flow back from the carrier.

## Cleaning

**NOTICE** Environmental damage due to polluted water

Hydraulic oil and chisel paste are environmentally harmful and must not penetrate the ground or enter the water table or water supplies.

- ▶ Collect the water used for cleaning if it has been contaminated by hydraulic oil and chisel paste.
- ▶ Dispose of the water in accordance with the applicable regulations to avoid environmental hazards.

### Preparations

#### Hydraulic breaker installed:

- ◆ Place the breaker on the working tool and exert a slight pressure.

This prevents water penetrating the percussion piston.

#### Hydraulic breaker not installed, working tool removed:

- ◆ Plug up all hydraulic ports.
- ◆ Seal the aperture for the working tool with the protective cap.

### Procedure

**NOTICE** Damage to the hydraulic breaker

Water can penetrate the percussion chamber via the percussion chamber ventilation non-return valve. This may cause the percussion piston to rust which may result in damage to the seals and the cylinder.

- ▶ Never direct the pressure cleaner jet onto the percussion chamber non-return valve.
- ◆ Use a pressure cleaner to remove dirt from the hydraulic breaker.

## Lubrication

### Checking the lubricant film

The lubricant film on the shaft of the working tool must be checked during the work shift.

- ◆ Let the hydraulic breaker hang freely from the carrier boom.

When the working tool is hanging from the retainer bars, the lubricant film on the shaft of the working tool becomes visible. There must be an even film of lubricant on the entire shaft.

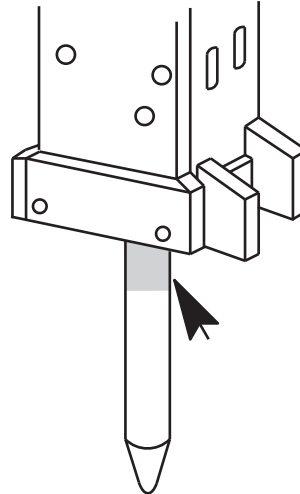

- ◆ Increase the lubricant supply if the film of lubricant comes away or dry spots can be seen:
  - Automatic lubrication: increase the lubricant supply via the metering screw of the ContiLube® II.
  - Manual lubrication: increase the lubrication interval and the number of strokes from the manual grease gun.

**NOTICE** Damage due to excessive lubrication  
Excessive lubrication may damage the hydraulic breaker and the carrier. The impact surface of the working tool must be free of grease.

- ▶ Do not over-lubricate the working tool.

If the ContiLube® II automatic lubrication system has been installed, a lubrication pulse is triggered whenever the hydraulic breaker is switched on.

- ◆ Adjust the lubricant supply to your work method.

### Automatic lubrication

The hydraulic breaker is lubricated automatically by the ContiLube® II.

The ContiLube® II has been installed near the service opening in the upper section of the breaker box.

Instructions on how to operate and maintain the ContiLube® II is described in a separate documentation.

- ◆ If you have questions how to use the ContiLube® II, contact the Atlas Copco Customer Center/dealer in your area.

### Replacing the lubricant cartridge

- ◆ Unscrew and remove the empty lubricant cartridge and the old seal by turning counter clockwise.
- ◆ Remove the cover from the new cartridge. Make sure not to damage the sealing cone (A).
- ◆ Place the seal (B) on the cartridge.

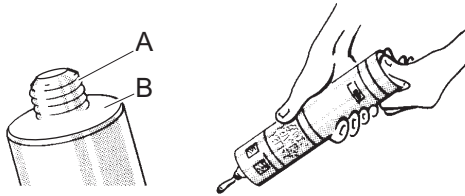

- ◆ Use your thumb to push the cartridge piston down until lubricant escapes from the screw thread.
- ◆ Screw the cartridge until the stop into the guide hole of the grease pump.

The ContiLube® II is ready for use.

### ContiLube® II operation

Please remember the following:

- The ContiLube® II is self-venting, i.e. the system does not require you to vent it.
- The filling level of the transparent cartridge of recyclable PE plastic can always be checked from the cab by looking at the position of the red piston.
- The piston side of the cartridge must never be sealed since no grease supply is possible then.
- You can change the supply volume per stroke by adjusting the metering screw (A), depending on the actual use.
- Tighten the screw clockwise = less grease
- Loosen the screw counter-clockwise = more grease

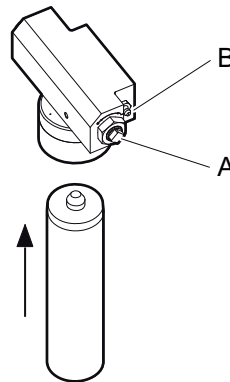

The pump unit must always be sealed to prevent water and dust penetrating it.

- ◆ Use a dust cover or leave the empty cartridge in the pump until a new cartridge is available.
- ◆ Check the tightness of the connections of all hoses for the ContiLube® II operation once a week.

Emergency lubrication is possible via the grease nipple (B) on the rear of the ContiLube® II.

**Manual lubrication**

Manual lubrication is required if the automatic lubrication system fails to work.

- ◆ Place the hydraulic breaker at a right angle on the working tool and exert pressure.
- ◆ Only use chisel paste for lubrication.
- ◆ Put the manual grease gun on the grease nipple of the emergency lubrication system and inject chisel paste.

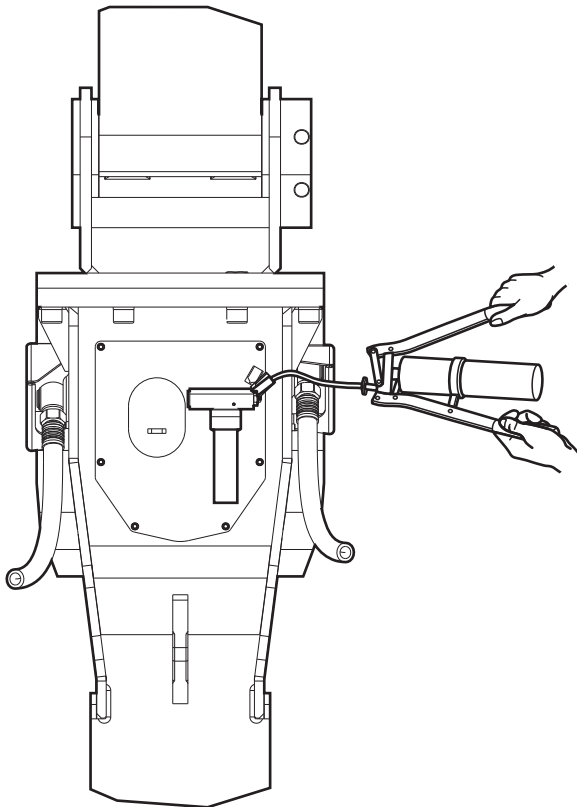

- Lubrication interval: approx. every 2 hours
- Hydraulic breaker without DustProtector: 5 to 15 strokes from the manual grease gun
- Hydraulic breaker with DustProtector: 5 to 10 strokes from the manual grease gun

**Chisel paste filling device**

Atlas Copco Construction Tools offers a device for refilling empty cartridges. This can be mounted on a 15-kg or 45-kg hobbock to fill empty cartridges as required.

500-g chisel paste cartridges  
packed per 12 cartridges:

part number 3363 0912 00 for ContiLube® II  
Manual grease gun for ContiLube® II cartridges:

part number 3363 0345 67

15-kg chisel paste container,  
part number 3362 2639 00

Filling device for use with 15-kg containers:  
part number 3363 0946 69

45-kg chisel paste container,  
part number 3362 2632 75

Filling device for use with 45-kg containers:  
part number 3363 0664 11

For further information, please contact the Atlas Copco Customer Center/Dealer in your area.

## Checking the tensioning bolts

### ▲ WARNING Rupturing washers become projectiles

Washers can rupture and cause serious injuries, if you hit the heads of the tensioning bolts or the washers.

- ▶ Never check the tensioning bolts by acoustic test, but by visual test.

The visual check is only an indication. You can only check doubtless in a repair shop after removing the adapter plate and the elastic pad.

- ◆ Remove the covers of the service openings which are placed at the top of the breaker box's rear side.
- ◆ Check the seat of the paint marks which are placed on the heads of the tensioning bolts and washers.

The paint marks have to be in your visual field. In other cases, the respective tensioning bolt can be loose or broken. In this case act as follows:

- ◆ Dismount the adapter plate and the elastic pad (see chapter *Removing the adapter plate*).
- ◆ Check the tensioning bolt for tight fit.
- ◆ Tighten the loose tensioning bolt with the torque required. (see chapter *Bolt connections/Tightening torques*).
- ◆ Strip the old paint mark.
- ◆ Mark new the tighten tensioning bolt, the washer and the cylinder cover with a colour cast of 10 mm width vertically over all three parts. The paint mark shall be seen in the centre of the service openings.
- ◆ Have broken tensioning bolts immediately replaced.
- ◆ If you have any questions about replacement of broken tensioning bolts, consult the Atlas Copco Customer Center/Dealer in your area.

You can only check the front tensioning bolts, if you dismount the adapter plate and the elastic pad (see chapter *Removing the adapter plate*).

- ◆ Check the tensioning bolts weekly for tight fit.

## Checking the working tool

### ▲ WARNING Hot working tool

The tip of the working tool gets very hot during operation. Touching it may lead to burns.

- ▶ Never touch the hot working tool.
- ▶ If you have to carry out any activities, wait for the working tool to cool down first.

- ◆ Remove the working tool (see the chapter *Dismantling the working tool*).
- ◆ Check the impact surface of the working tool for chips and cracks.
- ◆ Check the impact surface of the working tool for deformation:

A = new working tool

B, C = worn working tool

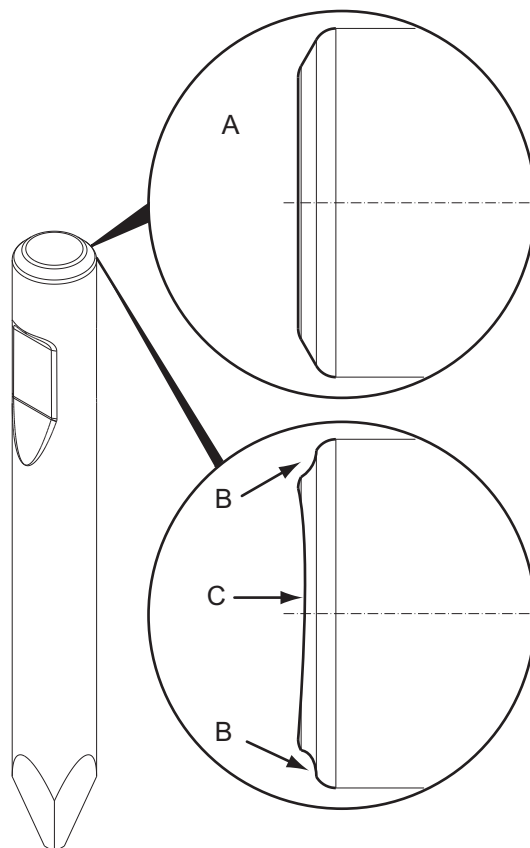

- ◆ Replace the working tool if you detect chips, cracks or deformations (B and C).
- ◆ Check the wear condition of the impact ring if you detect deformations (B). Replace impact ring if necessary.

- ◆ Check the shaft of the working tool for wear whenever replacing it, but at least once every 100 operating hours.

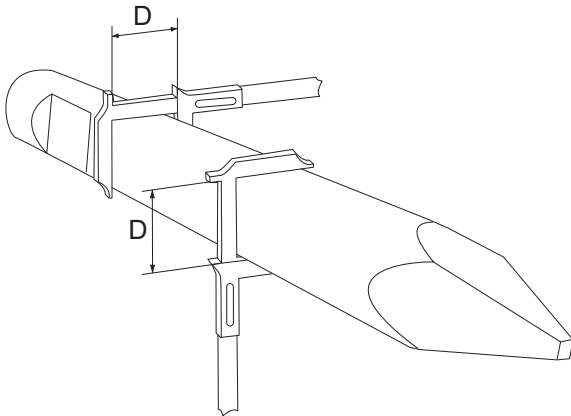

- ◆ Replace the working tool if the shaft has worn to the minimum diameter  $D_{min}$  stated below.

Type	$D_{min}$
HB 5800, HB 5800 DP	195 mm
HB 7000, HB 7000 DP	205 mm
HB 10000, HB 10000 DP	235 mm

## Checking the retainer bars

- ◆ Check both retainer bars whenever replacing working tools.
- ◆ Rework or replace the retainer bars if you find any signs of wear, such as sharp edges, notches or severe erosion.
- ◆ Deburr the retainer bars by careful grinding.
- ◆ Install the retainer bars in their reversed orientation if they cannot be reworked anymore.
- ◆ Replace the retainer bars if both sides cannot be reworked anymore.
- ◆ Check both plugs for the retainer bars. The plugs must not be damaged.

## Checking the percussion piston impact surface

- ◆ Check the percussion piston impact surface whenever replacing the working tool, but at least once every 100 operating hours to make sure it is not chipped and has no visible cracks.
- ◆ Use an electric torch to illuminate the surface of the dismantled working tool.
- ◆ Do not use the hydraulic breaker again if you have found the surface to be chipped or cracked.
- ◆ Consult the Atlas Copco Customer Center/Dealer in your area.

## Checking the wear bushes and impact ring

The wear bushes can be checked after removing the working tool. You can check the diameter using the enclosed test gauge.

The diameter measured must not exceed the maximum permissible diameter  $D_{max}$ .

Type	Size information on test gauge	$D_{max}$
HB 5800, HB 5800 DP	Ø 200	205 mm
HB 7000, HB 7000 DP	Ø 210	215 mm
HB 10000, HB 10000 DP	Ø 240	245 mm

- ◆ Check the inside diameter of the lower and upper wear bush whenever replacing the working tool, but at least once every 100 operating hours.
- ◆ Clean the area around the buffer ring to enable a visual check.

The lower wear bush can be replaced on site. Consult the Atlas Copco Customer Center/Dealer in your area.

- ◆ Remove all remnants of lubricant from the inside of the lower breaker part before installing new parts.



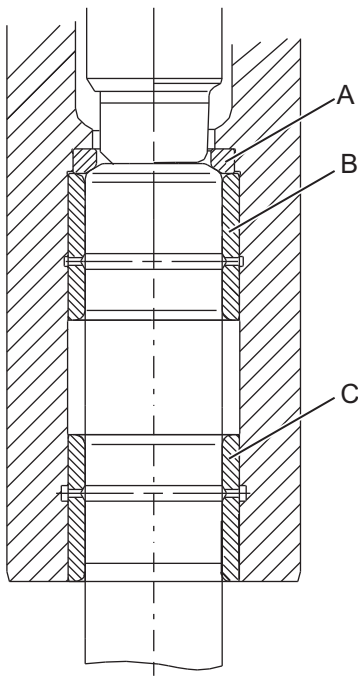

- A. impact ring
- B. upper wear bush
- C. lower wear bush

The upper wear bush and the impact ring must be replaced in a workshop fitted out for this purpose.

- ◆ Replace the lower wear bush when its inside diameter is greater than the maximum permissible diameter.
- ◆ When replacing the lower wear bush check the inside diameter of the upper wear bush using inside callipers (part number 3363 0949 52).
- ◆ Replace the upper wear bush and the impact ring when the inside diameter is greater than the maximum permissible diameter.
- ◆ Replace the buffer ring if you find chips and cracks.

## Checking and cleaning the DustProtector system

An important factor for the DustProtector operation is that the floating ring which moves in a radial direction can follow the movements of the breaker and the working tool.

If dust penetrates it, it may block up the available installation space and interfere with the DustProtector system operation.

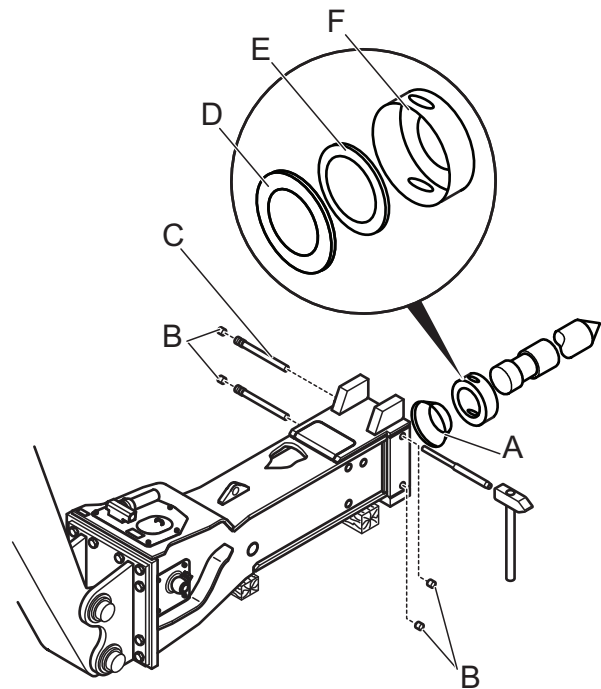

- ◆ Regularly check that the floating ring (E) can move freely.

**NOTICE** Environmental damage due to chisel paste  
Chisel paste is environmentally harmful and must not penetrate the ground or enter the water table or water supplies.

- ▶ Dispose of chisel paste polluted by dust and of cloths with chisel paste in accordance with the applicable regulations to avoid environmental hazards.

Regular cleaning and greasing of the installed parts and their holders safeguards their operation and improves the availability of the hydraulic breaker.

The inspection frequency depends on how much dust is generated:

Normal dust generation:

once a week (assuming 40–50 hours of operation).

- ◆ Check more frequently if the floating ring (E) is stuck.
- ◆ Remove the floating ring (E), counter ring (D) and guide ring (F) (see chapter *DustProtector/Removal*).
- ◆ Clean the space in front of the flexible wiper (A) of all loose dust.
- ◆ Check the wiper (A) for damage.
- ◆ Replace the wiper (A) if it is damaged.
- ◆ Check the inside diameter of the floating ring (E) with a suitable test gauge or with an inside calliper.

Type	Size information on test gauge	D <sub>max</sub>
HB 5800 DP	Ø 200	205 mm
HB 7000 DP	Ø 210	215 mm
HB 10000 DP	Ø 240	245 mm

The diameter measured must not exceed the maximum permissible diameter D<sub>max</sub>.

- ◆ If it has eroded so much that its inside diameter has become too great, replace the floating ring (E).
- ◆ Clean and grease the floating ring (E), counter ring (D) and guide ring (F) and install them again (see chapter *DustProtector/Installation*).

## Piston accumulator

The pressure in the piston accumulator is measured at the filling valve (G). The piston accumulator is also filled through this valve.

HB 5800, HB 5800 DP

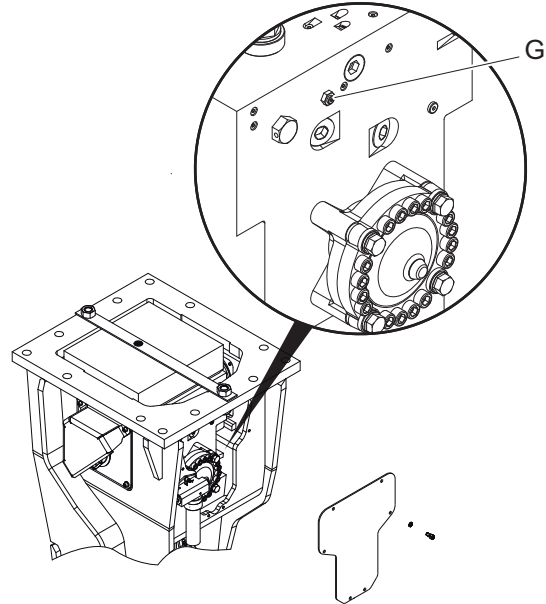

HB 7000, HB 7000 DP

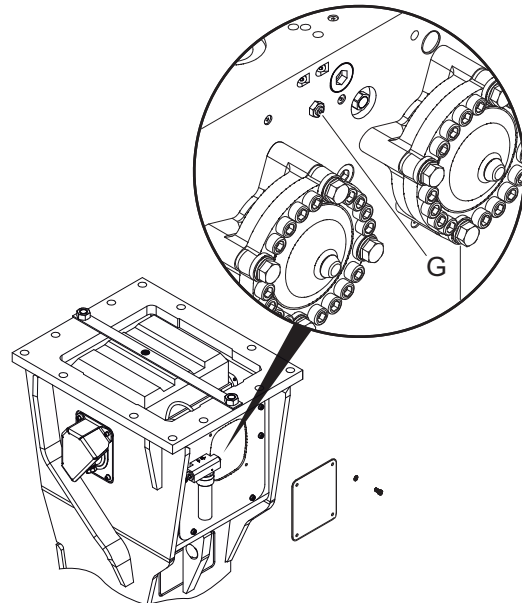

HB 10000, HB 10000 DP

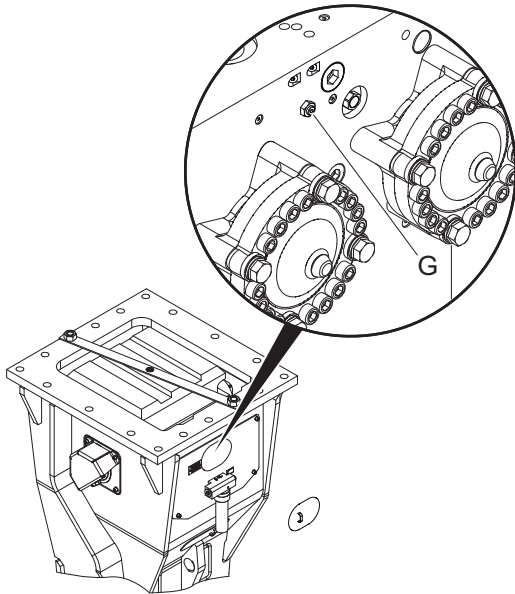

The following accessories can be supplied:

- 1 nitrogen filling device
- 1 test pressure gauge 1/4", 0-25 bar, test category 1.6
- 1 nitrogen bottle
- 1 adapter, country-specific

To enable the following inspection and maintenance activities to be carried out, the equipment referred to above has to be directly available at the location of use at all times.

### Checking the pressure in the piston accumulator

Check the gas pressure in the piston accumulator if the hydraulic breaker does not work. Do not top up the piston accumulator unless the gas pressure is equal to or less than the minimum gas pressure.

Check the pressure in the piston accumulator when the hydraulic breaker is at operating temperature (60-70 °C).

- ◆ Lay down the hydraulic breaker.

Do not apply pressure to the working tool.

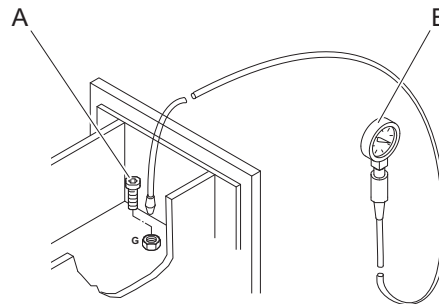

- ◆ Remove the threaded plug (A) from the filling valve »G«.
- ◆ Push the hose end of the test pressure gauge (B) into the filling valve and note the pressure.
- ◆ If the value measured is below the required gas pressure add nitrogen into the piston accumulator.

The required pressure in the piston accumulator is:

**with an operating temperature 60-70 °C and without exerting pressure!**

Type	Minimum gas pressure	Required gas pressure
HB 5800, HB 5800 DP	9.4 bar	12.5 bar
HB 7000, HB 7000 DP	9.0 bar	11.5 bar
HB 10000, HB 10000 DP	9.0 bar	11.1 bar

### Release the pressure from the piston accumulator

- ◆ Release gas from the piston accumulator to depressurise the piston accumulator or if the value measured is above the required gas pressure.

**NOTICE** Damage to the filling valve

Nails, screwdrivers or similar objects can damage the filling valve.

- ▶ Never use nails, a screwdriver or similar objects to release nitrogen gas from the piston accumulator.

- ◆ Push the hose end of the test pressure gauge into the filling valve again.

This will cause gas to escape from the piston accumulator.

- ◆ Repeat this until the required gas pressure has been reached or until the piston accumulator is depressurized.
- ◆ Install the threaded plug (A) in the filling valve (G).

### Filling/topping up the piston accumulator

#### ▲ **WARNING Unexpected movement**

If the working tool has got stuck, it might come loose unexpectedly if the pressure in the piston accumulator is increased. The unexpected impact may lead to serious injury.

- ▶ When filling the piston accumulator make sure that there is nobody within the direct vicinity of the working tool.

If a country-specific adapter (E) is required, it has to be installed between the nitrogen bottle and the pressure relief valve (D).

- ◆ Connect the pressure relief valve (D) to the nitrogen bottle.

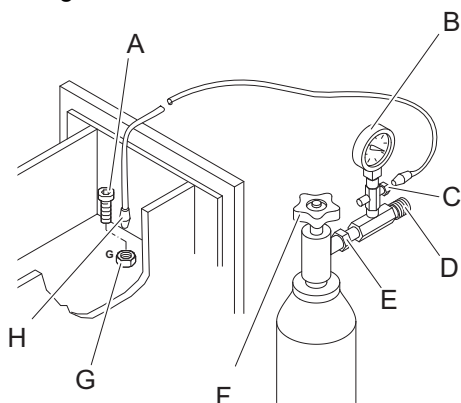

- ◆ Open the valve of the nitrogen bottle (F).
- ◆ Remove the threaded plug (A) from the filling valve (G).
- ◆ Push the free filling hose end (H) into the filling valve (G).
- ◆ Slowly open the pressure relief valve (D) to let the nitrogen flow into the piston accumulator.
- ◆ Read out the pressure increase from the pressure gauge (B).
- ◆ Close the pressure relief valve (D) when the piston accumulator has reached the required pressure +10 %.
- ◆ Pull the filling hose out of the filling valve (G).
- ◆ Check the pressure in the piston accumulator and let gas escape until the required gas pressure has been reached.
- ◆ Install the threaded plug (A) in the filling valve (G) and tighten it to the required tightening torque (see chapter *Bolt connections / Tightening torques*).
- ◆ Close the nitrogen bottle valve (F).

- ◆ Close the pressure relief valve (D).
- ◆ Connect the filling hose end (H) to the minimes connection (C) of the pressure relief valve (D).

## HP-accumulator

Accumulators are pressure containers in the context of the European Pressure Equipment Directive 97/23/EC.

### Checking the expansion bolts

Once a week, check that the HP-accumulator expansion bolts are tight.

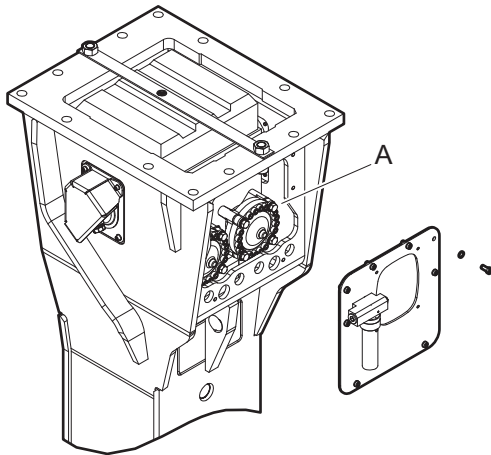

exact location may differ depending on breaker type

- ◆ Check that the expansion bolts (A) are tight.
- ◆ Tighten any loose bolts to the right tightening torques (see chapter *Bolt connections / Tightening torques*).
- ◆ If any of the HP-accumulator expansion bolts are broken, replace all bolts.

If the pressure line »P« starts to flail violently there is a problem with the HP-accumulator operation.

- ◆ Immediately stop the hydraulic breaker.

### ▲ WARNING Component coming loose abruptly

The HP-accumulator is under pressure, even when the hydraulic system has been depressurised. Screw connections and parts of the HP-accumulator might come loose abruptly and cause injuries.

- ▶ Never unscrew the cover or the upper shell from a pressurised HP-accumulator.
- ▶ Have the HP-accumulator checked in accordance with the national / regional safety provisions.

### Checking the gas pressure

After the first installation of the hydraulic breaker, the fill pressure of the HP-accumulator must be checked at least once during the first week. If no loss of gas is found, the second check is to be carried out after three months. If no change in pressure is found at that stage, then testing can be switched to annual.

Further checks, e.g. prior to installation and recurring checks, are to be carried out in accordance with national regulations.

- ◆ Check the gas pressure by using the accumulator filling device.
- ◆ Follow the procedure in the respective operating instructions.

The pre-fill pressure changes with the gas temperature. After filling or releasing nitrogen, it is necessary to wait until the temperature has levelled before checking the gas pressure (20 °C).

- ◆ Replace the HP-accumulator if necessary.

Instructions on how to replace the HP-accumulator is described in a separate documentation.

- ◆ Before replacing the HP-accumulator, consult the Atlas Copco Customer Center/dealer in your area.

## Checking the hydraulic lines

- ◆ Before starting your work shift, always carry out a visual check of all lines (pipes and hoses) from the pump to the hydraulic attachment and from there to the tank.
- ◆ Tighten any loose screw connections or hose clamps.
- ◆ Replace damaged pipes and/or hoses.

## Checking and cleaning the hydraulic oil filter

An oil filter must be integrated in the tank line of the hydraulic system. The maximum mesh width allowed for the oil filter is 50 microns; it must have a magnetic separator.

- ◆ Replace the oil filter cartridges after the first 50 operating hours.
- ◆ Check the oil filter every 500 operating hours and replace as required.

## Checking the adapter plate and the breaker box for cracks and/or wear

---

- ◆ Check the adapter plate and the breaker box for cracks every week.
- ◆ Have rework activities or repairs carried out in time to avoid major damage.
- ◆ The wear rails (A) in the lower section of the breaker box can be replaced as required. Please consult the Atlas Copco Customer Center/dealer in your area.

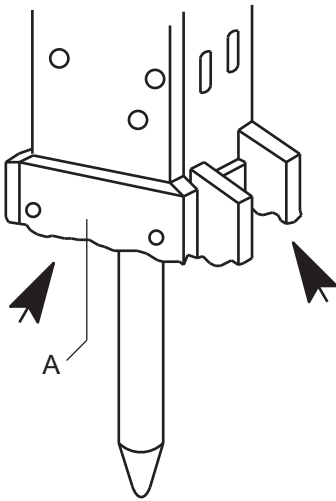

If the wear rails have worn severely, this may cause damage to the basic body of the breaker box.

## Checking the adapter plate bolts for wear

---

- ◆ Carry out this visual check whenever the hydraulic attachment has been removed from the carrier.
- ◆ Check the adapter plate bolts for excessive wear such as cracks, pitting or severe erosion.
- ◆ Rework or replace worn bolts.

## Bolt connections/Tightening torques

The bolt connections of hydraulic breakers are subjected to very high loads.

- ◆ Tighten any loose connections without exceeding the recommended tightening torques.

				HB 5800 HB 5800 DP	HB 7000 HB 7000 DP	HB 10000 HB 10000 DP
Connection point	Pos.	Interval	Type of spanner	Size Torque	Size Torque	Size Torque
Adapter plate* (fastening screws)	A	daily	Allen key		27 mm 2300 Nm	
Tensioning bolts**	B	weekly visual check	Torque wrench/ power wrench	55 mm	65 mm	75 mm
Cover for control mechanism / control mechanism (Allen screws / hexagon head screws)	C	in case of a repair	Allen key		17 mm 380 Nm	
AutoControl System	D	in case of a repair	Allen key		22 mm 300 Nm	
Percussion chamber ventilation	E	in case of a repair	open-ended wrench		41 mm 200 Nm	
PowerAdapt	F	in case of a repair	socket spanner		24 mm 300 Nm	
Ports »T«	G	weekly	open-ended wrench		60 mm 380 Nm	
Filling valve »G« (threaded plug)	H	in case of a repair	socket spanner Allen key		22 mm 130 Nm 5 mm 20 Nm	
Ports »P«	I	weekly	open-ended wrench		55 mm 285 Nm	
StartSelect (plug)	J	in case of a repair	Allen key		17 mm 200 Nm	
HP-accumulator*** (expansion bolts)	K	weekly	socket spanner		30 mm	
Flanges (Allen screws)	L	weekly	Allen key		10 mm 80 Nm	
Swivel joint covers (Allen screws)	M	daily	Allen key		10 mm 80 Nm	
Adapter plate under the HP-accumulator**** (Allen screws)	N	weekly	Allen key	20 mm	-	-
Hose connections ContiLube® II	-	weekly	Various open-ended spanners with different spanner sizes			

*	Apply anti-seize compound to the Allen screw threads before inserting them. The contact faces of the screw head and the lock washers must not be lubricated.
**HB 5800/DP	<ol style="list-style-type: none"> <li>1. Pre-tighten the tensioning bolts to 500 Nm crosswise,</li> <li>2. retighten 120° (2 hexagons) crosswise,</li> <li>3. retighten 180° (3 hexagons) crosswise</li> </ol>
**HB 7000/DP	<ol style="list-style-type: none"> <li>1. Pre-tighten the tensioning bolts to 500 Nm crosswise,</li> <li>2. retighten 180° (3 hexagons) crosswise,</li> <li>3. retighten 180° (3 hexagons) crosswise</li> </ol>
**HB 10000/DP	<ol style="list-style-type: none"> <li>1. Pre-tighten the tensioning bolts to 500 Nm crosswise,</li> <li>2. retighten 120° (2 hexagons) crosswise,</li> <li>3. retighten 120° (2 hexagons) crosswise,</li> <li>4. retighten 150° (2.5 hexagons) crosswise</li> </ol>
***	<p>Tightening regulations for expansion bolts on HP-accumulator:</p> <ol style="list-style-type: none"> <li>1. Treat the threads of the expansion bolts and the threaded inserts with Anti-Seize agent.</li> <li>2. Treat the surfaces between the expansion bolt head, washer, and HP-accumulator cover with Anti-Seize agent.</li> <li>3. Place on the HP-accumulator, and tighten the expansion bolts by hand in a crosswise fashion.</li> <li>4. Pretighten the expansion bolts to                      HB 5800/DP from SN 49 to 169 = 100 Nm                      HB 5800/DP from SN 170 = 80 Nm                      HB 7000/DP from SN 169 to 269 = 100 Nm                      HB 7000/DP from SN 270 = 80 Nm                      HB 10000/DP = 120 Nm, proceeding in a crosswise fashion.</li> <li>5. Tighten each expansion bolt through 30° in a crosswise fashion.</li> <li>6. Finally tighten each expansion bolt again through 60° in a crosswise fashion.</li> </ol>
****HB 5800/DP	<ol style="list-style-type: none"> <li>1. Treat the threads and threaded inserts for fixing screws with an Anti-Seize agent.</li> <li>2. Treat the surfaces between the bolt head and the adapter plate with Anti-Seize agent.</li> <li>3. Place on the adapter plate, and tighten the fixing screws by hand in a crosswise fashion.</li> <li>4. Tighten the fixing screws to 600 Nm, proceeding in a crosswise fashion</li> </ol>



HB 5800/DP

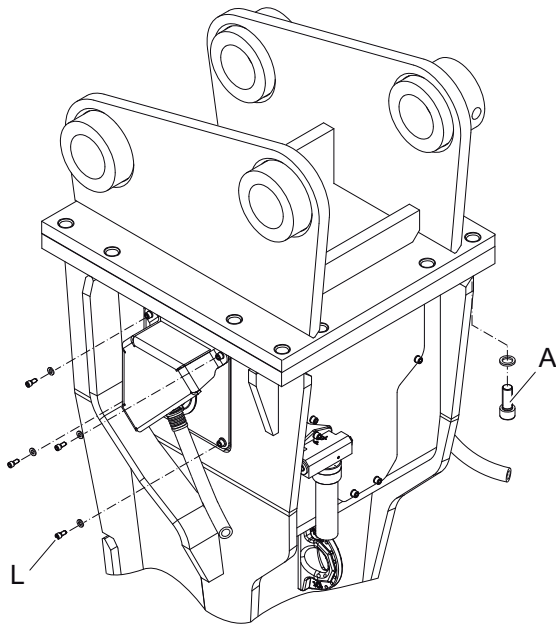

HB 7000/DP

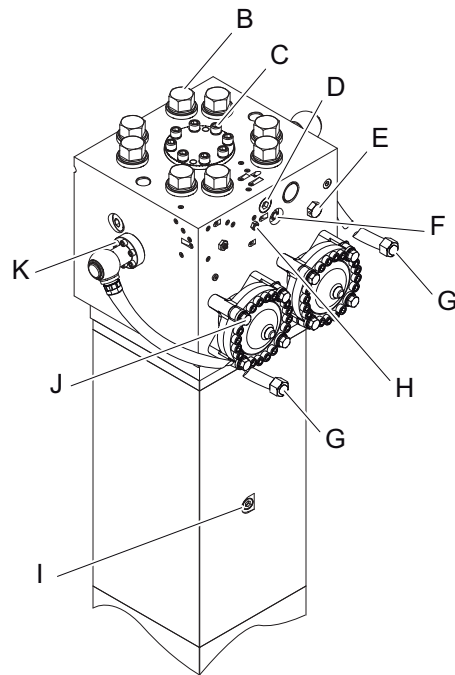
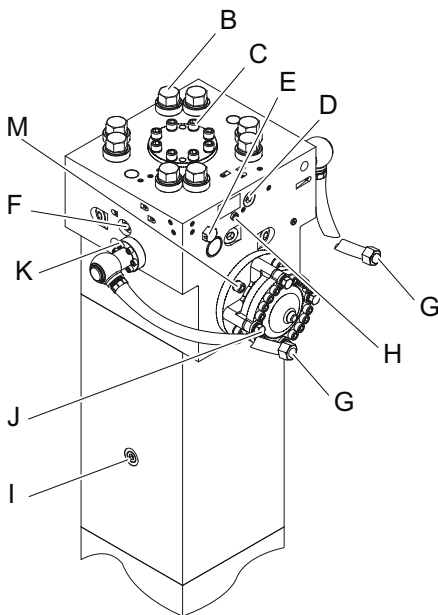
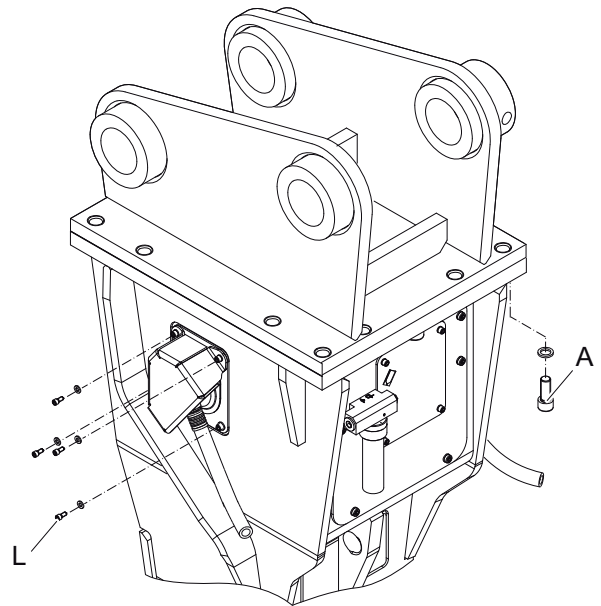

HB 10000/DP

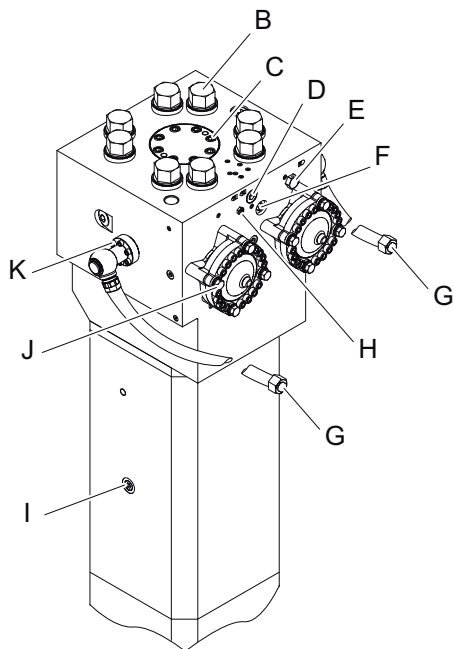
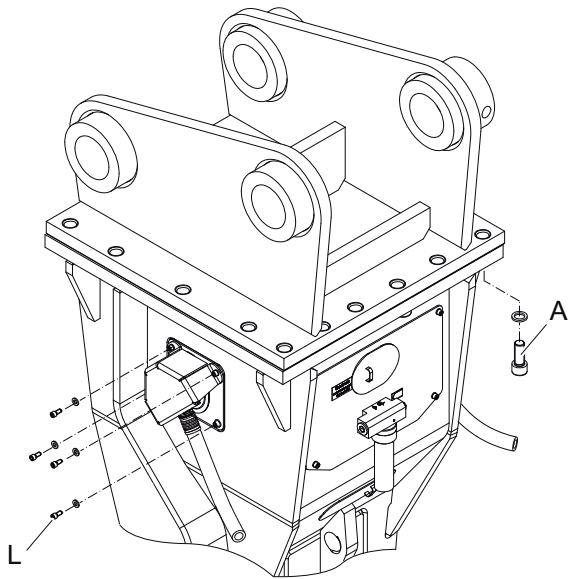

# TROUBLESHOOTING

## The hydraulic breaker does not start

Cause	Remedy	By
Pressure and tank lines swapped	Check the laying of the pressure and tank lines and connect correctly (see chapter <i>Making the hydraulic connections</i> )	Carrier driver
Shut-off valve in pressure and/or tank line closed	Check the shut-off valve and open	Carrier driver
Gas pressure in piston accumulator too high	Check the gas pressure in the piston accumulator and adjust it to the correct value (see chapter <i>Checking the pressure in the piston accumulator and Release the pressure from the piston accumulator</i> )	Carrier driver
Oil level in tank too low	Check the oil level and top up oil	Carrier driver
Defective couplings blocking pressure and tank lines	Check coupling and replace defective coupling halves	Workshop
Faults in the electrical system of the hydraulic breaker installation	Check the electrical system of the hydraulic breaker installation and clear faults	Workshop
Magnet on switch-on valve damaged	Replace the magnet	Workshop
Operating pressure too low	Check the carrier engine speed, the pump delivery and the pressure relief valve; check the operating pressure Adjust settings and replace defective parts if required	Carrier driver or Atlas Copco Customer Center/Dealer in your area
PowerAdapt active	Check the engine speed and/or mode stage of the carrier and lower as required (see chapter <i>PowerAdapt</i> )	Carrier driver

## Hydraulic breaker operates too slowly

Cause	Remedy	By
Insufficient hydraulic oil delivery volume	Check the engine speed and/or mode stage of the carrier and the operation pressure and adjust	Carrier driver
The connecting fitting in the pressure and tank line has come loose	Check the connecting fitting and tighten	Carrier driver
Check valve in pressure and/or tank line partly closed	Check the check valve and open	Carrier driver
Flow resistance on oil filter or oil cooler too high	Check the oil filter and oil cooler, clean or renew them	Carrier driver
Gas pressure in piston accumulator too high	Check the gas pressure in the piston accumulator and release some gas if required (see chapter <i>Checking the pressure in the piston accumulator and Release the pressure from the piston accumulator</i> )	Carrier driver
Working tool jams in the lower breaker part	Correct the direction of the carrier boom. The pressing force must act in the axial direction of the hydraulic breaker. Check the shaft of the working tool and deburr if required. Check the working tool and the wear bush for wear and replace if required (see chapter <i>Checking the working tool and Checking the wear bushes and impact ring</i> )	Carrier driver
Inside diameter of tank line too small	Check the inside diameter and change if required Observe the minimum inside diameter! (see chapter <i>Technical specifications</i> )	Workshop
Return pressure too high	Check and lower the return pressure	Atlas Copco Customer Center/Dealer in your area
Hydraulic oil return to the tank via a valve section	Connect the hydraulic oil return circuit directly to the tank or filter	Carrier driver or Atlas Copco Customer Center/Dealer in your area
Diaphragm in high-pressure accumulator defective (Hose at port »P« is flailing about wildly)	Replace the high-pressure accumulator Observe the national safety regulations!	Workshop
Hydraulic oil temperature in the tank higher than 80 °C	Check the oil level in the hydraulic tank and top up if required	Carrier driver
Hydraulic oil pressure too low	Check the pressure; adjust as required; Fit new type-tested pressure relief cartridges where necessary	Workshop

## Impact force too low

Cause	Remedy	By
Gas pressure too low	Check the gas pressure and fill the piston accumulator (see chapter <i>Filling/topping up the piston accumulator</i> )	Carrier driver
The pump of the hydraulic installation does not deliver sufficient oil	Check the pump characteristic with a measuring device and compare it to the original details; renew the pump if required	Checking: Atlas Copco Customer Center/Dealer in your area Replacing: by carrier manufacturer's customer service

## Impact rate too high and impact force too low

Cause	Remedy	By
No gas in piston accumulator	Check the gas pressure and fill the piston accumulator (see chapter <i>Filling/topping up the piston accumulator</i> )	Carrier driver
O-rings defective	Replace O-rings	Workshop

## Oil leaks from ports »P« und »T«

Cause	Remedy	By
Cap nuts loose	Check the cap nuts and tighten (see chapter <i>Bolt connections/Tightening torques</i> )	Carrier driver
Hose connection CL to port »P« for ContiLube® II or the plug is loose and ContiLube® II has not been installed	Check the cap nuts and tighten Check the plugs and tighten (see chapter <i>Bolt connections/Tightening torques</i> )	Carrier driver

## Oil escapes between the cylinder cover and the cylinder

Cause	Remedy	By
Tensioning bolts are loose	Check the tensioning bolts and tighten (see chapter <i>Bolt connections/Tightening torques</i> )	Workshop
Seals damaged	Replace the seals	Workshop

## Oil escapes from parts of the hydraulic breaker installation (connecting fittings, hoses etc.)

Cause	Remedy	By
Connecting fittings are loose; flange connections to the valve are loose	Check the connecting fittings and tighten; replace any defective parts if required (see chapter <i>Bolt connections/Tightening torques</i> ) Check the hydraulic breaker installation and replace any damaged parts Only use original parts!	Carrier driver or workshop

## Oil escapes from the working tool

Cause	Remedy	By
Lower piston seal defective	Dismantle the hydraulic breaker Replace the seals	Workshop

## Oil escapes from the high pressure accumulator

Cause	Remedy	By
The fastening screws of the high pressure accumulator are loose	Replace O-ring and back-up ring Tighten the fastening screws (see chapter <i>Bolt connections/Tightening torques</i> )	Workshop

## Oil or grease escapes from the ContiLube® II

Cause	Remedy	By
Connecting fittings are loose	Check the connecting fittings and tighten (see chapter <i>Bolt connections/Tightening torques</i> )	Workshop

## Operating temperature too high

Cause	Remedy	By
Oil level in tank too low	Check the oil level and top up oil	Carrier driver or workshop
Carrier pump delivery too high; a constant volume of oil is squirted out of the pressure relief valve	Check carrier engine speed and lower	Carrier driver
	Check carrier settings and adjust	Atlas Copco Customer Center/Dealer in your area
Operation in high outside temperature without oil cooler	Check oil temperature and install an oil cooler if required	Workshop or Atlas Copco Customer Center/Dealer in your area
Pressure relief valve defective or valve with poor characteristic	Fit new type-tested pressure relief cartridges or a more precise pressure-limiting valve	Workshop

# REPAIR

## ▲ **WARNING Risk of injury**

Nonprofessional disassembly and assembly of the hydraulic breaker may lead to serious injury and property damage.

- ▶ Never pull the percussion unit out of the breaker box. Dismounting the percussion unit is only permitted if carried out by professionals trained by Atlas Copco Construction Tools. These professionals must follow all safety instructions and guidelines for repair.
- ◆ For technical support contact the Atlas Copco Customer Center/Dealer in your area.

## **Sending in the hydraulic attachment for repairs**

---

### *NOTICE* Mixed hydraulic oil

Never mix mineral and non-mineral hydraulic oils! Even small traces of mineral oil mixed in with non-mineral oil can result in damage to both the hydraulic attachment and the carrier. Non-mineral oil loses its biodegradability.

- ▶ Only use one type of hydraulic oil.
- ◆ Always specify which hydraulic oil has been used when sending in the hydraulic attachment to have it repaired.

## STORAGE

### ▲ WARNING Hydraulic breaker / working tool fall

The hydraulic breaker and the working tool are heavy. If they topple over or fall down from where they are stored, injury may be the result.

- ▶ Store the hydraulic breaker and the tool so that they cannot topple over or fall down.

## Hydraulic breaker

The hydraulic breaker must be stored in an upright position to avoid its seals being damaged.

### Short storage

Proceed as follows in the case of storage for less than eight weeks:

- ◆ Remove the hydraulic breaker from the carrier (see chapter *Removing the hydraulic attachment from the carrier*).
- ◆ Store the hydraulic breaker in a dry, properly ventilated room.
- ◆ If you can only store the hydraulic breaker in the open air, cover it with plastic sheeting or tarpaulins to protect it against the weather.
- ◆ Store the hydraulic breaker in an upright position and so that it cannot topple over.

### Long storage

Proceed as follows if storage is expected to be for more than eight weeks:

- ◆ Remove the hydraulic breaker from the carrier (see chapter *Removing the hydraulic attachment from the carrier*).
- ◆ Remove the working tool (see chapter *Working tool/Removal*).
- ◆ Grease the working tool with chisel paste to prevent it corroding.
- ◆ Grease the wear bushes.
- ◆ Depressurise the piston accumulator (see chapter *Release the pressure from the piston accumulator*).
- ◆ Leave the filling hose in the filling valve to let the gas escape.

**NOTICE** Environmental damage due to hydraulic oil

Hydraulic oil is environmentally harmful and must not penetrate the ground or enter the water table or water supplies.

- ▶ Collect any hydraulic oil which escapes.
- ▶ Dispose of it in accordance with the applicable environmental regulations.

Oil may escape when pushing the percussion piston up.

- ◆ Remove the covers from the connection hoses.
- ◆ Slide the percussion piston into its upper stroke position.
- ◆ Slide the percussion piston retainer into the aperture for the working tool.
- ◆ Install the retainer bar.

The percussion piston has now been locked in its upper stroke position.

- ◆ Remove the filling hose from the filling valve.
- ◆ Seal the connection hoses with the covers.
- ◆ Seal the aperture for the working tool with the protective cap.
- ◆ Pull the filling hose out of the filling valve.
- ◆ Store the hydraulic breaker in a dry, properly ventilated room.
- ◆ Store the hydraulic breaker in an upright position and so that it cannot topple over.

### How to proceed after more than twelve months' storage

#### ▲ WARNING Risk of injury

Nonprofessional disassembly and assembly of the hydraulic breaker may lead to serious injury and property damage.

- ▶ Never pull the percussion unit out of the breaker box. Dismounting the percussion unit is only permitted if carried out by professionals trained by Atlas Copco Construction Tools. These professionals must follow all safety instructions and guidelines for repair.

The following measures are required to prevent premature hydraulic breaker failure, after it has been stored for over twelve months:

- ◆ Contact the Atlas Copco Customer Center/Dealer in your area.
- ◆ Professionals trained by Atlas Copco Construction tools will disassemble the hydraulic breaker properly and:



- check any parts liable to corrosion (percussion piston, cylinder, control) for corrosion damage.
- rework or replace corroded parts.
- replace all sealing elements.

## Working tool

---

- ◆ Grease the working tool with chisel paste to prevent it from corroding.
- ◆ Store the working tool in a dry, properly ventilated room.
- ◆ Store the working tool so that it cannot topple over or roll down.

## Grease cartridges

---

### **▲ WARNING Fire and harmful vapors**

Chisel paste can burn and cause serious fire. Harmful vapors are generated when chisel paste is burnt.

- ▶ Never store grease cartridges near fire-propagating or self-igniting substances.
- ▶ Do not expose the grease cartridges to direct sunlight.
- ◆ Store the grease cartridges in a cool, properly ventilated room.

## DISPOSAL

**NOTICE** Environmental damage due to consumables

Hydraulic oil and chisel paste are environmentally harmful and must not penetrate the ground or enter the water table or water supplies.

- ▶ Collect any such consumables which may escape.
- ▶ Dispose of them in accordance with the applicable environmental regulations.

## Hydraulic breaker

- ◆ Remove the hydraulic breaker from the carrier (see chapter *Removing the hydraulic attachment from the carrier*).
- ◆ Remove the working tool (see chapter *Working tool/Removal*).
- ◆ Remove the adapter plate (see chapter *Removing the adapter plate*).
- ◆ Remove the hydraulic hoses from the hydraulic breaker.
- ◆ Clean the hydraulic breaker (see chapter *Cleaning*).
- ◆ Dispose of the hydraulic breaker in line with all applicable regulations or consult an authorised and specialised recycling company.

## Hydraulic hoses

- ◆ Drain the hydraulic oil from the hydraulic hoses and collect it.
- ◆ Dispose of the hydraulic hoses in accordance with the applicable regulations to avoid environmental hazards.

## Hydraulic oil

- ◆ Collect any hydraulic oil which escapes.
- ◆ Dispose of it in accordance with the applicable environmental regulations.

## Chisel paste and grease cartridges

- ◆ Dispose of chisel paste and not completely emptied grease cartridges in accordance with the applicable regulations.
- ◆ Completely emptied grease cartridges can be recycled.

# TECHNICAL SPECIFICATIONS

	<b>HB 5800, HB 5800 DP</b>	<b>HB 7000, HB 7000 DP</b>	<b>HB 10000 DP</b>
Carrier weight class <sup>1)</sup>	58 - 100 t 127,868 - 220,462 lbs	70 - 120 t 154,324 - 264,555 lbs	85 - 140 t 187,393 - 308,647 lbs
Service weight <sup>2)</sup>	5,800 kg 12,787 lbs	7,000 kg 15,432 lbs	10,000 kg 22,046 lbs
Delivery weight (Standard version) <sup>4)</sup>	4,795 kg 10,571 lbs	5,800 kg 12,787 lbs	-
Delivery weight (DustProtector version) <sup>4)</sup>	4,965 kg 10,946 lbs	6,015 kg 13,261 lbs	7,870 kg 17,350 lbs
Oil flow rate	310 - 390 l/min 81.9 - 103.0 gal/min	360 - 450 l/min 91.1 - 118.9 gal/min	450 - 530 l/min 118.9 - 140.0 gal/min
Operating pressure	160 - 180 bar 2,320 - 2,610 psi	160 - 180 bar 2,320 - 2,610 psi	160 - 180 bar 2,320 - 2,610 psi
Impact rate	AutoControl 280 - 480 blows/min	AutoControl 280 - 450 blows/min	AutoControl 250 - 380 blows/min
Working tool diameter	200 mm 7.87 in.	210 mm 8.27 in.	240 mm 9.45 in.
Working length of working tool (Standard version)	865 mm 34.06 in.	935 mm 36.81 in.	-
Working length of working tool (DustProtector version)	810 mm 31.89 in.	885 mm 34.84 in.	880 mm 34.65 in.
Max. hydraulic input power	117 kW	135 kW	159 kW
Gas pressure HP- accumulator (20 °C)	60 bar	60 bar	60 bar
Air pressure (min. gauge pressure in percussion chamber) <sup>5)</sup>	1.5 bar	1.5 bar	1.5 bar
Air flow (up to depth of 10 meters) <sup>6)</sup>	7.5 m <sup>3</sup> /min	10 m <sup>3</sup> /min	15 m <sup>3</sup> /min
Max static pressure (pressure relief valve on carrier)	200 bar	200 bar	200 bar
Piston accumulator gas pressure (min, at operating temperature 60-70 °C) <sup>7)</sup>	9.4 bar	9.0 bar	9.0 bar
Piston accumulator gas pressure (max (optimum), at operating temperature 60-70 °C) <sup>7)</sup>	12.5 bar	11.5 bar	11.1 bar
Hose inside diameter »P«	32 mm 1.26 in.	32 mm 1.26 in.	32 mm 1.26 in.
Hose inside diameter »T«	40 mm 1.58 in.	40 mm 1.58 in.	40 mm 1.58 in.
Start up mode	StartSelect	StartSelect	StartSelect
Part number (Standard version)	3363 0904 73	3363 0904 81	-
Part number (DustProtector version)	3363 0904 75	3363 0904 83	3363 1003 91

<sup>1)</sup> Weights apply to standard carriers only. Any variances must be agreed with Atlas Copco and/or the carrier manufacturer prior to attachment

<sup>2)</sup> Hydraulic breaker incl. breaker box, working tool and adapter plate of medium size.

Please note that the service weight can be considerably higher, depending on the adapter plate.

<sup>4)</sup> Hydraulic breaker, breaker box and ContiLube® II without working tool and adapter plate

<sup>5)</sup> Air pressure at pressure regulator has to be adjusted to 1.5 bar plus 0.1 bar per meter depth

<sup>6)</sup> Air flow for depth of more than 10 meters: Flow = 0.1 x depth [m] x flow up to 10 meters [m<sup>3</sup>/min]

<sup>7)</sup> Hydraulic breaker in horizontal position, no pressure applied to working tool

## Noise declaration statement

	<b>HB 5800, HB 5800 DP</b>	<b>HB 7000, HB 7000 DP</b>	<b>HB 10000 DP</b>
Sound pressure <sup>1</sup> dB(A)	92	92	93
Sound power <sup>2</sup> dB(A)	121	121	123

<sup>1</sup> Sound pressure level according to EN ISO 3744 in accordance with directive 2000/14/EC at 10 metres distance.

<sup>2</sup> Guaranteed sound power according to EN ISO 3744 in accordance with directive 2000/14/EC inclusive spread in production.

These declared values were obtained by laboratory type testing in accordance with the stated directive or standards and are suitable for comparison with the declared values of other tools tested in accordance with the same directive or standards. These declared values are not adequate for use in risk assessments and values measured in individual work places may be higher. The actual exposure values and risk of harm experienced by an individual user are unique and depend upon the way the user works, in what material the breaker is used, as well as upon the exposure time and the physical condition of the user, and the condition of the breaker.

We, Atlas Copco, cannot be held liable for the consequences of using the declared values, instead of values reflecting the actual exposure, in an individual risk assessment in a work place situation over which we have no control.

## EC Declaration of Conformity (EC Directive 2006/42/EC)

We, Atlas Copco Construction Tools GmbH, hereby declare that the machines listed below conform to the provisions of EC Directive 2006/42/EC (Machinery Directive) and 2000/14/EC, ANNEX V (Noise Directive) and 97/23/EC (Pressure Equipment Directive), and the harmonised standards mentioned below.

Hydraulic Breaker	Part number	Guaranteed sound power level [dB(A)]	Measured sound power level [dB(A)]
HB 5800	3363 0904 73	121	120
HB 5800 DP	3363 0904 75	120	120
HB 7000	3363 0904 81	121	120
HB 7000 DP	3363 0904 83	121	120
HB 10000 DP	3363 1003 91	123	121

### Following harmonised standards were applied:

- ◆ EN ISO 12100
- ◆ EN ISO 3744

### Technical Documentation authorised representative:

Stephan Schröer  
Atlas Copco Construction Tools GmbH  
45143 Essen  
Germany

### General Manager:

Lothar Sprengnetter

### Manufacturer:

Atlas Copco Construction Tools GmbH  
45143 Essen  
Germany

### Place and date:

Essen, 2012-05-02





Any unauthorized use or copying of the contents or any part thereof is prohibited.  
This applies in particular to trademarks, model denominations, part numbers, and  
drawings.

© 2012 Atlas Copco Construction Tools GmbH | No. 3390 5005 01 | 2012-05-03

**Atlas Copco**

[www.atlascopco.com](http://www.atlascopco.com)