

MODEL RANGE

FH 16 8x2 Rigid - Pusher & Tag Tridem – contact sales engineering reference

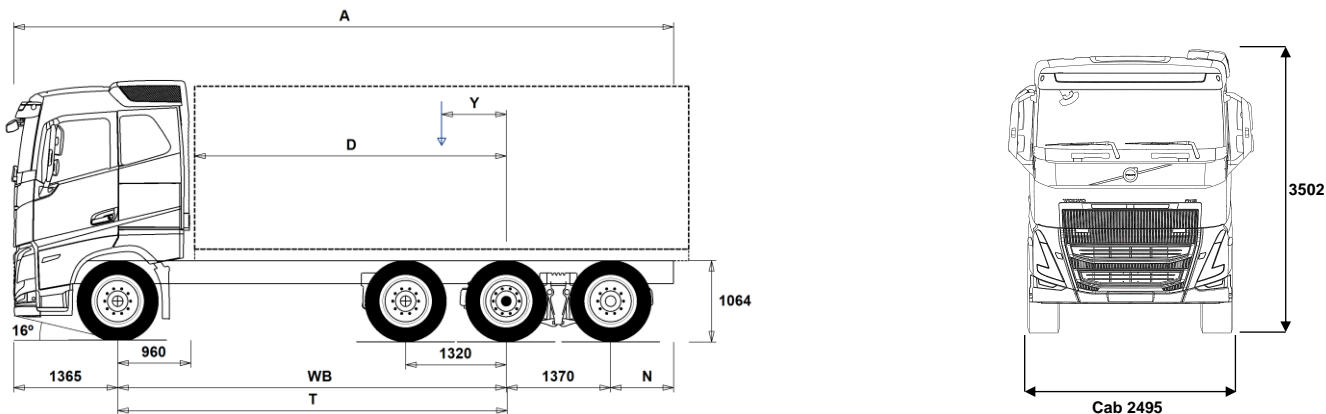

Chassis Dimensions [mm]

WB Wheelbase	5100	5600
A Overall Chassis Length	10060	10460
D Center of rear axle to front of body	4090	4590
N Rear Overhang (Min.)	825	825
N Rear Overhang (Max.)	2225	2125
T Theoretical Wheelbase	5114	5614
Y Center of Gravity for Payload (Min.)	525	570
Y Center of Gravity for Payload (Max.)	525	570

Chassis Weights [kg]

Front Axle	5595	5630
Rear Bogie	3530	3530
Kerb Weight	9125	9160
Payload (including body, driver, fuel, etc.)	22875	22840

Turning Diameter [mm]

Turning Circle Diameter Kerb to Kerb	20100	21700
Turning Circle Diameter Wall to Wall	21400	23100

Plated Weights [kg]

	Plated	Design
Gross Vehicle Weight	32000	36000
Gross Combination Weight	44000	44000
Front Axle	8000	9000
Rear Bogie	24000	27000

Important Notes

Chassis Dimensions

Cab Height: +305 mm for CAB-HSLP, -285 mm for CAB-LSLP, +450 mm for CAB-XHSL.

Front Axle to Back of Cab: +121 mm for CAB-LSLP.

D-measure includes a front clearance of 50 mm and for rigid trucks also a subframe of 100 mm.

Height can vary ± 20 mm for leaf and ± 10 mm for air suspension.

All dimensions are for unladen chassis and any tag axles down. Chassis height used: CHH-HIGH.

Rear overhang used for vehicle weight calculation is the maximum rear overhang (N Max.) for selected wheelbase.

Height change when chassis height CHH-MED,FRAME300: 0 mm.

Weight and dimensions are based upon the following tyres:

Front Axle Tyres:	315/80R22.5
Drive Axle Tyres:	315/80R22.5
Trailing/Pusher Axle Tyres:	315/80R22.5

Chassis weight includes oil, water, AdBlue, 0 litres fuel and without driver. Kerb weight can vary ± 3%.

Turning diameters are theoretically calculated. Tag axle used: TA-FIXED.

Legal weights can differ from country to country.

For more detailed weight information, including optional equipment weights, ask your Volvo sales contact to enter your specification into the Volvo Weight Information system (WIS).

Do NOT use this drawing for bodybuilding. Refer to Volvo Bodybuilder Instructions and chassis assembly drawing FH82RPT6A.

MODEL RANGE

FH 16 8x2 Rigid - Pusher & Tag Tridem – contact sales engineering reference

TRUCK USE

- RC-ROUGH** Road conditions - On / off-road
- RC-SMOOTH** Road Conditions - Smooth
- TIPP-PRE** Transport Adaption - Tipper vehicle preparation
- UNIFORM** Transport Adaption - Basic platform vehicle

CORE COMPONENTS

- CHH-HIGH** Chassis Height - High - for loading heights check the unique BEP chassis drawing attached to this quote
- CHH-MED** Chassis Height - Medium - for loading heights check the unique BEP chassis drawing attached to this quote
- PT-TEHYS** Pusher-tag tridem - Electro hydraulic steered pusher and tag axle, both with single wheel mounting
- PT-TFIXD** Pusher-tag tridem - Electro hydraulic steered pusher with fixed tag/dual wheel mounting
- RAPDT-GR** Rear air suspension, 3 axles - 1 pusher/1 driven/1 tag
- FH16HSL5** Globetrotter cab - all steel safety cage design with roof mounted emergency escape hatch. Designed and built to Swedish impact and ECE R29 regulations
- FH16LSL5** Low Sleeper Cab
- FH16SLP5** Cab - Sleeper - all-steel safety cage design with roof-mounted emergency escape hatch. Designed and built to Swedish impact and ECE R29 regulations
- FH16XHS5** Globetrotter XL cab - all steel safety cage design with roof mounted emergency escape hatch. Designed and built to Swedish impact and ECE R29 regulations
- EU6DS** Euro 6 SCR, particulate filter, EGR and dual stage turbo
- D16K550** Engine - D16K550 16 litre developing 550hp at 1550-1900rpm SCR & EGR. Peak torque 2900Nm at 900-1350rpm. 2800Nm at 900-1400rpm with manual gearbox
- D16K650** Engine - D16K650 16 litre developing 650hp at 1450-1900rpm SCR & EGR. Peak torque 3150Nm at 950-1450rpm.
- D16K750** Engine - D16K750 16 litre developing 750hp at 1600-1800rpm SCR & EGR. Peak torque 3550Nm at 950-1400rpm.
- EBR-VEB+** Engine Brake Type - Volvo engine brake + and exhaust pressure governor, enhanced performance from additional exhaust rocker control. Retardation 375kW
- AT2812** Gearbox - AT2812 12-speed I-Shift automated mechanical suitable for gross train weights up to 60 tonne. Refer to sales engineering when used in conjunction with a PTO
- ATO3112** Gearbox - ATO3112 12-speed I-Shift overdrive automated mechanical, suitable for gross train weights up to 60tonne. Refer to sales engineering when used in conjunction with a PTO
- ATO3512** Gearbox - ATO3512 12-speed I-shift automated mechanical, suitable for gross train weights up to 60 tonne. Refer to sales engineering when used in conjunction with a PTO
- ASO-C** Crawler gear - Ratio direct top gearbox 19:1 Ratio Overdrive gearbox 17:1
- ASO-ULC** Ultra low crawler and crawler gear - Ratios direct top gearbox 32:1 and 19:1 Ratios Overdrive box 32:1 and 17:1
- RSH1370F** Drive Axle - RSH1370F 13-tonne hub reduction with differential lock - design GCW 70 tonne
- RSS1370A** Drive Axle - RSS1370A single reduction 13 tonne with differential lock - design GCW 70 tonne
- RSS1370B** Drive Axle - RSS1370B single reduction 13 tonne with differential lock - design GCW 70 tonne

PACKAGES

- DRIVE16** Cab Package - Drive +

- 1LIVIN++** Sleep & Resting Package - Living one-bed ++
- 1LIVING** Sleep & Resting Package - Living one-bed
- 1LIVING+** Sleep & Resting Package - Living one-bed +
- 2LIVIN++** Sleep & Resting Package - Living two-bed ++
- 2LIVING** Sleep & Resting Package - Living two-bed
- 2LIVING+** Sleep & Resting Package - Living two-bed +
- INFOBAS** Basic media package without secondary display
- INFODF** Media Information Platform with Dynafleet Support
- INFOMED** Media Information Platform - Medium level
- INFONAV** Media Information Platform with Navigation
- INFONDF** Media Information Platform with Navigation & Volvo Connect "On board" Support
- VISI5+** Visibility+ Package
- VISI5++** Visibility++ Package
- VISIC5** Visibility Package
- VISIC5+** Visibility+ Package
- SAFE22** Safety package
- SAFE22+** Safety Package +
- CHASPAC** Chassis Package Rigid
- CHASSIS**
 - FST-AIR** Front suspension type - Air
 - FST-PAR** Front suspension type - 2 leaf parabolic springs
 - FST-PAR3** Front suspension type - 3 leaf parabolic springs
 - FSL5-BAS** Front suspension levelling - basic stroke
 - FSL5-HI** Front suspension levelling - high stroke for demount operations - check with bodybuilder
 - FAL10.0** Front axle design capacity - 10 tonne - check tyre capacity
 - FAL9.0** Front axle design capacity - 9.0 tonne - check tyre capacity
 - FSM-LUB** Front suspension maintenance - Lubricated rear shackles on pins and bushings
 - FSTAB** Front anti-roll bar - Normal stiffness
 - FSTAB2** Front anti-roll bar - Medium stiffness
 - FSTAB3** Front anti-roll bar - High stiffness
 - RAL27** Rear bogie design capacity - 27 tonne
 - RAL30** Rear Bogie Design Capacity - 30 tonne
 - RAL30.5** Rear Bogie Design Capacity - 30.5 tonne
 - RAL31.5** Rear Bogie Design Capacity - 31.5 tonne
 - RAL32** Rear bogie design capacity - 32 tonne
 - RALIM105** Rear-axle load limiter - 10.5 tonne - speed controlled
 - RALIM115** Rear-axle load limiter -11.5 tonne - speed controlled
 - RALIM13** Rear-axle load limiter - 13 tonne
 - ACTST-TO** Active Steering- Volvo Dynamic Steering - VDS - with extra electronic pump and torque overlay
 - ASFE-BAS** Active steering feature - Basic - Volvo Dynamic Steering - VDS - only
 - ASFE-OG** Active steering feature - Volvo Dynamic Steering - VDS - with stability assist - oversteer
 - ASFE-PO** Active steering feature - Volvo Dynamic Steering - VDS - with personal settings and stability assist
 - ASFE-PS** Active steering feature - Volvo Dynamic Steering - VDS - with personal settings
 - PSS-DUAL** Power steering system - Dual
 - PSS-SING** Power steering system - Single
 - AUXPSP** Extra power steering pump driven by the engine PTO (PTER-DIN) so an adapter is required to drive any other equipment.
 - PSP-VAR** Power steering pump - Variable displacement
 - EBS-MED** Brake package - EBS medium including "hill" hold function
 - RST-AIR** Rear suspension type - Air
 - SUSPL-EC** Remote electronic control on wander-lead for air suspension levelling
 - FRAME300** Chassis frame section external height - 300 mm
 - FST8080** Chassis frame thickness - 8 mm web and flange

- Standard Equipment
- Optional Equipment

For more detailed information about cab and powertrain equipment, please refer to separate specification sheets.

For all possible options and combinations of options please consult your Volvo sales contact who can create a specification to match your requirements using the Volvo Sales Support system (VSS).

The factory reserves the right to modify design and change equipment without previous notification. The specification can vary from country to country.

MODEL RANGE

FH 16 8x2 Rigid - Pusher & Tag Tridem – contact sales engineering reference

<input type="checkbox"/> FIL-EEEB	Chassis frame inner liner - From the end of the engine to the end of the bogie	<input type="checkbox"/> TOWMBRL1	Towing member, low mounted under the frame
<input type="checkbox"/> FIL-EEEF	Chassis frame inner liner - From the end of the engine to end of the frame	<input type="checkbox"/> TOWMBRM	Towing member, medium mounted in line with frame lower flange
<input type="checkbox"/> FIL-TXEB	Chassis frame inner liner - From gearbox member to the end of the bogie	<input checked="" type="checkbox"/> RFEC-S	Rear frame profile - Straight cut
<input type="checkbox"/> FIL-TXEF	Chassis frame inner liner - From gearbox member to the end of the frame	<input type="checkbox"/> RFEC-U	Rear frame profile - Slight uppercut for tippers
<input type="checkbox"/> BATS-D	Dual energy battery system - 2 living batteries and 2 starter batteries.	<input type="checkbox"/> C-RI4040	Towing coupling, Ringfeder 4040A
<input checked="" type="checkbox"/> BATS-S	Single energy battery system (2 batteries)	<input type="checkbox"/> C-RI5050	Towing coupling, Ringfeder 5050A
<input type="checkbox"/> 2BAT210B	Battery Capacity - 2 x 210 Ah - Gel type	<input type="checkbox"/> C-RO400G	Towing coupling, Rockinger 400 G-150 for 40mm eyes
<input checked="" type="checkbox"/> 2BAT210C	Battery Capacity - 2 x 210 Ah - AGM Absorbent Glass-fibre Material type	<input type="checkbox"/> C-RO50	Rockinger RO 50 50mm for centre axle trailer
<input checked="" type="checkbox"/> BATTAMP	Battery management - Voltage and current gauge	<input type="checkbox"/> C-VBG795	VBG 795V-3 coupling (centre axle trailer)
<input type="checkbox"/> BATTIND	Battery management - Voltage, current and charge indicators	<input type="checkbox"/> TOWR-ONE	Towing hitch attached to rear crossmember
<input type="checkbox"/> ADR2	ADR Adaptation - For transportation of dangerous goods on the road - Note does NOT include safe loading pass package if required this is quoted separately	<input checked="" type="checkbox"/> TREL-PK	Trailer electrical preparation kit - chassis/cab wiring
<input type="checkbox"/> MSWI-A	Battery master switch - ADR switch circuit shut down	<input type="checkbox"/> TREL14	Single 14 pole electrical trailer connector
<input checked="" type="checkbox"/> MSWI-C	Battery master switch - Chassis mounted toggle by the battery box	<input type="checkbox"/> TREL15	Trailer electrical connection - Single 15 pin - ADR certified
<input type="checkbox"/> MSWI-R	Battery master switch - Key fob operated remote controlled	<input type="checkbox"/> TREL7	7 pole - 24N trailer electrical suzie
<input checked="" type="checkbox"/> R330A71	Right fuel tank - 330litre aluminium diameter 710mm Min volume 210l Max volume 810l	<input type="checkbox"/> TREL7-7	Trailer electrical connection - 2 x 7 pin - 24N and 24S
<input checked="" type="checkbox"/> UL-FUEL	Left fuel tank - Without Min volume 160l Max volume 730l	<input type="checkbox"/> TBC-DUO	Trailer brake connections - Duomatic type
<input type="checkbox"/> ADTP-L	AdBlue tank position - Chassis mounted on the left-hand side	<input type="checkbox"/> TBC-EC	Trailer brake connections - EC palm coupling connectors
<input checked="" type="checkbox"/> ADTP-R	AdBlue tank position - Chassis mounted on the right-hand side	<input type="checkbox"/> TRBR-HCF	Full pressure hand controlled trailer brake
<input type="checkbox"/> ADB048	Plastic AdBlue tank - 48 litre	<input type="checkbox"/> TRBR-STA	Stationary trailer brake control
<input checked="" type="checkbox"/> ADB064	Plastic AdBlue tank - 64 litre	<input type="checkbox"/> TRB-STRE	Stretch Brake - Automatic low speed trailer brake activation to avoid jack-knifing and improve steerability
<input type="checkbox"/> ADB068	Plastic AdBlue tank - 68 litre	<input type="checkbox"/> RFEND-B	Rear mud wings - Three piece EC approved and spray flaps
<input type="checkbox"/> ADB083	Plastic AdBlue tank - 83 litre	<input type="checkbox"/> RFEND-T	Rear mud wings - Temporary on drive axle for transport delivery only
<input type="checkbox"/> ADB090	Plastic AdBlue tank - 90 litre	<input type="checkbox"/> RFH-BAS	Basic rear wing height
<input type="checkbox"/> ADB112	Plastic AdBlue tank - 112 litre	<input type="checkbox"/> RFH-HIG	High rear wing height - higher wing tops
<input type="checkbox"/> ADTC-BF	AdBlue tank cover with satin alloy look decorative cover	<input type="checkbox"/> RFH-LOW	Lower rear wing height - shallower wing tops
<input checked="" type="checkbox"/> FCAP-L	Diesel and AdBlue filler cap - Locking	<input type="checkbox"/> ATANK-AL	Air tanks - Aluminium
<input checked="" type="checkbox"/> FUFF-AS	Fuel filler - Anti-spill device	<input checked="" type="checkbox"/> ATANK-ST	Air tanks - Steel
<input type="checkbox"/> FUFF-ATS	Fuel filler - Anti-spill & anti-syphon device	<input checked="" type="checkbox"/> TL-LED	Rear lights - LED
<input type="checkbox"/> ESH-LEFT	Exhaust - Horizontal silencer - left outlet	<input checked="" type="checkbox"/> BLIGHT-E	Emergency brake light
<input checked="" type="checkbox"/> ESH-REAR	Exhaust - Horizontal silencer - rear outlet	WHEELS & TYRES	
<input type="checkbox"/> ESH-RIGH	Exhaust - Horizontal silencer - right outlet	<input type="checkbox"/> RT-AL	Wheels - Alcoa brushed aluminium rims - standard holes for long stud fixing
<input type="checkbox"/> ESH-VERT	Exhaust - Horizontal silencer - vertical outlet	<input type="checkbox"/> RT-ALDP	Wheels - Alcoa Dura-Bright aluminium rims - standard holes for long stud fixing
<input type="checkbox"/> EXST-SSP	Stainless steel exhaust stack - NOT polished	<input type="checkbox"/> RT-ALDPD	Wheels - Alcoa Dura-Bright EVO aluminium rims - countersunk holes for short stud fixing
<input type="checkbox"/> EXST-ST	Steel exhaust stack	<input type="checkbox"/> RT-ALDU	Wheels - Alcoa brushed aluminium rims - countersunk holes for short stud fixing
<input type="checkbox"/> HS-NAR	Narrow heat shield	<input checked="" type="checkbox"/> RT-STEEL	Wheels - Steel rims
<input type="checkbox"/> WHC-FIX2	Wheel chocks - Two fixed design	<input type="checkbox"/> WCAP	Aerodynamic hub caps
<input type="checkbox"/> WHC-FOL2	Two foldable wheel chocks	<input type="checkbox"/> SPWT-D	Spare wheel & tyre with rear tyre pattern
<input type="checkbox"/> WHCP-F	Wheel chock carrier position - In the front part of the vehicle	<input type="checkbox"/> SPWT-F	Spare wheel & tyre with front tyre pattern
<input type="checkbox"/> WHCP-M	Wheel chock carrier position - Middle part of the vehicle	<input type="checkbox"/> SWCP-LF	Spare wheel carrier on left side of chassis ahead of rear axle
<input type="checkbox"/> WHCP-R	Wheel chock carrier position - In the rear part of the vehicle	<input type="checkbox"/> SWCP-R	Rear mounted spare wheel carrier
<input type="checkbox"/> WHCP-T	Wheel chock carrier position - Outer luggage locker	<input type="checkbox"/> SWCP-T	Spare wheel supplied temporarily strapped to chassis
<input type="checkbox"/> TB-R80	Toolbox 800 mm, right side	<input type="checkbox"/> SWCP-TP	Temporary spare wheel carrier on top of chassis frame
<input type="checkbox"/> SUP-BAS	Side guards - Check with bodybuilder chassis space requirements	<input type="checkbox"/> JACK-12T	12 tonne bottle jack
<input type="checkbox"/> CHAIN-S	Snow chains	<input type="checkbox"/> JACK-15T	15 tonne bottle jack
<input type="checkbox"/> HOOK-SC	Snow chain hooks	<input type="checkbox"/> JACK-20T	20 tonne bottle jack
<input checked="" type="checkbox"/> TOWF-NO1	Front towing device - One detachable - stored in cab	<input checked="" type="checkbox"/> TOOL-BAS	Toolkit - Basic
<input type="checkbox"/> TOWF-NO2	Front towing device - Two detachable - stored in cab	<input type="checkbox"/> TOOLKIT	Toolkit - Complete
<input type="checkbox"/> TOWMBRH	Towing member, high mounted in centre of frame, D = 190	<input type="checkbox"/> INFLAHOS	Tyre inflation hose
		<input type="checkbox"/> GAUGE-TP	Tyre pressure gauge

Standard Equipment

Optional Equipment

For more detailed information about cab and powertrain equipment, please refer to separate specification sheets.

For all possible options and combinations of options please consult your Volvo sales contact who can create a specification to match your requirements using the Volvo Sales Support system (VSS).

The factory reserves the right to modify design and change equipment without previous notification. The specification can vary from country to country.

MODEL RANGE

FH 16 8x2 Rigid - Pusher & Tag Tridem – contact sales engineering reference

<input type="checkbox"/> CRUIS-E	Cruise control - with I-roll and I-cruise, controls in steering wheel	<input type="checkbox"/> PTRD-D1	PTRD-D1 Gearbox driven HIGH SPEED PTO (1 SAE flange & 1 plug-in hydraulic pump)
<input checked="" type="checkbox"/> CRUIS-E5	Eco torque software - Improved economy mode. Fuel economy optimized cruise control for I-Save	<input type="checkbox"/> PTRD-D2	Gearbox driven HIGH SPEED PTO (2 SAE flanges & 1 plug-in hyd pump)
<input type="checkbox"/> AMSO-AUT	Enhanced I-shift software with manual shift available in auto mode and kickdown facility on accelerator pedal	<input type="checkbox"/> PTRD-F	PTO with 1 DIN + 1 flange connection rear, manual gearbox
<input type="checkbox"/> AVO-ENH	I-Shift application software - Construction and off road applications	<input type="checkbox"/> HPG-F101	Parker F1-101 gearbox mounted, fixed displacement, single flow, hydraulic pump
<input type="checkbox"/> APF-ENH	I-shift enhanced PTO functions	<input type="checkbox"/> HPG-F41	Parker F1-41 gearbox mounted, fixed displacement, single flow, hydraulic pump
<input type="checkbox"/> RET-TH	Gearbox mounted retarder	<input type="checkbox"/> HPG-F51	Parker F1-51 gearbox mounted, fixed displacement, single flow, hydraulic pump
<input type="checkbox"/> TC-MAOH2	Extra high performance transmission oil cooler - air to oil with front mounted radiator	<input type="checkbox"/> HPG-F61	Parker F1-61 gearbox mounted, fixed displacement, single flow, hydraulic pump
<input type="checkbox"/> TC-MWO	Basic transmission oil cooler - water to oil	<input type="checkbox"/> HPG-F81	Parker F1-81 gearbox mounted, fixed displacement, single flow, hydraulic pump
<input type="checkbox"/> 2COM1100	Air compressor - Two-cylinder 1100 litres per minute	<input checked="" type="checkbox"/> STWPOS-R	Steering wheel position - RIGHT-HAND DRIVE
<input checked="" type="checkbox"/> 2COMP900	Air compressor - Two-cylinder 900 litres per minute	<input checked="" type="checkbox"/> STWM-LE	Steering wheel - Leather rim
<input type="checkbox"/> CLU-AIRC	Clutchable air compressor	<input type="checkbox"/> STGW-AD2	Steering wheel adjustment - Neck tilt, column height and angle
<input type="checkbox"/> AIRIN-FR	Front air intake fitted to the underside of cab engine tunnel	<input checked="" type="checkbox"/> STGW-ADJ	Steering wheel adjustment - Column height and angle
<input checked="" type="checkbox"/> AIRIN-HI	Air intake - Roof-mounted behind cab on the left-hand side	<input checked="" type="checkbox"/> AIRBAG	Driver air bag
<input type="checkbox"/> AIRIN-LO	Low level air intake behind cab on left hand side	<input type="checkbox"/> INST-BAS	Basic level instruments
<input type="checkbox"/> ACL1ST-S	Air filter - two-stage element	<input checked="" type="checkbox"/> DRC-AMII	DPF Regeneration control switch - for manual and switching off regeneration
<input checked="" type="checkbox"/> 24A150BL	Alternator capacity - 150 amp	<input checked="" type="checkbox"/> 1DAYDIG2	Tachograph - Continental VDO 4.0
<input type="checkbox"/> 24A180BL	Alternator capacity - 180 amp	<input type="checkbox"/> ARSL	Additional road speed limit - switch in dashboard
<input type="checkbox"/> 24AL150B	Alternator capacity - 150 amp	<input type="checkbox"/> ESP-BAS1	Electronic Stability Control ESC
<input type="checkbox"/> CCV-C	Closed crankcase engine ventilation	<input type="checkbox"/> ESPC-RO	Additional ESC functions - Reduced / Off
<input checked="" type="checkbox"/> CCV-OX	Closed crankcase ventilation for cold markets	<input type="checkbox"/> HWSS-AC	Adaptive cruise control with forward collision warning
<input checked="" type="checkbox"/> PRIM-EL	Electrical priming pump	<input type="checkbox"/> HWSS-ACB	Adaptive cruise control ACC with forward collision warning and AEBS advanced emergency brake system
<input type="checkbox"/> AF-R	Hot fuel recirculation heated fuel filter	<input type="checkbox"/> HWSS-FCB	Forward collision warning with AEBS advanced emergency brake system
<input checked="" type="checkbox"/> FUEFE2SW	Small engine mounted dual fuel filter with water separator	<input type="checkbox"/> LSS-DW	Lane departure-warning system
<input type="checkbox"/> EST-AID	Engine starting aid -Preheating element in the air inlet manifold	<input type="checkbox"/> LCS	Lane change support
<input type="checkbox"/> 220EBH15	220V/1.5Kw electric engine block heater	<input type="checkbox"/> LCS4	Side Collision Avoidance Support - passenger and driver side
<input type="checkbox"/> PTER-100	Engine power-take-off - Rear-mounted with DIN100/ISO7646 flange	<input type="checkbox"/> DAS-W	Driver Alert Support system
<input type="checkbox"/> PTER-DIN	Engine power-take-off - Rear-mounted with DIN5462 (female) splined shaft for a close-coupled pump Models with 3 steering axles will use this to drive the steering pump (AUXPSP)	<input type="checkbox"/> RSENS-W	Rain sensing windscreen wipers
<input type="checkbox"/> PTER1400	Engine power-take-off - Rear-mounted with SAE 1410 flange	<input checked="" type="checkbox"/> CU-ECC	Cab Climate Unit - Electrically controlled air conditioning with sun sensor
<input type="checkbox"/> HPE-F101	Parker F1-101, engine mounted, fixed displacement, single flow, engine mounted hydraulic pump	<input type="checkbox"/> CU-ECC2	Cab Climate Unit - Electrically controlled air conditioning with a carbon filter, sun, mist, and air quality sensor
<input type="checkbox"/> HPE-F41	Parker F1-41, engine mounted, fixed displacement, single flow, engine mounted hydraulic pump	<input checked="" type="checkbox"/> IMMOBIL	Thatcham H2 approved immobiliser
<input type="checkbox"/> HPE-F51	Parker F1-51, engine mounted, fixed displacement, single flow, engine mounted hydraulic pump	<input type="checkbox"/> ALARM-E	Vehicle alarm - Cab plus external sensor for body/trailer
<input type="checkbox"/> HPE-F61	Parker F1-61, engine mounted, fixed displacement, single flow, engine mounted hydraulic pump	<input type="checkbox"/> AMPL400	Radio amplifier, 8 channel, 400 W with subwoofer Located in right hand external storage box
<input type="checkbox"/> HPE-F81	Parker F1-81, engine mounted, fixed displacement, single flow, engine mounted hydraulic pump	<input type="checkbox"/> BUPMON	Back up monitor - Digital reverse camera, parameter & lead supplied loose in cab.
<input type="checkbox"/> HPE-T53	Parker F2-53/53, engine mounted, Fixed displacement, Twin flow engine mounted hydraulic pump	<input type="checkbox"/> PHONE-PK	Telephone preparation kit (antenna, antenna attachm. cable incl.)
<input type="checkbox"/> HPE-T70	Parker F2-70/35, engine mounted, Fixed displacement, Twin flow engine mounted hydraulic pump	<input type="checkbox"/> ISUNS-BS	Side sun visor - Driver & passenger side
<input type="checkbox"/> HPE-V45	Parker VP1-45, variable displacement, single flow, engine mounted hydraulic pump	<input checked="" type="checkbox"/> ISUNS-DS	Side sun visor - Driver-side
<input type="checkbox"/> HPE-V75	Parker VP1-75, variable displacement, single flow, engine mounted hydraulic pump	<input type="checkbox"/> ISUNF-RE	Electrically operated textile interior sun blind
<input type="checkbox"/> PTR-D	Gearbox PTO for plug-in pump, 0.71xeng speed	<input checked="" type="checkbox"/> ISUNF-RM	Manually operated textile interior sun blind
<input type="checkbox"/> PTR-DH	Gearbox driven high speed PTO for one plug-in hydraulic pump	<input checked="" type="checkbox"/> CSPL-BX	Lower center dash open storage box
<input type="checkbox"/> PTR-DM	Gearbox driven medium speed PTO for one plug-in hydraulic pump	<input type="checkbox"/> CSPL-BXD	Lower centre dash drawer
<input type="checkbox"/> PTR-F	Gearbox driven PTO with rear flange connection	<input type="checkbox"/> ADFS	Two extra DIN slots in front shelf - can be fitted with card or drawer available as an accessory
<input type="checkbox"/> PTR-FH	Gearbox driven high speed PTO with SAE drive flange	<input checked="" type="checkbox"/> BUPALARM	Reverse alarm
<input type="checkbox"/> PTR-FL	Gearbox driven low speed PTO with SAE drive flange		
<input type="checkbox"/> PTRD-D	Gearbox driven HIGH SPEED PTO for two plug-in hydraulic pumps		

Standard Equipment

Optional Equipment

For more detailed information about cab and powertrain equipment, please refer to separate specification sheets.

For all possible options and combinations of options please consult your Volvo sales contact who can create a specification to match your requirements using the Volvo Sales Support system (VSS).

The factory reserves the right to modify design and change equipment without previous notification. The specification can vary from country to country.

MODEL RANGE

FH 16 8x2 Rigid - Pusher & Tag Tridem – contact sales engineering reference

<input type="checkbox"/> RTOLL-PK	Road toll PREPARATION kit for trucks operating with "Toll Collect" in Germany	<input type="checkbox"/> PH-CAB2	Cab parking heater -1.8kW Air to air
<input type="checkbox"/> LOADIND	Load indicator with central dashboard display	<input type="checkbox"/> PH-ENGCA	Cab parking heater - Engine and cab
<input type="checkbox"/> REMC-MF	Multi-functio wireless remote control	<input type="checkbox"/> SLCP-BAS	Sleeper control panel - Basic with switches for interior light, night heater, roof hatch and door lock
<input type="checkbox"/> FIREXT3S	Fire extinguisher - 3kg mounted on the seat base	<input type="checkbox"/> SLCP-LUX	Sleeper control panel - Luxury with switches for interior light, night heater, roof hatch, door lock, alarm clock, window and radio
<input type="checkbox"/> WARNVEST	High visibility warning vest - no sleeves	<input type="checkbox"/> SAFE	Driver's safe box - for personal items
<input type="checkbox"/> AIDKIT	First aid kit - Legal demand for EU markets including delivery to EU bodybuilder	<input type="checkbox"/> RUS-BAS	Rear cab upper storage - 300 mm high
<input type="checkbox"/> AIDKIT1B	First aid kit - Legal demand for trucks transiting Germany	<input type="checkbox"/> RUS-HIG	Rear cab upper storage - 440 mm high - volume 245 litres
<input type="checkbox"/> WARNLAMP	Portable warning lamp	<input type="checkbox"/> TABLE	Bunk table - Folding and height adjustable fitted on lower bunk
<input type="checkbox"/> LAMP-IN	Inspection lamp	<input type="checkbox"/> REFR-RUS	Fridge - 28 litre rear upper wall mounted with dividers
<input type="checkbox"/> BULBKIT	Bulb and fuse kit	<input type="checkbox"/> REFRIG	Fridge - 33 litre under-bunk mounted with freezer dividers
<input checked="" type="checkbox"/> WRITEPAD	Writing pad	<input type="checkbox"/> MICRO-PK	Microwave equipment - Wiring preparation kit for oven
<input checked="" type="checkbox"/> DST-CF4	Driver seat - Suspended, adjustable shock absorber, travel, backrest & lumbar controls with integrated seatbelt	<input type="checkbox"/> BOTH-D	Bottle holder - One under dashboard centre section
<input type="checkbox"/> DST-CF5	Driver seat - Suspended with adjustable shock absorber, travel, backrest, lumbar & heat controls with integrated seatbelt	<input type="checkbox"/> BOTH-DL	Bottle holders - Two. One under dashboard centre section and one mounted to the under bunk drawer
<input type="checkbox"/> DST-CF6	Driver seat - Suspended with adjustable shock absorber, travel, backrest, lumbar, heat and ventilation controls with integrated seatbelt	<input type="checkbox"/> BOTH-L	Bottle holder - One mounted to the under bunk drawer
<input type="checkbox"/> DST-LUX1	Driver seat - Deluxe 1: electrical adjustment with memory function, lumbar support, heating & ventilation with integrated seatbelt	<input type="checkbox"/> COFMA-PK	Coffee maker - Preparation kit.
<input type="checkbox"/> DST-LUX2	Driver seat - Deluxe 2: electrical adjustment with memory function, lumbar support & heating with integrated seatbelt	<input type="checkbox"/> INLI-BAS	Interior light - White LEDs
<input type="checkbox"/> SBD-RED	Seat belt colour - Red	<input type="checkbox"/> INLI-NL	Interior light - White and red nightlight LEDs without dimmer
<input type="checkbox"/> SBPRE-DS	Driver seat belt pretensioner	<input checked="" type="checkbox"/> INLI-NLD	Interior light - White and red nightlight LEDs with dimmer
<input type="checkbox"/> PST-BAS1	Passenger seat - Fixed non suspended fold up with seatbelt mounted on cab "B" post	<input type="checkbox"/> ARL-FLEX	Flexible reading lamps - Two "snake" type
<input type="checkbox"/> PST-CF4	Passenger seat - Suspended, adjustable shock absorber, travel, backrest & lumbar controls with integrated seatbelt	<input checked="" type="checkbox"/> RH-EE	Fixed tinted glass sky window with emergency exit
<input type="checkbox"/> PST-CF5	Passenger seat - Suspended with adjustable shock absorber, travel, backrest, lumbar & heat controls with integrated seatbelt	<input type="checkbox"/> RH-ER	Steel roof hatch - Electrically operated, rear opening with emergency exit
<input type="checkbox"/> PST-RX1	Passenger seat - Fixed non suspended, features: 90-degree rotation and tilt function with seatbelt mounted on cab "B" post	<input type="checkbox"/> RH-ETR	Tinted glass roof hatch - Electrically operated, rear opening with emergency exit
<input type="checkbox"/> PST-STD2	Passenger seat - Fixed with backrest adjustment, non suspended with seatbelt mounted on cab "B" post	<input type="checkbox"/> RH-MTR	Tinted glass roof hatch - Manually operated, rear opening with emergency exit
<input checked="" type="checkbox"/> PST-STD4	Passenger seat - Standard suspended with seatbelt mounted on cab "B" post	<input checked="" type="checkbox"/> GLAS-TIN	Cab windows - Tinted
<input type="checkbox"/> SBPRE-PS	Passenger seat belt pretensioner	<input type="checkbox"/> SWIND-BS	Cab side window - On both sides behind 'B' post
<input checked="" type="checkbox"/> ARMRE-BB	Armrests - Two on both driver & passenger seats	<input checked="" type="checkbox"/> VANMIR	Vanity mirror - In front shelf
<input checked="" type="checkbox"/> ARU-LEA	Armrest upholstery - Leather	<input type="checkbox"/> AS-FUS	Extra shelf in front compartments
<input checked="" type="checkbox"/> GRABHI-L	Instep cab grab handle - Leather finish	<input type="checkbox"/> INFOT-PK	TV mounting preparation kit - Above the driver's door, includes bracket, electrical and speaker connections
<input type="checkbox"/> FMAT-RUB	Footwell floor mats - Rubber	CAB EXTERIOR	
<input checked="" type="checkbox"/> FMAT-TX2	Footwell floor mats - Two sets, Rubber and textile with an embossed pile supplied in the cab	<input type="checkbox"/> EXTL-BAS	Basic exterior finish - Satin Volvo badges, grey grille, instep, bumper, bumper spoiler, grille, door handles mirror housing and sunvisor if specified.
<input checked="" type="checkbox"/> LBK80F	Lower bunk - Fixed with wide middle section 815 in the centre x 2000 mm	<input checked="" type="checkbox"/> EXTL-EN3	Enhanced exterior finish - Waterfall Grille. Chrome Volvo badges and door handles. Instep, bumper and bumper spoiler in cab colour if specified. Aluminium step inserts. Mirror housing and sun visor if specified with silver accents.
<input type="checkbox"/> LBK80FRE	Lower bunk - Electrically operated recliner with wide middle section 815 in the centre x 2000 mm	<input checked="" type="checkbox"/> DGLAS-H	Door glass - Hardened
<input type="checkbox"/> LBK80FRM	Lower bunk - Manually operated recliner with wide middle section 815 in the centre x 2000 mm	<input type="checkbox"/> DGLAS-L	Door glass - Laminated
<input type="checkbox"/> MATL-FI	Lower mattress - Firm pocket sprung	<input checked="" type="checkbox"/> LOCK-REM	Door locks - Remote central locking
<input type="checkbox"/> MATL-FI4	Lower mattress - Firm, memory foam, 2000x700x130 mm	<input checked="" type="checkbox"/> BUMP-B	Front bumper - Plastic
<input checked="" type="checkbox"/> MATL-SF	Lower mattress - Flexi-zone semi-firm, pocket springs up to 100kg - 16 stone	<input checked="" type="checkbox"/> BUMP-B2	Front bumper - Steel
<input type="checkbox"/> OLMAT-BA	Mattress overlay protector - 35mm thick	<input type="checkbox"/> BUMP-HD	Front bumper - Heavy duty - FMX
<input checked="" type="checkbox"/> OLMAT-PR	Mattress overlay protector - Premium 50mm thick	<input type="checkbox"/> BUMP-SP	Front bumper spoiler
<input type="checkbox"/> TBK60AD	Top bunk - Height adjustable foldable 600 x 1900mm	<input type="checkbox"/> GUARD-EH	Sump and radiator guard - to protect engine and hoses
<input type="checkbox"/> TBK60F	Top bunk - Fixed foldable 600 x 1900mm	<input checked="" type="checkbox"/> BUGNET	Radiator insect screen
<input type="checkbox"/> TBK70AD	Top bunk - Height adjustable foldable 700 x 1900mm	<input type="checkbox"/> CTILTP-E	Electrically operated hydraulic cab tilt
<input type="checkbox"/> TBK70F	Top bunk - Fixed foldable 700 x 1900mm	<input checked="" type="checkbox"/> CTILTP-M	Manually operated hydraulic cab tilt
		<input type="checkbox"/> FCABS-A	Front cab suspension - Air
		<input checked="" type="checkbox"/> FCABS-M	Front cab suspension - Mechanical spring
		<input type="checkbox"/> RCABS-A	Rear cab suspension - Air
		<input checked="" type="checkbox"/> RCABS-M	Rear cab suspension - Mechanical spring

Standard Equipment

Optional Equipment

For more detailed information about cab and powertrain equipment, please refer to separate specification sheets.

For all possible options and combinations of options please consult your Volvo sales contact who can create a specification to match your requirements using the Volvo Sales Support system (VSS).

The factory reserves the right to modify design and change equipment without previous notification. The specification can vary from country to country.

MODEL RANGE

FH 16 8x2 Rigid - Pusher & Tag Tridem – contact sales engineering reference

■ HCC-INEX	Exterior hood lock - Activated by door lock remote	□ WLC-H2W	Two H3/70W white working lamps high mounted on the back of cab
□ MIRCFPCS	Mirrors - Electrically heated and operated main and wide-angle with manually adjusted kerb view mirror on the passenger side and position camera in nearside mirror arm.	□ WLC-PKCH	Working lamp back of cab - Preparation kit - cables and switch
■ MIRCOMF	Electrically heated and operated main and wide angle mirrors and manually adjusted kerb view mirror on passenger side	□ WLC-PKH	Preparation kit, cables and switch for high mounted working lamps back of cab
■ AMIR-F20	Auxiliary front view mirror with a 200mm radius	□ WLC-PKL	Preparation kit, cables and switch for low mounted working lamps back of cab
□ SUNV-H	External smoke grey sunvisor	□ WLC-PKLH	Preparation kit - cables and switch for low and high mounted working lamps back of cab.
□ AD-ROOF	Cab roof deflector - Adjustable	■ ECBB-HIG	Body builder electrical centre with body builder module
□ AD-SIDES	Cab side deflector - Short extension panels	□ ECBB-MED	
■ HL-BASIC	Headlamps - Halogen	□ BBCHAS1	One 7-pole connector for Body builder interface
□ HL-CLEAN	Head lamp cleaner - washer jets	□ BBCHAS3	Three 7-pole connectors for Body builder interface
□ HLP-ST	Headlamp protection	□ BEPR-T2	Body builder electrical software preparation for tipper with remote control
□ HL-ADJ	Headlight adjustment - Switch in cab	□ EXSTER	External steering control - Volvo dynamic steering and bodybuilder module prepared for external control system, installed and computer by bodybuilder
□ DRIVL2	Two spot lamps	■ TD-LED	Trailer detection with LED sensing
□ UDRIVL	Auxiliary driving lights - Without	□ FRFS-BS	Frame rail free space - both sides to give space for crane legs or other equipment.
■ FOGL-WC	Front fog lights	□ FBA-BTF	Lower front body attachments for torsionally flexible - platform body
□ CL-STAT	Static corner lights	□ FBA-BTSF	Lower front body attachments for torsionally semi-flexible body - box or curtainsider
□ ASL-RF2	Two Hella H11 70W spotlamps in Globetrotter sign box	□ HBA-FSFB	Holes for body attachments - flexible/semi-flexible body
□ BEACOA2F	Roof beacons - Two front roof mounted amber LED	□ HBA-SB	Holes for body attachments - stiff body
□ BEACOA2R	Roof beacons - Two rear roof mounted amber LED	□ RBA-T2	Lower rear body attachments for helper frame
□ BEACON-P	Roof beacons - switch and wiring preparation only	□ CRANEPK1	Crane plates mounted to frame, for cranes up to 10 tonne metre capacity
□ BEACONA4	Roof beacons - Four amber LED - two front/ two rear	□ CRANEPK2	Crane plates mounted to frame, for cranes up to 20 tonne metre capacity
□ CABPT-R1	Single outlet for roof mounted accessories	□ CRANEPK4	Crane plates mounted to frame, for cranes up to 40 tonne metre capacity
■ CABPT-R2	Twin outlets for roof mounted accessories.	□ AUXL-SPK	Electrical preparation kit - wiring and switch for snow plough lights
□ SPOTP-F	Spotlamp preparation in front, max 280W	□ TAILPRE2	Tail lift preparation kit, wireless remote operation
□ SPOTP-R	Spotlamp preparation on roof, max 280W	□ TAILPREP	Taillift preparation kit - cab switch and warning in driver display
□ SPOTP-RF	Spotlamp preparation on cab roof and in cab front, max 2x280W	□ AESW2	Two Body builder bistable electrical switches (marked AUX1 / AUX2)
□ ROS-IL2	Preparation kit for illuminated roof sign with switch loose in cab, fit after registration	□ AESW2PK	2 Body builder bistable el.switches (marked AUX1/AUX2) and prep. for 4 more switches
□ CSGN-ENG	Engine size and power headboard logo	□ AUXSW-4	Wiring for 4 extra switches (from Body builder electrical centre to switch positions)
□ CSGN-GTR	"Globetrotter" headboard logo	DELIVERY SERVICES	
■ HORN-F1S	Horn - Air single tone - chassis mounted	■ TGW-4GWL	Telematics gateway - GSM/GPRS/4G modem, LTE & WLAN
□ HORN-R2S	Horn - Air - Two roof-mounted	□ FMS-PK	Fleet Management System gateway - required for aftermarket telematics
□ ANT-CBR	Roof mounted antenna for CB radio, single aerial. Only Globetrotter cabs brings in extra DIN slots.	□ DRUT1	Driver utility app - "My Truck" - 1 year subscription For mobile phone, tablet, with android and IOS systems. Only available with Volvo Connect subscription
□ ACCB-R-AP	Front, middle & rear roof mounted accessory brackets	□ DRUT2	Driver utility app - "My Truck" - 2 year subscription For mobile phone, tablet, with android and IOS systems. Only available with Volvo Connect subscription
□ ACCB-R-F	Front roof mounted accessory bracket	□ DRUT3	Driver utility app - "My Truck" - 3 year subscription For mobile phone, tablet, with android and IOS systems. Only available with Volvo Connect subscription
□ ACCB-R-FM	Front & middle roof mounted accessory brackets	□ DRUT4	Driver utility app - "My Truck" - 4 year subscription For mobile phone, tablet, with android and IOS systems. Only available with Volvo Connect subscription
□ ACCB-R-FR	Front & rear roof mounted accessory brackets	□ DRUT5	Driver utility app - "My Truck" - 5 year subscription For mobile phone, tablet, with android and IOS systems. Only available with Volvo Connect subscription
□ ACCB-R-M	Middle roof mounted accessory bracket		
□ ACCB-R-R	Rear roof mounted accessory bracket		
□ ACCB-R-RM	Rear & middle roof mounted accessory brackets		
□ STUC-B	Left and right storage compartments under cab		
□ STUC-L	Left storage compartment under cab		
□ STUC-R	Right storage compartment under cab		
□ REFS-TW	White cab conspicuity markings by packed in cab		
□ REFS-TY	Yellow cab conspicuity markings by packed in cab		
SUPERSTRUCTURE PREPARATIONS			
□ SRWL-PK	Chassis-mounted working lamps - Side work and reverse lamp preparation and 3 position switch - Max load 280W		
□ SWL-2FW	Chassis-mounted working lamps - Two white front-mounted LED lamps		
□ SWL-2RW	Chassis-mounted working lamps - Two white rear-mounted LED lamps		
□ SWL-4W	Chassis-mounted working lamps - Four white front and rear-mounted LED lamps		
□ SWL-PK	Chassis-mounted working lamps - Side work lamp preparation and 2 position switch - Max load 280W		

■ Standard Equipment

□ Optional Equipment

For more detailed information about cab and powertrain equipment, please refer to separate specification sheets.

For all possible options and combinations of options please consult your Volvo sales contact who can create a specification to match your requirements using the Volvo Sales Support system (VSS).

The factory reserves the right to modify design and change equipment without previous notification. The specification can vary from country to country.

MODEL RANGE

FH 16 8x2 Rigid - Pusher & Tag Tridem – contact sales engineering reference

Volvo Trucks. Driving Progress