

MODEL RANGE

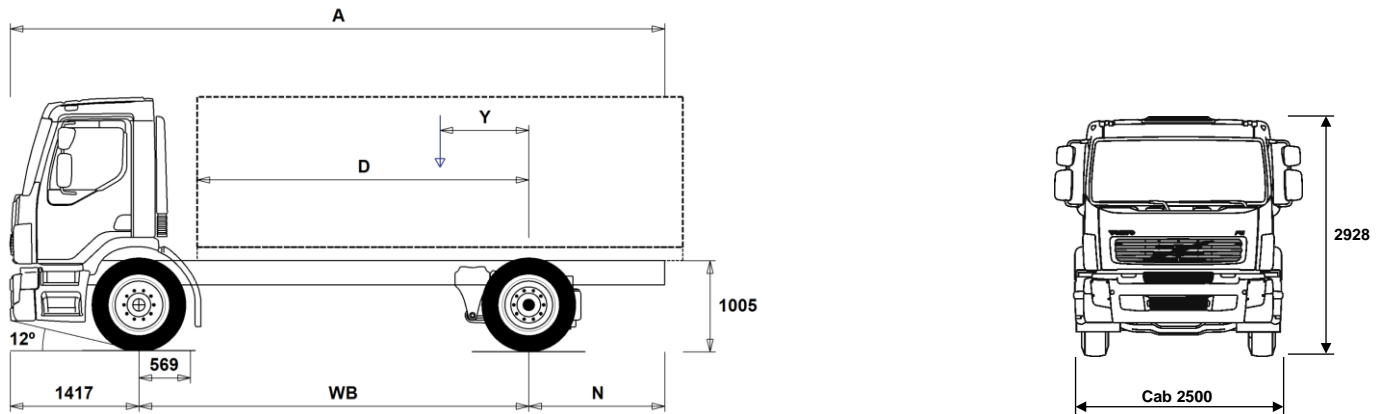

Volvo Trucks. Driving Progress

FE 4x2 Platform - Rear Air Suspension FES42 R HCM



Chassis Dimensions [mm]

WB Wheelbase	3500	3700	3900	4100	4300	4500	4750	5000	5250	5500	5800	6100	6450
A Overall Chassis Length	6607	6907	7257	7557	7907	8207	8607	9007	9407	9807	10307	10757	11307
D Center of rear axle to front of body	2857	3057	3257	3457	3657	3857	4107	4357	4607	4857	5157	5457	5807
N Rear Overhang (Min.)	1200	1200	1200	1200	1200	1200				2005	2240		
N Rear Overhang (Max.)	1690	1790	1940	2040	2190	2290	2440	2590	2740	2890	3090	3240	3440
Y Center of Gravity for Payload (Min.)	809	856	905	952	986	1026	1076	1130	1200	1259	1332	1399	1422
Y Center of Gravity for Payload (Max.)	978	1034	1094	1150	1193	1244	1307	1373	1455	1526	1614	1697	1743

Chassis Weights [kg]

Front Axle	3625	3625	3615	3615	3645	3675	3705	3710	3675	3675	3670	3680	3840
Rear Axle	1930	1940	1960	1960	1900	1935	1955	1945	1975	1985	1995	2020	2090
Kerb Weight	5555	5565	5575	5575	5545	5610	5660	5655	5650	5660	5665	5700	5930
Payload (including body, driver, fuel, etc.)	12445	12435	12425	12425	12455	12390	12340	12345	12350	12340	12335	12300	12070

Turning Diameter [mm]

Turning Circle Diameter Kerb to Kerb	12800	13400	14100	14700	15300	15900	16700	17400	18200	19000	19900	20800	21900
Turning Circle Diameter Wall to Wall	14200	14800	15500	16100	16700	17300	18100	18900	19600	20400	21300	22300	23300

Plated Weights [kg]

	Plated	Design
Gross Vehicle Weight	18000	18000
Gross Combination Weight	40000	
Front Axle	7100	7100
Rear Axle	11500	13000

Important Notes

Chassis Dimensions

Cab Height: +3 mm for L2H1.
 Front Axle to Back of Cab: +200 mm for L2H1, +366 mm for L3H1.
 D-measure includes a front clearance of 74 mm and for rigid trucks also a subframe of 120 mm.
 Height can vary ± 20 mm for leaf and ± 10 mm for air suspension.
 All dimensions are for unladen chassis and any tag axles down. Chassis height used: CHH-STD.

Weight and dimensions are based upon the following tyres:
 Front Axle Tyres: 295/80R22.5
 Drive Axle Tyres: 295/80R22.5

Chassis weight includes oil, water, AdBlue, 70 litres fuel and without driver.
 Kerb weight can vary $\pm 1.5\%$.

Turning diameters are theoretically calculated.

Legal weights can differ from country to country.

For more detailed weight information, including optional equipment weights, ask your Volvo sales contact to enter your specification into the Volvo Weight Information system (WIS).

Do NOT use this drawing for bodybuilding. Refer to Volvo Bodybuilder Instructions and chassis assembly drawing 20824877, 20824876, 20824879.

MODEL RANGE

FE 4x2 Platform - Rear Air Suspension FES42 R HCM

CORE COMPONENTS

- TOWF-N1B** One front towing device, two towing positions
- TOWF-NO1** One front towing device
- CHH-MED** Chassis height medium - For a specific loading height always check the unique BEP chassis drawing
- CHH-STD** Standard chassis frame height above ground
- L1H1** Short day cab - with steel safety cage design
Designed and built to Swedish impact and ECE R29 regulations
- L2H1** Medium cab - with steel safety cage design
Designed and built to Swedish impact and ECE R29 regulations
- L3H1** Sleeper cab - with steel safety cage design
Designed and built to Swedish impact and ECE R29 regulations
- EU3** Euro 3 Engine emission control.
- EU4SCR** Euro 4 Selective Catalytic Reduction (SCR) engine emission control.
- EU5EEV** Euro 5 EEV Enhanced Environmental Vehicle
- EU5SCR-M** Euro 5 Mandatory engine emission level.
- D7E240** D7E240 7.2l engine developing 240hp
Max torque 920Nm at 1200-1700rpm.
- D7E280** D7E280 7.2l engine developing 280hp
Max torque 1050Nm at 1200-1700rpm.
- D7E320** D7E320 7.2l engine developing 320hp
Max torque 1200Nm at 1200-1700rpm.
- D7F240** D7F240 7.2l engine developing 240hp
Max torque 940Nm at 1200-1800rpm.
- D7F260** D7F260 7.2l engine developing 260hp
Max torque 1010Nm at 1200-1800rpm.
- D7F300** D7F300 7.2l engine developing 300hp
Max torque 1160Nm at 1200-1800rpm.
- D7F340** D7F340 7.2l engine developing 340hp
Max torque 1300Nm at 1200-1900rpm.
- EBR-CBJ3** Engine brake producing 188kW at 2800rpm
controlled by steering column switch
- EBR-EPG** Exhaust brake producing 130kW at 2800rpm
controlled by steering column switch
- AL306** Allison AL306 6-speed automatic gearbox
(If a PTO is required it must specified from the factory)
- STO1309** STO1309 9-speed range change overdrive gearbox
- ZTO1006** ZTO1006 6-speed overdrive gearbox
- ZTO1109** ZTO1109 9-speed range change overdrive gearbox
- CS39A-O** Single plate 395mm (16") clutch
- CS43B-O** Single plate 430mm (17") clutch
- FAL7.1** Front axle design capacity 7.1 tonnes
- FAL7.5** Front axle design capacity 7.5 tonnes
- FAL8.0** Front axle design capacity 8.0 tonnes
- FST-AIR** Front suspension type, air
- FST-PAR** Parabolic front springs
- RAD-A2R** Two bag rear air suspension
- RS1370HV** RS1370HV hub reduction 13tonne drive axle with differential lock
- RSS1344C** RS1344C single reduction rear axle - design GCW 44tonne
with differential lock
- RAL13** Rear axle design capacity 13 tonnes
- RST-AIR** Rear air suspension
- RSTAB1** Rear anti-roll bar
- UBOGLIFT** Without tag axle lift

Packages

- AUDIODAB**
- AUDIOPD**

TRUCK USE

- ADR2** ADR package for transportation of dangerous goods on road

- Standard Equipment
- Optional Equipment

For more detailed information about cab and powertrain equipment, please refer to separate specification sheets.

For all possible options and combinations of options please consult your Volvo sales contact who can create a specification to match your requirements using the Volvo Sales Support system (VSS).

The factory reserves the right to modify design and change equipment without previous notification.
The specification can vary from country to country.

(Note does NOT include safe loading pass package if required this is quoted separately)

- STWPOS-L** Left hand drive
- STWPOS-R** Right hand drive

CHASSIS

- BRAKE-DV** Ventilated disc brakes
- EBS-HIG** EBS high package including traction control, hill hold and ESP
Electronic stability program - ESP only works on solo rigids.
EBS+ package including traction control & hill hold
EBS standard package without traction control
- EBS-MED**
- EBS-STD**
- SUSPL-E2** Integral dash switches for air suspension leveling control
- FRAME77** Frame thickness 7mm
- FRAME88** Frame thickness 8mm
- FRAMEHIG** Frame section height 300mm
- FRAMELOW** Frame section height 266mm
- FRACLOS** With frame closing
- 2BATT170** 2 x 170 Ah capacity batteries on left hand side
- 2BATT225** 2 x 225 Ah capacity batteries on left hand side
- EXD-LEFT** Horizontal silencer - catalyst, with left exhaust outlet
- EXD-REAR** Horizontal silencer - catalyst, with rear exhaust outlet
- EXD-VERL** Horizontal silencer - catalyst, with vertical exhaust outlet
- R315A56** 315litre right hand aluminium 560 mm D-shaped fuel tank
Min volume 215l
Max volume 830l
- UL-FUEL** Without left fuel tank
Min volume 160l
Max volume 315l
- XTL315AL** Left extra fuel aluminium tank, 315 litre
- FUFF-ATS** Fuel filling anti-syphon device
- ATANK-AL** Aluminium air tanks
- ADTR70** 70 litre plastic AdBlue tank on right hand side
- ADTL70** 70 litre plastic AdBlue tank on left hand side
- SWCP-LF** Spare wheel carrier on left side, in front of rear axle.
- SWCP-R** Spare wheel carrier rear mounted below frame.
- SWCP-T** Spare wheel supplied temporarily strapped to chassis
- SWCP-TP** Spare wheel transport mounted on frame, (spare wheel carrier not included)
- WHC-FIX1** One wheel chock
- WHC-FIX2** Two wheel chocks
- TB-L33** Toolbox 330 x 330 mm on the left side
- TB-L75** Toolbox 754 mm on the left side
- TOWMBRH** Towing member, high position, mounted in centre of frame
- C-RI5055** Towing coupling, Ringfeder 5055 G-150
- C-RO400G** Towing coupling, Rockinger 400 G-150
- C-RO40AG** Towing coupling, Rockinger 400 G-145
- C-RO430G** Towing coupling, Rockinger 430 G-150
- C-RO43AG** Towing coupling, Rockinger 430 G-145
- C-RO50**
- TOWR-ONE** Towing hitch attached to rear crossmember
- RUP-FIX2** Fixed rear EC approved aluminium underrun
- RFEND-B** Three piece rear mudwings
- RFEND-T** Mudwings on drive axle for transportation only

WHEELS & TYRES

- RT-ALP**
- RT-STEEL** Steel rims on all axles
- SPWT-F** Spare wheel & tyre with front tyre pattern

DRIVELINE EQUIPMENT

- RET-TPT** Retarder for automatic gearbox

MODEL RANGE

FE 4x2 Platform - Rear Air Suspension FES42 R HCM

- ACL1ST-S** Air filter with secondary filter element
 - ENGENV1** Engine working environment -40° to +40°C
 - ENGENV2** Engine working environment -15° to +40°C
 - ENGENV3** Engine working environment -25° to +40°C
 - COOLC40** Cooling capacity 40° C
 - COOLC48** Cooling capacity 48° C
 - AF-E** Auxiliary fuel filter, electrically heated
 - EST-AID** Engine start preheating element
 - STHLP** Start help
 - ETC** Electronic throttle control - dash mounted switches that control PTO speed
 - 220EBH08** Engine block heater, 220V/0.8kW
 - FLAMEPR** Flame protection in the exhaust system
 - PTER-DIN** Rear engine mounted PTO with DIN5462 (female) splined shaft for a close coupled pump
 - PR-HP4T** Live-drive PTO for Allison gearbox output 400Nm for hydraulic pump connection mounted on top of the torque converter
 - PR-HP4TL** Live-drive low speed PTO for Allison gearbox output 400Nm for hydraulic pump connection mounted on top of the torque converter
 - PR-HP6T** Live-drive PTO for Allison gearbox output 600Nm for hydraulic pump connection mounted on top of the torque converter
 - PR-HP6TH** Live-drive high speed PTO for Allison gearbox output 600Nm for hydraulic pump connection mounted on top of the torque converter
 - PR-HP6TL** Live-drive low speed PTO for Allison gearbox output 600Nm for hydraulic pump connection mounted on top of the torque converter
 - PTR-FH1** Rear PTO Gearbox S81 flange DIN connection
 - PTR-FH2** Rear PTO Gearbox S84 flange DIN connection
 - PTR-FH5** Rear PTO Gearbox S88 flange DIN connection
 - PTR-PH1** Rear PTO Gearbox S81 pump DIN connection
 - PTR-PH2** Rear PTO Gearbox S84 pump DIN connection
 - PTR-PH4** Rear PTO Gearbox S88 pump DIN connection
 - PTR-PK** Electrical and solenoid prep kit for gearbox PTO
 - PTR-ZF2** Rear Power Take Off flange DIN connection
 - PTR-ZF3** Rear Power Take Off Gearbox pump DIN connection
 - PTR-ZF4** Rear PTO Gearbox 320Nm flange connection
 - PTR-ZF5** Rear PTO Gearbox 320Nm pump connection
 - PTRA-PH2** Add PTO for 9sp box twin S84 pump conn
 - HPG-F101** Gearbox mounted hydraulic pump F1-101, fixed displacement, single flow.
 - HPG-F41** Gearbox mounted hydraulic pump F1-41, fixed displacement, single flow.
 - HPG-F51** Gearbox mounted hydraulic pump F1-51, fixed displacement, single flow.
 - HPG-F61** Gearbox mounted hydraulic pump F1-61, fixed displacement, single flow.
 - HPG-F81** Gearbox mounted hydraulic pump F1-81, fixed displacement, single flow.
 - ENGPROT** Engine protection
- CAB INTERIOR**
- DST-CF5** Driver seat comfort air suspended, heated, with seatbelt built into the seat and adjustments for the following , backrest tilt, height, front tilt, length, adjustable shock absorber and rapid descent.
 - DST-ECO A**
 - DST-STD2**
 - DST-STD8**
 - PST-BAS1**
 - PST-ECO A**
 - PST-STD6**
 - PST-STD7**
- APST** Additional passenger seat.
 - ARMRE-PS** Single armrest on passenger seat next to the driver.
 - BED2058** Occasional single piece foam bunk
Bunk size - Thickness 13.5mm x Width 58cm x Length 200cm
Smoke detector
Front and side window curtains
 - BED2078** Fixed sprung bunk
Bunk size - Thickness 13.5mm x Width 78cm x Length 200cm
Smoke detector
Front and side window curtains, with additional bunk curtain
 - REST2078** Two piece fold up foam bunk
Bunk size - Thickness 9mm x Width 78cm x Length 200cm
Smoke detector
Front and side window curtains
 - BEDBAR** Bunk protection bar
 - ETS-FL** Engine tunnel storebox, adjustable on engine tunnel, features large drawer, bottle holder, pullout table and 12/24v electric sockets.
 - ETS-FLRH** Engine tunnel storebox, adjustable on engine tunnel, features large drawer, bottle holder, lifting top, pullout table and 12/24v electric sockets.
 - ETS-FMR** Engine tunnel storebox, fixed, features two large boxes, rear one with lift of lid, front one with folding flap too form table, front oddments tray and 24v electric socket.
 - BUNKBOX** Removable open storage bin behind seats
 - FOHS-BAS** Front overhead open storage pockets with nets
 - FOHS-COV** Front overhead storage lockers with doors
 - REF-IC28** Fridge 28litre mounted on engine tunnel
 - RWCLOH-H** Clothes rail on rear wall
 - CU-HEAT** Conventional heater unit
 - CU-MCC** Manually operated air conditioning
 - PH-CAB** 1.8kW Air to air night heater
 - RH1ELEG** Roof hatch - glass, electrically operated.
 - RH1ELEP** Roof hatch - electrically operated.
 - RH1MANP** Roof hatch - manually operated.
 - URHATCH** Roof hatch - not fitted.
 - WIND-HF** Heated windscreen
 - AWIND-RF** Rear window without curtains.
 - SWIND-BS** Side windows in rear cab panels both sides
 - SWIND-PS** Side rear nearside passenger window
 - AWIND-DP** Lower kerb window on passenger door
 - WLIFT-EB** Electric windows both sides
 - WLIFT-ME** Mechanical window lift
 - LOCK-ALL** Central locking with remote control and remote electronic battery master switch.
Note there is no manual master switch on the chassis
Manual locking driver and passenger doors.
Central door locking with remote control
 - LOCK-MAN**
 - LOCK-REM**
 - IL-DOOR** White step light in lower door
 - HLA-EL** Electrically adjustable headlights
 - HLA-MEC** Mechanically adjustable headlights
 - ISUNV-S** Internal side sunvisor
 - CURT-WB** Front & side window curtains, with curtain between bunk and seat.
Note these do not cover the lower door or rear window if specified.
 - CURT-WIN** Front & side window curtains only.
Note these do not cover the lower door or rear window if specified.
 - CBM-RSH** Aerial connection for CB radio supplied in front overhead shelf
 - ACON-USB** Audio USB connector

Standard Equipment

Optional Equipment

For more detailed information about cab and powertrain equipment, please refer to separate specification sheets.

For all possible options and combinations of options please consult your Volvo sales contact who can create a specification to match your requirements using the Volvo Sales Support system (VSS).

The factory reserves the right to modify design and change equipment without previous notification. The specification can vary from country to country.

MODEL RANGE

FE 4x2 Platform - Rear Air Suspension FES42 R HCM

- **XCON-AUD** 3.5mm audio mini jack socket
 - **AIP-BT** Bluetooth phone capability
 - **INST-BAS** Basic instruments & concise driver's information display
Includes - Speedometer, Rev counter, single air pressure & fuel level gauges
 - **INST-MED** Medium instruments & driver's information display
Includes - Speedometer & Rev counter
Gauges for fuel level, Oil pressure, Turbo boost, Coolant temperature & individual front and rear air circuits
 - **FMS** Fleet Management System gateway
 - **DOL12S12** 12 volt dash single outlet
 - **DOL24+12**
 - **IMMOAL** Immobiliser and cab alarm
 - **IMMOUAL** Immobiliser
 - **BUPALARM** Reverse alarm
 - **REM-AUD** Remote control for audio system
 - **FIRE2SWE** 2kg fire extinguisher located by the driver's seat next to the door
 - **WARNVEST** High visibility warning vest - no sleeves
 - **WARNTRI1** One warning triangle
 - **WARNTRI2** Two warning triangles
 - **WARNTRI3** Three warning triangles
 - **AIDKIT** First aid kit - Legal demand for EU markets including delivery to EU bodybuilder
 - **TACHOP2** Continental VDO DTCO 2.0 digital tachograph for ADR applications can be modified for remote download
 - **TACHOP4** Continental VDO DTCO 2.0 digital tachograph can be modified for remote download
 - **CRUISEC** Cruise control with switches in the steering wheel
 - **JACK-10T** 10 tonne bottle jack
 - **INFLAHOS** Tyre inflation hose
 - **GAUGE-TP** Tyre pressure gauge
 - **MAT-RUB** Rubber Mats
 - **XINS-CAB** Extra insulation in cab
 - **XINS-MCA** Extra insulation medium level in cab
 - **WRITEPAD** Writing pad
- ### CAB EXTERIOR
- **CTILT-P-E** Electrically operated hydraulic cab tilt
 - **CTILT-P-M** Manually operated hydraulic cab tilt
 - **CABS-FUA** Rear cab suspension - Air
 - **CABS-MEC** Rear cab suspension - coil spring
 - **MIRCOMF** Electrically heated and operated main mirrors with wide angle mirror on both sides and kerb mirror on the passenger side.
 - **MIRSTD** Electrically heated main mirrors with wide angle mirror on both sides and kerb mirror on the passenger side.
 - **CMIR-FF** Close view front mirror
 - **SUNV-URL** Exterior sunvisor
 - **AD-ROOF** Fixed cab roof air deflector - not adjustable
 - **AD-ROOFA** Adjustable air deflector
 - **AD-SIDES** Cab side air deflector, short extension panels.
 - **HL-CLEAN** Head lamp cleaner jet
 - **HL-ASYML** Head lamp asymmetric, right hand drive
 - **HL-ASYMR** Head lamp asymmetric, left hand drive
 - **LOWB-DAY** Day running light
 - **LOWB-STD** Standard low beam
 - **FOGL-WB** Fog lights located in the corner of the front bumper

- **BEACON-P** Beacon preparation
- **BEACONA2** Two amber beacons directly mounted to cab roof
- **AHORN-D** Twin roof mounted air horns
- **ACCBR-PK** Accessory roof bracket - preparation kit
- **ACCBRKTF** Accessory roof bracket - front

SUPERSTRUCTURE PREPARATIONS

- **CRANE-PK** Crane preparation kit - mounting plates for subframe behind cab
Maximum crane capacity 20tonne/m
- **TBC-EC** EEC palm air connections
- **TRBR-UPT** Trailer brake control, without pressure trailer control
- **TRBRAKE1** Trailer brake, 1 valve
- **BBP-CF** Body Builder preparation, wiring pass through in cab floor
- **ELCE-CK** Electrical interface for Body Builder
- **ELCE-PK1** Electrical preparation kit for Body Builder does not include bodybuilder module
- **TAILPREP** Taillift preparation kit - cab switch and warning in driver display
- **BODATTF** Lower flexible front body mounts fixed to chassis - upper not supplied
- **BODATTS** Pre-punched holes for TANKER flexible body attachments - mountings not supplied.
- **BODATTSF** Body attachments, semi-flexible
- **UBODATT** Without body attachments - punched holes

DELIVERY SERVICES

- **LAMP-IN** Inspection lamp

VOLVO

Volvo Truck Corporation

volvotrucks.com