



# ATTACHMENTS



DURABLE AND RELIABLE

WHERE EXPERIENCE COUNTS

# FRD COMPACTOR

## EXCAVATOR - FCP SERIES -

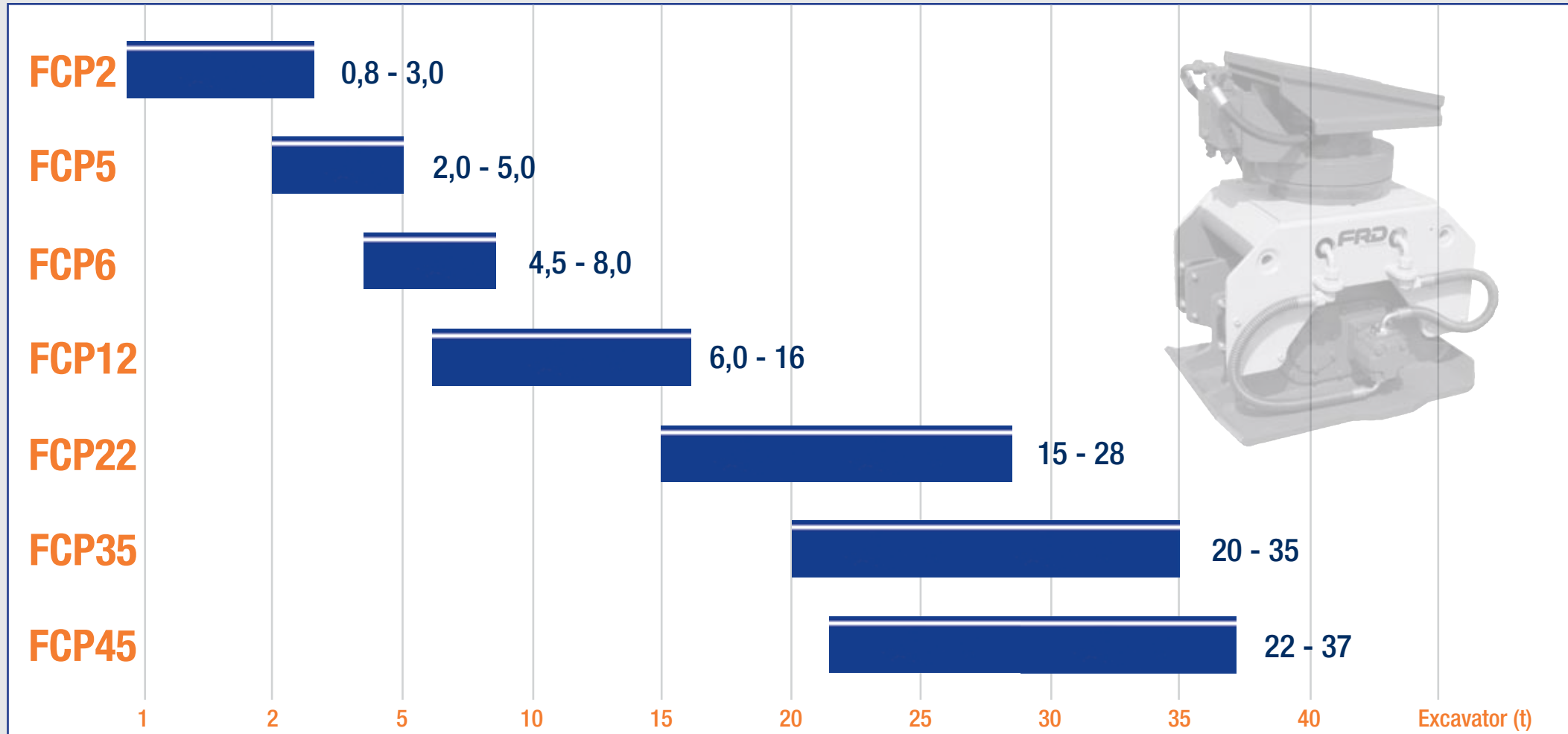

# COMPACTOR



## MAXIMUM DURABILITY

The FRD Compactor is designed for installation on all types hydraulic excavators and backhoe loaders. All Compactors are optionally available with a 2x 90 ° mechanical rotation device. The FRD Compactors combine high frequencies with high centrifugal force and guarantee thus an optimum soil compaction and in any position. Compared to conventional compactor rollers and stampers the FRD boom mounted compactors are able to work on steep slopes, trenches or rough terrain.



WHERE **EXPERIENCE COUNTS**

# FRD COMPACTOR

## FRD COMPACTOR - FCP SERIES -

		FCP2	FCP5	FCP6	FCP12	FCP22	FCP35	FCP45
Operating weight <sup>1)</sup>	kg	92	136	178	356	600	710	785
Base plate B x L	mm	440x320	450x450	510x450	610x760	710x850	870x750	940x750
Height <sup>2)</sup>	mm	370	370	390	610	700	780	780
Compaction area	m <sup>2</sup>	0,14	0,20	0,23	0,46	0,58	0,65	0,70
Centrifugal force	kN	10	18	25	50	95	155	205
Frequency	1/min	2200-2600	2200 - 3000	2200 - 3000	2100 - 2600	2200 - 2500	2400 - 2900	2400 - 2900
Oil flow	l/min	20 - 30	25 - 40	25 - 40	55 - 85	100 - 131	170 - 210	175 - 210
Working pressure	bar	120 - 140	120 - 140	120 - 140	120 - 140	120 - 140	190 - 215	200 - 220
Backpressure, return flow Max	bar	6	6	6	8	10	10	10
Internal hose Ø HD, ND	mm	9	12/16	12/16	16/19	19/25	25/32	25/32
Rotation, optional		2x90° mechanical / 360° endless hydraulic						
Mounting plate		F2LN	F2LN	F3LN	F6LN	F12LN	F19LN	F19LN
Excavator	t	0,8 - 3,0	2,0 - 5,0	4,5 - 8,0	6,0 - 16	15 - 28	20 - 35	22 - 37

Specifications may change without prior notice by the manufacturer.

<sup>1)</sup> Operating weight without rotation and mounting plate, <sup>2)</sup> Height without rotation and mounting plate

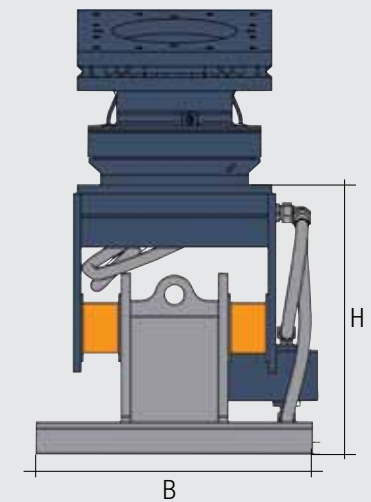
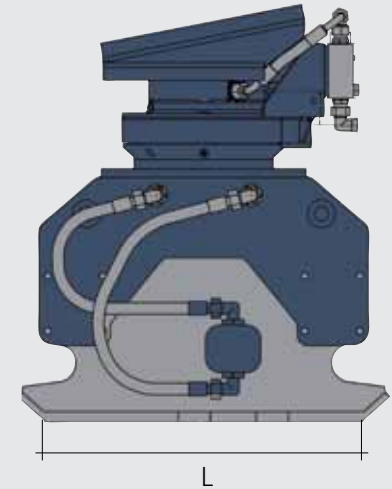

# COMPACTOR

Purpose

- Compaction of soil and granular materials.
- Compaction of trenches.
- Compaction of embankments, slopes, and dykes, where ordinary machines cannot be used.
- Detach frozen and sticky materials (coal, etc.)
- Driving of sheet piles (metal poles, fence posts, guard rails, etc.)

**FRD EXCAVATOR ATTACHMENTS:  
DEDICATED TO RELIABILITY AND LOWEST LIFETIME COST**



**FCP2**



**FCP12**



**FCP22HR**

WHERE **EXPERIENCE COUNTS**



# WHERE EXPERIENCE COUNTS

**Distributor:**

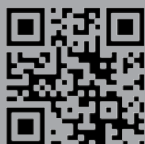
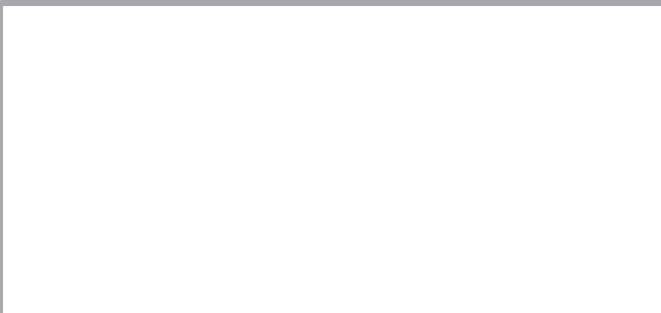

**Furukawa Rock Drill Europe BV**

Proostwetering 29, 3543 AB Utrecht, The Netherlands  
Phone +31-(0)30-2412277, Fax +31-(0)30-2412305  
FRD@FRD.eu / www.frd.eu