

Volvo Construction Equipment
Building Tomorrow



EC220E

Volvo Excavators 20.6-25.8 t 175 hp



Best in Class Efficiency

The EC220E builds on its efficiency reputation from the D-Series by ensuring all components work together and complement each other. The enhancements deliver the best in class fuel efficiency while not compromising on power – reducing emissions and consumption, while increasing productivity.

Volvo engine

Featuring proven advanced technology, and built on decades of experience, Volvo's robust D6 Stage V engine boasts more power - while reducing both fuel consumption and emissions to deliver superior quality, reliability and durability.



Increased power

The increased pump input power creates a highly responsive operation resulting in greater productivity and faster cycle time.

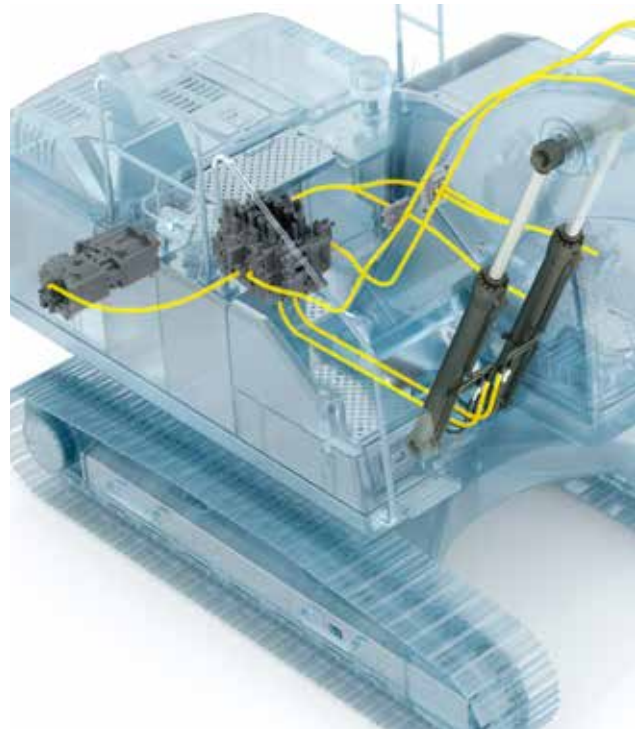

Boom float function

With the boom float function, the pump power for boom lowering can be saved or used for other functions, reducing the cycle time. Also, the grading operation can be made easier.



Main Control Valve and Software

The valve is compatible with software in the machine to aid controllability, by providing smooth and easy operation. In addition to increased swing force, the EC220E also comes with a boom swing priority valve; this enhances controllability of the swing and boom operation – making it ideal for loading trucks.

Auto engine shutdown

To reduce fuel consumption, the engine will automatically switch off when the machine is inactive for a pre-set amount of time (five minutes is the default setting).



OPTIMIZED HYDRAULICS

The hydraulics system, combined with the fully electronic control system and advanced ECO mode, has been optimized to work in harmony with the D6 Stage V engine, to match the engine power, reduce power loss and improve controllability and response time.



HUMAN MACHINE INTERFACE (HMI)

All machine interfaces – including joysticks, keypad, panel and larger LCD monitor – are ergonomically designed for optimum control and efficiency, resulting in increased productivity and workplace wellbeing.. The number of switches have been simplified and climate control integrated into the keypad for easy adjustments.

First Choice for Comfort

The cab design puts the operator in the drivers' seat to control personal specifications - from climate control, to short-cut functions on the joystick. The spacious cab allows the operator to move comfortably, to create a working environment that naturally promotes increased productivity.

Side view camera

As well as the rear view camera, side view camera can be optionally available for customers' comfort. Both views are displayed on the colour monitor, creating a safer working environment, protecting the operator and personnel on the ground.



Short-cut key

For added convenience, functions such as windshield wipers, cameras, auto-mute or power max function can all be assigned a short-cut button on the joystick. This allows the operator to select a function during the application without disruption.



Bluetooth®

To aid operator convenience and support better productivity, you can now connect a Bluetooth device to the machine enabling the handsfree function.



Seatbelt warning alarm

If the seatbelt is not buckled when the ignition key is turned, an alarm is triggered in intervals along with a continuous visual alert. This emphasises our priority for operator safety.



Building on Foundations of Trust and Quality

Quality is one of Volvo's core values and it goes hand-in-hand with reliability and durability. The EC220E pays particular attention to having all the components working at a high level of capacity but also being built to stand the test of time – providing the customer and operator with peace of mind.

ROPS

The cab features ROPS – this reinforced steel structure ensures the operator is protected in the unlikely event of the machine rolling over, while it also meets the ISO standards for safety.



Boom and Arm

The robust design includes internal plates positioned to support pressure points during the range of applications. This helps disperse the stress from high-pressure areas of the boom and arm, to ensure maximum productivity time after time, during the most demanding applications.



Lower frame

The intelligently designed X-shape lower frame enables even weight distribution increasing stability and durability - preventing damage from rock and debris.



Narrow and Heavy-duty (NH) Undercarriage

The EC220E NH's oversized and heavy-duty undercarriage creates excellent tractive force for improved durability and reliability in demanding terrain. A robust undercarriage increases the service life of the machine.





BUILT TO LAST

Working in tough conditions means every component matters - this is why Volvo pays extra attention to each detail during the manufacturing and product design processes. Silicone caulking is used to prevent rust, waterproof harnesses and connections are installed - as well as heavy-duty door hinges and bolted-on protection for the frame-work lights.



ULTIMATE TOOL CARRIER

The machine can be adjusted to take a wide variety of hydraulic lines, which are factory fitted with breaker and shear piping (X1), as well as rotator piping (X3). State-of-the-art auxiliary lines provide the correct flow and pressure for special attachments such as mowers and grinders, shears, crushers and tilt rotators among other attachments. You can choose between the one or two pump flow to maximize profits and productivity.

Customer Choice

Creating a machine that can adapt to a number of attachments increases productivity and reduces cycle time. The EC220E not only manages to achieve this versatility but it is a machine that incorporates the same high quality performance across its entire menu of applications – meaning the operator is safe in the knowledge that with Volvo there is no better option.

Attachment Management System

The password protected management system allows storage for up to 20 different attachments. It pre-sets and permits hydraulic flow and pressure to be adjusted within the cab, which ensures the use of various attachments for increased versatility.



Extra piping

An additional piping solution is available on the breaker and shear piping (X1), accommodating the use of tilt/rotator attachments.



Electrical pedal

The electric pedal offers precise control to allow the operator to use a wider variety of attachments.



Response mode

The attachment response sensitivity can be adjusted using the keypad. This allows the operator to tailor machine response for maximum impact in different environments.



Proactive Maintenance Solutions

Maintaining your machine will ensure you get the maximum lifetime and productivity. This is why Volvo have made this process easy – developing it to be fast, regular and safe.

Full size fold-able guard rails

Multiple sturdy handrails and fold-able guardrails provide safe and easy access to the superstructure for inspection and maintenance. The fold-able guardrail is to minimize transportation height when it is folded.



Single layer cooling system

The radiator, charged air cooler and hydraulic oil cooler are situated side-by-side on a single layer, to maximize efficiency, reduce blockages and aid cleaning. The system is easily accessed from ground level by simply opening the side door.

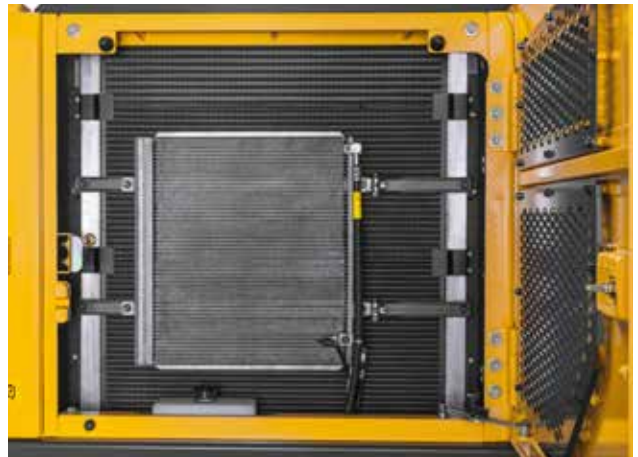

Service interval alerts

Real-time service alerts are displayed on the colour monitor to enable diagnostic checks. Separate service intervals include – the engine oil/ filter, fuel filter/water separator, hydraulic oil and hydraulic oil filter. This ensures peace of mind and maximum uptime.



Anti-slip steel plates

Well-positioned punched anti-slip plates provide superior grip and durability. The design facilitates easy cleaning while promoting safety.





GROUPED FILTERS

Maintaining a good level of inspection is important for machine longevity and that is why Volvo has grouped filters together, making them easily accessible for regular checks to maximize machine uptime.

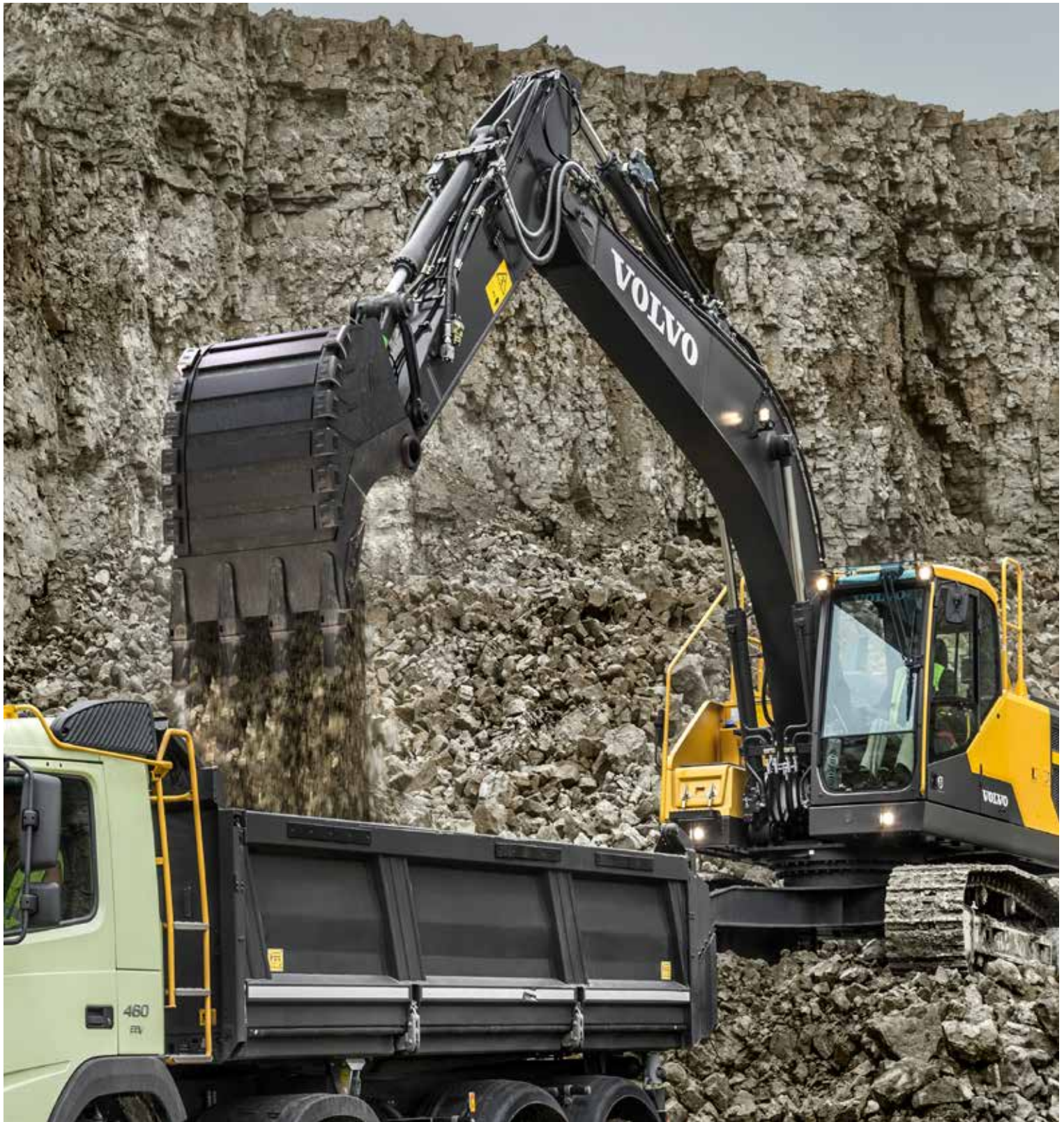

MATCHED ATTACHMENTS

Volvo's durable attachments have been purpose-built to work in perfect harmony with Volvo machines, forming one solid, reliable unit. With functions and properties ideally matched, Volvo attachments are an integrated part of the excavator for which they're intended.

Mix and match for a superior fit

Maximize your productivity and profitability with Volvo's EC220E crawler excavator and a range of durable attachments. Increase your versatility, access more applications and perform a variety of tasks – all while experiencing faster cycle times and excellent control.

Buckets – GP/HD/XD

Volvo's buckets are the perfect tool for digging and re-handling in all conditions from soft, medium and hard materials. Heavy-duty buckets are intended for productive digging in compact materials. All provide maximum productivity and long life and feature original Volvo wear components.



Breakers HB21, HB22

The HB-Series of hydraulic breakers are optimized to the specific weights of Volvo machines and tailored to Volvo quick couplers for swift, safe and simple attachment changes. They are available with a full assortment of tools.



Quick Coupler

Volvo offers a full range of quick couplers, from its dedicated Volvo S-type coupler to the Steelwrist® ones. Both couplers feature Front Pin Lock technology, which allows supreme safety when changing attachments. Those innovative couplers are not only designed to fit perfectly with Volvo excavators but they also comply with the latest safety regulations of ISO 13031 and EN474-1. Steelwrist® is a registered trademark of Steelwrist AB



Tilt Rotator

Volvo's tilt rotator can be ordered factory installed with multifunctional joysticks and color display that's fully integrated into the machine's system. The new series of Volvo XD excavator buckets are perfectly matched to the factory installed tilt rotator.



Improved total cost of ownership

Boom and Arm

To achieve the best performance, select the most suitable boom and arm configuration combination for your requirements.

ULTIMATE TOOL CARRIER

Designed to not only be compatible with a range of attachments, but also to enhance their performance by easily and quickly switching to accommodate any needs.

OPTIMIZED HYDRAULICS

Designed to perfectly match the engine power, reduce power loss, and improve controllability and response time.

AdBlue®

Volvo offers a total AdBlue solution that is quality assured, cost efficient and easily accessible. Contact your Volvo dealer for more information.

® = registered trademark of the Verband der Automobilindustrie e.V. (VDA)

Boom float function

The pump power for boom lowering can be saved or used for other functions, reducing the cycle time. Also, the grading operation can be made easier.

Attachment Management System

The password protected management system allows storage for up to 20 different attachments. It pre-sets and permits hydraulic flow and pressure to be adjusted within the cab.



Full size fold-able guard rails

Multiple sturdy handrails and fold-able guardrails provide safe and easy access to the super-structure for inspection and maintenance.

Side view camera

Covers the visual blind spot at the side of machine. View is displayed on the colour monitor, creating a safer working environment, protecting the operator and personnel on the ground.

HMI

All machine interfaces are ergonomically positioned and designed for optimum control and efficiency.

Bluetooth®

Bluetooth and hands-free functions have been added, allowing the operator to connect to wireless functions for increased comfort and safety.

Short-cut key

For ease of use, functions such as windshield wipers, cameras, auto-mute or power max function can all be assigned a short-cut button on the joystick.

Volvo engine

Volvo's efficient D6 Stage V engine gives you more power while consuming less fuel for low emission levels.

GROUPED FILTERS

Filters are well grouped and easily accessible from the ground level. This facilitates the speed and ease of servicing.

BUILT TO LAST

All detail – no matter how small - is overlooked. Silicone caulking is used to prevent rust, waterproof harnesses and connections have been installed - as well as heavy-duty door hinges and bolted-on protection for the framework lights.



Adding value to your business

Being a Volvo customer means having a complete set of services at your fingertips. Volvo can offer you a long-term partnership, protect your revenue and provide a full range of customer solutions using high quality parts, delivered by passionate people. Volvo is committed to increasing the positive return on your investment and maximising uptime.

Complete Solutions

Volvo has the right solution for you. So why not let us provide all your needs throughout the whole life cycle of your machine? By listening to your requirements, we can reduce your total cost of ownership and increase your revenue.

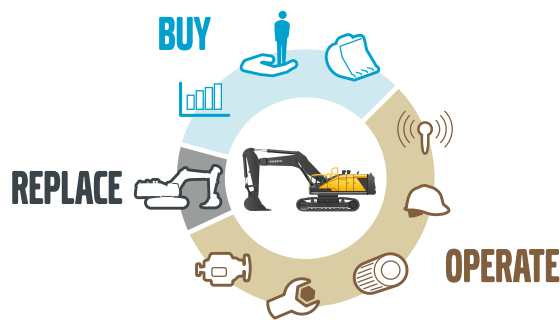

Perform with precision

Unlock the full potential of your machine's productivity with Dig Assist, the intelligent and intuitive technology which allows the operator to quickly and easily manage all excavator functions from a single in-cab system. Powered by the high resolution in-cab Volvo Co-Pilot, and with 2D, In-Field Design and 3D software packages available, Dig Assist gives operators access to a range of tools to help them achieve unmatched control, accuracy and uptime.



Genuine Volvo Parts

Our attention to detail is what makes us stand out. This proven concept acts as a solid investment in your machine's future. Parts are extensively tested and approved because every part is vital for uptime and performance. Only by using Genuine Volvo Parts, can you be sure that your machine retains the renowned Volvo quality.



Service Network

In order to respond to your needs faster, a Volvo expert is on their way to your job site from one of our Volvo facilities. With our extensive infrastructure of technicians, workshops and dealers, Volvo has a comprehensive network to fully support you using local knowledge and global experience.





CUSTOMER SUPPORT AGREEMENTS

The range of Customer Support Agreements offer preventive maintenance, total repairs and a number of uptime services. Volvo uses the latest technology to monitor machine operation and status, giving you advice to increase your profitability. By having a Customer Support Agreement you are in control of your service costs.

Volvo EC220E in detail

Engine

The latest generation, Volvo engine Stage V emissions compliant diesel engine fully meets the demands of the latest, emissions regulations. Featuring Volvo Advanced Combustion Technology (V-ACT), it is designed to deliver superior performance and fuel efficiency. The engine uses precise, high pressure fuel injectors, turbo charger and air-to-air intercooler, and electronic engine controls to optimize machine performance.

Air Filter: 3-stage with precleaner

Automatic Idling System: Reduces engine speed to idle when the levers and pedals are not activated resulting in less fuel consumption and low cab noise levels.

Engine	Volvo	D6J
Max power at	r/min	1 800
Net, ISO 9249/SAE J1349	kW	128
	hp	174
Gross, ISO 14396/SAE J1995	kW	129
	hp	175
Max torque	Nm	849
at engine speed	r/min	1 350
No. of cylinders		6
Displacement	l	5.7
Bore	mm	98
Stroke	mm	126

Electrical system

Well protected high-capacity electrical system. Waterproof double-lock harness plugs are used to secure corrosion-free connections. The main relays and solenoid valves are shielded to prevent damage. The master switch is standard.

Contronics provides advanced monitoring of machine functions and important diagnostic information.

Voltage	V	24
Batteries	V	2 x 12
Battery capacity	Ah	140
Alternator	V/A	28/80
Start motor	V - kW	24 - 5.5

Travel System

Each track is powered by an automatic two-speed shift travel motor. The track brakes are multi-disc, spring-applied and hydraulic released. The travel motor, brake and planetary gears are well protected within the track frame.

Max. drawbar pull	kN	183
Max. travel speed (low)	km/h	3.5
Max. travel speed (high)	km/h	5.7
Gradeability	°	35

Swing system

The swing system uses an axial piston motors, driving a planetary gearbox for maximum torque. An automatic holding brake and antirebound valve are standard

Max. slew speed	r/min	11.1
Max. slew torque	kNm	83

Undercarriage

Robust X-shaped frame with greased and sealed track chains as standard

EC220EL

Track shoe		2 x 49
Link pitch	mm	190
Shoe width, triple grouser	mm	500 / 600 / 700 / 800 / 900
Shoe width, triple grouser (HD)	mm	600
Shoe width, double grouser	mm	700
Shoe width, single grouser	mm	600
Bottom rollers		2 x 8
Top rollers		2 x 2

EC220ENL

Track shoe		2 x 49
Link pitch	mm	190
Shoe width, triple grouser	mm	500 / 600 / 700
Shoe width, triple grouser (HD)	mm	600
Shoe width, double grouser	mm	700
Bottom rollers		2 x 8
Top rollers		2 x 2

EC220EN

Track shoe		2 x 46
Link pitch	mm	190
Shoe width, triple grouser	mm	600 / 700 / 800 / 900
Shoe width, triple grouser (HD)	mm	600
Bottom rollers		2 x 7
Top rollers		2 x 2

EC220ENH

Track shoe		2 x 45
Link pitch	mm	203
Shoe width, triple grouser	mm	500 / 600 / 700
Bottom rollers		2 x 7
Top rollers		2 x 2

Hydraulic system

The hydraulics system, combined with the fully electronic control system and advanced ECO mode, has been optimized to work in harmony with engine to match the engine power, reduce power loss and improve controllability and response time.

The following important functions are included in the system:

Summation system: Combines the flow of both hydraulic pumps to ensure quick cycle times and high productivity.

Arm priority: Gives priority to the arm operation for faster cycle times in leveling and for increased bucket filling when digging.

Swing priority: Gives priority to swing functions for faster simultaneous operations.

Regeneration system: Prevents cavitation and provides flow to other movements during simultaneous operations for maximum productivity.

Power boost: All digging and lifting forces are increased.

Holding valves: Boom and arm holding valves prevent the digging equipment from creeping.

Main pump: 2 x variable displacement axial piston pumps

Maximum flow	l/min	2 x 207
--------------	-------	---------

Pilot pump: Gear pump

Maximum flow	l/min	1 x 18
--------------	-------	--------

Relief value setting pressure

Implement	MPa	34.3 / 36.3
-----------	-----	-------------

Travel circuit	MPa	34
----------------	-----	----

Slew circuit	MPa	28
--------------	-----	----

Pilot circuit	MPa	4
---------------	-----	---

Travel: Variable displacement axial piston motor with mechanical brake

Slew: Fixed displacement axial piston motor with mechanical brake

Hydraulic Cylinders

Mono boom		2
-----------	--	---

Bore x Stroke	ø x mm	125 x 1 235
---------------	--------	-------------

2 piece boom		1
--------------	--	---

Bore x Stroke	ø x mm	160 x 1 070
---------------	--------	-------------

Arm		1
-----	--	---

Bore x Stroke	ø x mm	135 x 1 540
---------------	--------	-------------

Bucket		1
--------	--	---

Bore x Stroke	ø x mm	120 x 1 065
---------------	--------	-------------

Bucket for LR boom		1
--------------------	--	---

Bore x Stroke	ø x mm	100 x 865
---------------	--------	-----------

Service Refill

Fuel tank	l	320
DEF/AdBlue® tank	l	27
Hydraulic system, total	l	290
Hydraulic tank	l	140
Engine oil	l	25
Engine coolant	l	35
Slew reduction unit	l	6
Travel reduction unit	l	2 x 5.8

Cab

The operator's cab has easy access via a wide door opening. The cab is supported on hydraulic dampening mounts to reduce shock and vibration levels. These along with sound absorbing lining provide low noise levels. The cab has excellent all-round visibility. The front windshield can easily slide up into the ceiling, and the lower front glass can be removed and stored in the side door.

Integrated air-conditioning and heating system: The pressurized and filtered cab air is supplied by an automatically-controlled fan. The air is distributed throughout the cab from 14 vents.

Ergonomic operator's seat: The adjustable seat and joystick console move independently to accommodate the operator. The seat has nine different adjustments plus a seat belt for the operator's comfort and safety.

Sound Level

Sound pressure level in cab according to ISO 6396		
L _{pA} (standard)	dB	69
L _{pA} (tropical)	dB	70
External sound level according to ISO 6395 and EU Noise Directive 2000/14/EC		
L _{WA} (standard)	dB	102
L _{WA} (tropical)	dB	103

Specifications

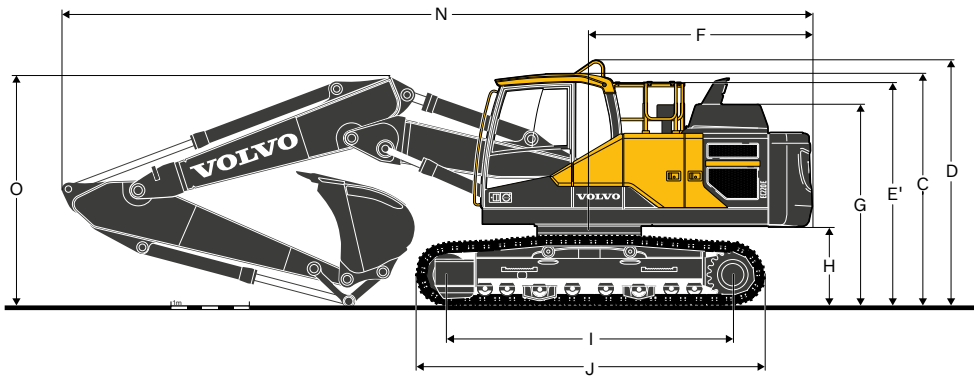
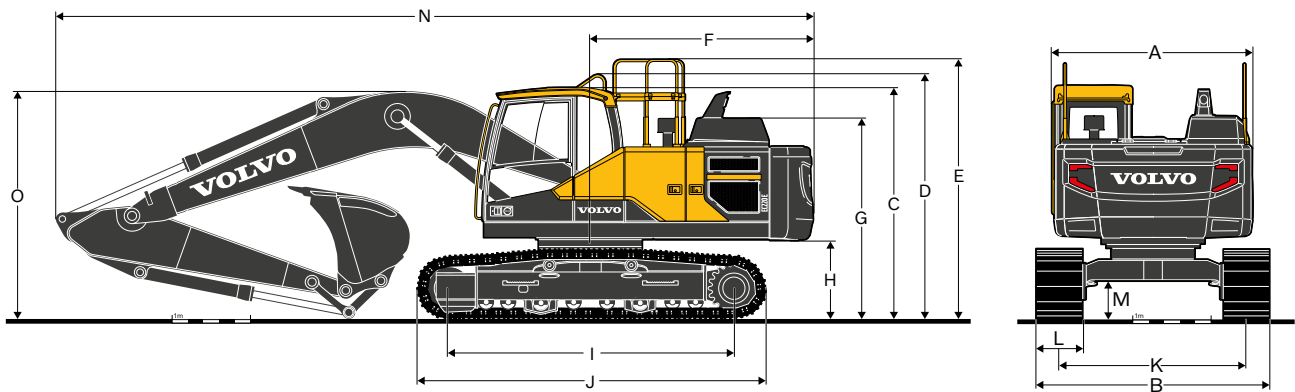

DIMENSIONS

Description	Unit	EC220EL				EC220ENL			
		5.7 mono or 5.57 2-piece				5.7 mono or 5.57 2-piece			
Boom	m	2.0	2.5	2.9	3.5	2.0	2.5	2.9	3.5
A. Overall width of upper structure	mm	2 540	2 540	2 540	2 540	2 540	2 540	2 540	2 540
B. Overall width	mm	2 990	2 990	2 990	2 990	2 540	2 540	2 540	2 540
C. Overall height of cab	mm	2 955	2 955	2 955	2 955	2 955	2 955	2 955	2 955
D. Overall height of handrail	mm	3 075	3 075	3 075	3 075	3 075	3 075	3 075	3 075
E. Overall height of guardrail(unfolded)	mm	3 270	3 270	3 270	3 270	3 270	3 270	3 270	3 270
E'. Overall height of guardrail(folded)	mm	2 790	2 790	2 790	2 790	2 790	2 790	2 790	2 790
F. Tail swing radius	mm	2 850	2 850	2 850	2 850	2 850	2 850	2 850	2 850
G. Overall height of engine hood	mm	2 600	2 600	2 600	2 600	2 600	2 600	2 600	2 600
H. Counterweight clearance *	mm	1 025	1 025	1 025	1 025	1 025	1 025	1 025	1 025
I. Tumbler length	mm	3 660	3 660	3 660	3 660	3 660	3 660	3 660	3 660
J. Track length	mm	4 460	4 460	4 460	4 460	4 460	4 460	4 460	4 460
K. Track gauge	mm	2 390	2 390	2 390	2 390	2 040	2 040	2 040	2 040
L. Shoe width	mm	600	600	600	600	500	500	500	500
M. Min. ground clearance *	mm	460	460	460	460	460	460	460	460
N. Overall length	mm	9 795	9 745	9 690	9 720	9 795	9 745	9 690	9 720
N1. Overall length	mm	9 660	9 610	9 570	9 560	9 660	9 610	9 570	9 560
O. Overall height of boom	mm	3 100	3 080	2 940	3 260	3 100	3 080	2 940	3 260
O1. Overall height of boom	mm	3 065	3 065	2 960	3 310	3 065	3 065	2 960	3 310

* Without shoe grouser.

1 2-piece boom

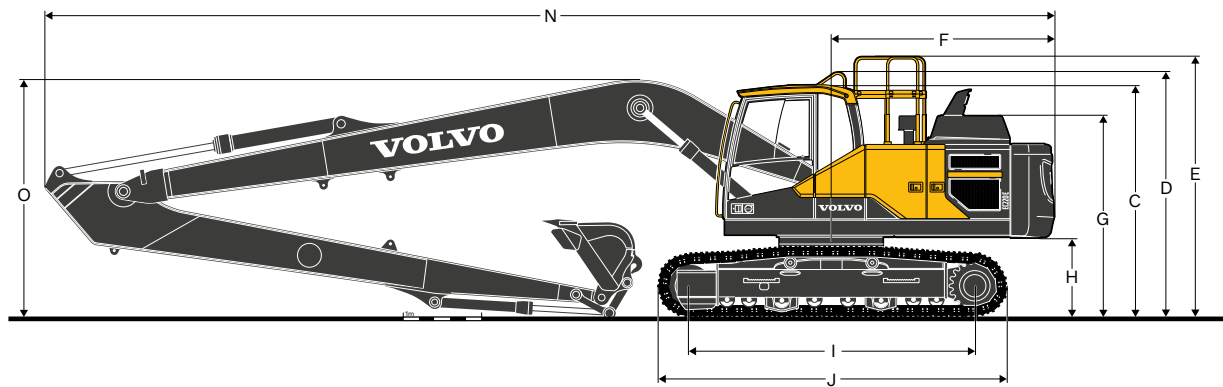

DIMENSIONS

Description	Unit	EC220EN				EC220ENH				EC220ELR
		5.7 mono or 5.57 2-piece				5.7 mono or 5.57 2-piece				8.85
Boom	m									
Arm	m	2.0	2.5	2.9	3.5	2.0	2.5	2.9	3.5	6.25
A. Overall width of upper structure	mm	2 540	2 540	2 540	2 540	2 540	2 540	2 540	2 540	2 540
B. Overall width	mm	2 800	2 800	2 800	2 800	2 540	2 540	2 540	2 540	3 190
C. Overall height of cab	mm	2 955	2 955	2 955	2 955	3 020	3 020	3 020	3 020	2 955
D. Overall height of handrail	mm	3 075	3 075	3 075	3 075	3 140	3 140	3 140	3 140	3 075
E. Overall height of guardrail(unfolded)	mm	3 270	3 270	3 270	3 270	3 335	3 335	3 335	3 335	3 270
E'. Overall height of guardrail(folded)	mm	2 790	2 790	2 790	2 790	2 855	2 855	2 855	2 855	2 790
F. Tail swing radius	mm	2 850	2 850	2 850	2 850	2 850	2 850	2 850	2 850	2 850
G. Overall height of engine hood	mm	2 600	2 600	2 600	2 600	2 665	2 665	2 665	2 665	2 600
H. Counterweight clearance *	mm	1 025	1 025	1 025	1 025	1 090	1 090	1 090	1 090	1 025
I. Tumbler length	mm	3 370	3 370	3 370	3 370	3 510	3 510	3 510	3 510	3 660
J. Track length	mm	4 160	4 160	4 160	4 160	4 360	4 360	4 360	4 360	4 460
K. Track gauge	mm	2 200	2 200	2 200	2 200	2 040	2 040	2 040	2 040	2 390
L. Shoe width	mm	600	600	600	600	500	500	500	500	800
M. Min. ground clearance *	mm	460	460	460	460	490	490	490	490	460
N. Overall length	mm	9 795	9 745	9 690	9 720	9 795	9 745	9 690	9 720	12 880
N1. Overall length	mm	9 660	9 610	9 570	9 560	9 660	9 610	9 570	9 560	-
O. Overall height of boom	mm	3 100	3 080	2 940	3 260	3 100	3 080	2 940	3 260	3 055
O1. Overall height of boom	mm	3 065	3 065	2 960	3 310	3 065	3 065	2 960	3 310	-

* Without shoe grouser.

1 2-piece boom

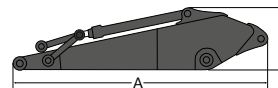
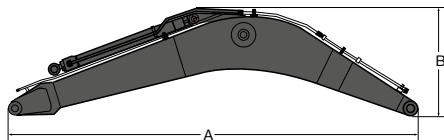

DIMENSIONS

Description	Unit	Boom				Arm						Long-Reach	
		mono	mono	2-piece	Long-Reach	Description	Unit	2.0	2.5	2.9	2.9 HD		3.5
Boom	m	5.7	5.7 HD	5.57	8.85	Arm	m	2.0	2.5	2.9	2.9 HD	3.5	6.25
Length	mm	5 910	5 910	5 780	9 060	Length	mm	3 065	3 525	3 910	3 910	4 540	7 330
Height	mm	1 585	1 585	1 570	1 460	Height	mm	980	860	860	860	855	945
Width	mm	670	670	670	670	Width	mm	440	440	440	440	440	385
Weight	kg	2 006	2 151	2 585	2 510	Weight	kg	1 091	1 133	1 146	1 183	1 226	1 309

* Includes cylinder, piping and pin, excludes boom cylinder pin

* Includes cylinder, linkage and pin

Specifications

MACHINE WEIGHTS AND GROUND PRESSURE

Description	Shoe width	Operating weight	Ground pressure	Overall width	Operating weight	Ground pressure	Overall width
	mm	kg	kPa	mm	kg	kPa	mm
		EC220EL					
		5.7m boom, 2.9m arm, 820kg / 0.92m³ bucket, 4 200kg counterweight			5.57m 2-piece, 2.9m arm, 820kg / 0.92m³ bucket, 4 200kg counterweight		
Triple grouser	500	21 440	53.0	2 890	22 130	54.9	2 890
	600	21 700	45.1	2 990	22 385	46.1	2 990
	700	22 160	39.2	3 090	22 840	40.2	3 090
	800	22 445	35.3	3 190	23 130	36.3	3 190
	900	22 740	31.4	3 290	23 420	32.4	3 290
Triple grouser HD	600	21 870	45.1	2 990	22 550	47.1	2 990
Double grouser	700	22 425	40.2	3 090	23 110	41.2	3 090
Single grouser	600	21 910	45.1	2 990	22 590	47.1	2 990
		EC220ENL					
		5.7m boom, 2.9m arm, 820kg / 0.92m³ bucket, 5 000kg counterweight			5.57m 2-piece, 2.9m arm, 820kg / 0.92m³ bucket, 5 000kg counterweight		
Triple grouser	500	22 150	54.9	2 540	22 840	56.9	2 540
	600	22 410	46.1	2 640	23 100	48.0	2 640
	700	22 870	40.2	2 740	23 560	42.2	2 740
Triple grouser HD	600	22 580	47.1	2 640	23 265	48.0	2 640
Double grouser	700	23 140	41.2	2 740	23 820	42.2	2 740
		EC220EN					
		5.7m boom, 2.9m arm, 820kg / 0.92m³ bucket, 4 200kg counterweight			5.57m 2-piece, 2.9m arm, 820kg / 0.92m³ bucket, 4 200kg counterweight		
Triple grouser	600	21 280	48.0	2 800	21 960	49.0	2 800
	700	21 710	41.2	2 900	22 395	43.1	2 900
	800	21 980	37.3	3 000	22 660	38.2	3 000
	900	22 220	33.3	3 100	22 900	34.3	3 100
Triple grouser HD	600	21 440	48.0	2 800	22 120	50.0	2 800
		EC220ENH					
		5.7m boom, 2.9m arm, 820kg / 0.92m³ bucket, 5 000kg counterweight			5.57m 2-piece, 2.9m arm, 820kg / 0.92m³ bucket, 5 000kg counterweight		
Triple grouser	500	23 270	62.8	2 540	23 960	64.7	2 540
	600	23 590	53.0	2 640	24 270	53.9	2 640
	700	24 110	46.1	2 740	24 790	48.0	2 740
		EC220ELR					
		8.85m boom, 6.25m arm, 452kg / 0.52m³ bucket, 5 000kg counterweight					
Triple grouser	800	23 690	37.3	3 190			
	900	23 990	33.3	3 290			

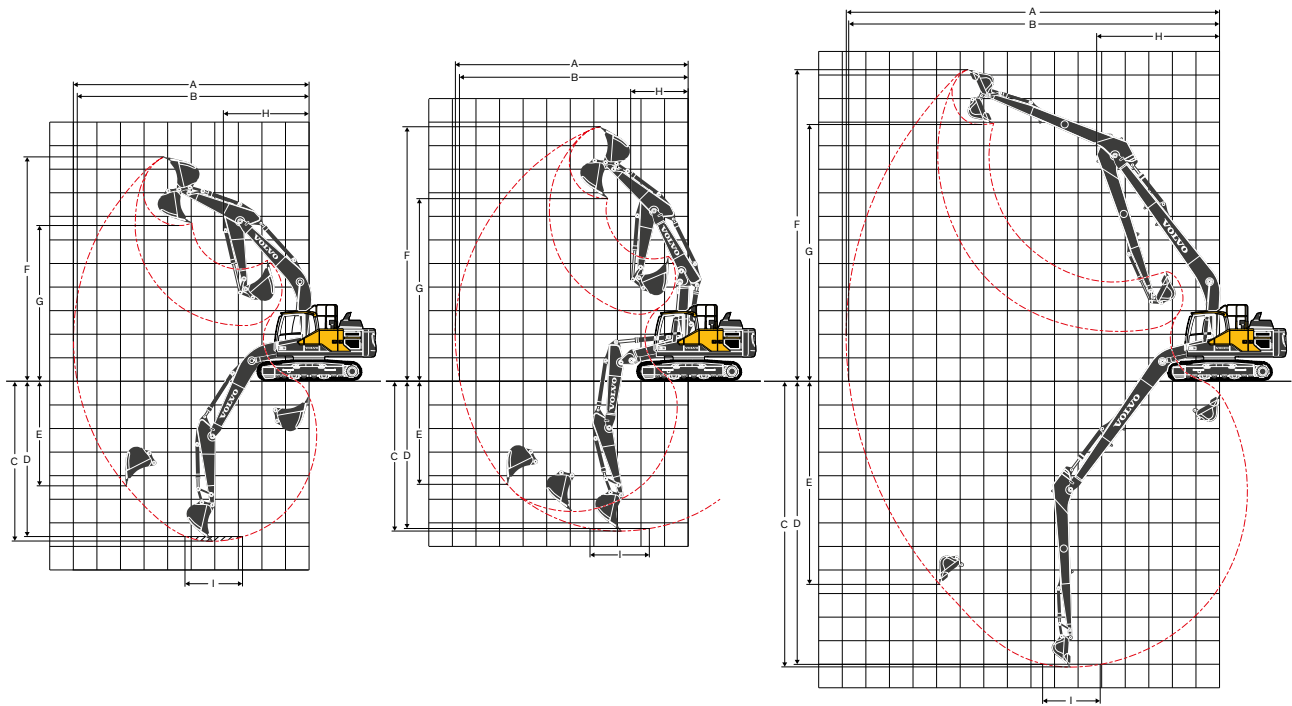

WORKING RANGES

Description	Unit	EC220EL/EC220ENL/EC220EN								EC220ELR
		5.7 mono				5.57 2-piece				
Boom	m									8.85
Arm	m	2.0	2.5	2.9	3.5	2.0	2.5	2.9	3.5	6.25
A. Max. digging reach	mm	9 090	9 550	9 930	10 390	8 980	9 450	9 840	10 310	15 800
B. Max. digging reach on ground	mm	8 910	9 380	9 770	10 240	8 800	9 280	9 670	10 150	15 700
C. Max. digging depth	mm	5 830	6 330	6 730	7 330	5 410	5 900	6 300	6 850	12 100
D. Max. digging depth (2.44 m level)	mm	5 560	6 100	6 540	7 130	5 290	5 790	6 200	6 750	12 000
E. Max. vertical wall digging depth	mm	4 880	5 620	6 090	6 470	4 390	4 990	5 410	5 930	11 290
F. Max. cutting height	mm	8 940	9 220	9 460	9 460	10 010	10 380	10 710	10 920	13 300
G. Max. dumping height	mm	6 190	6 430	6 650	6 700	7 100	7 460	7 780	8 010	10 950
H. Min. front swing radius	mm	3 790	3 670	3 640	3 660	2 890	2 740	2 470	2 730	5 200

Description	Unit	EC220ENH								
		5.7 mono				5.57 2-piece				
Boom	m	-								
Arm	m	-	2.0	2.5	2.9	3.5	2.0	2.5	2.9	3.5
A. Max. digging reach	mm	-	9 090	9 550	9 930	10 390	8 980	9 450	9 840	10 310
B. Max. digging reach on ground	mm	-	8 910	9 380	9 770	10 240	8 800	9 280	9 670	10 150
C. Max. digging depth	mm	-	5 760	6 260	6 660	7 260	5 340	5 830	6 230	6 780
D. Max. digging depth (2.44 m level)	mm	-	5 490	6 030	6 470	7 060	5 220	5 720	6 130	6 680
E. Max. vertical wall digging depth	mm	-	4 810	5 550	6 020	6 400	4 320	4 920	5 340	5 860
F. Max. cutting height	mm	-	9 010	9 290	9 530	9 530	10 080	10 450	10 780	10 990
G. Max. dumping height	mm	-	6 260	6 500	6 720	6 770	7 170	7 530	7 850	8 080
H. Min. front swing radius	mm	-	3 790	3 670	3 640	3 660	2 890	2 740	2 470	2 730

DIGGING FORCES WITH DIRECT FIT BUCKET

Bucket radius	mm	1 528	1 528	1 528	1 528	1 528	1 528	1 528	1 528	1 528	1 250	
Breakout force - bucket	Normal	SAE J1179	kN	146	125	125	125	146	125	125	125	68
	Power boost	SAE J1179	kN	154	132	132	132	154	132	132	132	-
	Normal	ISO 6015	kN	165	141	141	141	165	141	141	141	77
	Power boost	ISO 6015	kN	174	149	149	149	174	149	149	149	-
Tearout force - dipper arm	Normal	SAE J1179	kN	144	117	101	92	144	117	101	92	44
	Power boost	SAE J1179	kN	153	124	107	97	153	124	107	97	-
	Normal	ISO 6015	kN	149	121	104	94	149	121	104	94	45
	Power boost	ISO 6015	kN	158	128	110	99	158	128	110	99	-
Rotation angle, bucket	°	166	175	175	175	175	175	175	175	175	178	

Specifications

BUCKET SELECTION GUIDE

Bucket type		Capacity	Cutting width	Weight	Teeth	EC220EL							
						5.7m Boom				5.57m 2-piece			
						600mm shoe, 4 200kg counterweight				600mm shoe, 4 200kg counterweight			
						L	mm	kg	EA	2.0m	2.5m	2.9m	3.5m
Direct fit Buckets	General purpose	480	600	623	3	C	C	C	C	C	C	C	C
		630	800	703	4	C	C	C	C	C	C	C	C
		750	900	749	4	C	C	C	C	C	C	C	C
		920	1 050	819	4	C	C	C	C	C	C	C	C
		1 090	1 200	908	5	C	C	C	C	C	C	C	C
		1 270	1 350	995	5	C	C	C	B	C	C	C	B
1 440	1 500	1 085	6	C	C	B	A	C	C	B	A		
Bucket type		Capacity	Cutting width	Weight	Teeth	EC220ENL							
						5.7m Boom				5.57m 2-piece			
						600mm shoe, 5 000kg counterweight				600mm shoe, 5 000kg counterweight			
						L	mm	kg	EA	2.0m	2.5m	2.9m	3.5m
Direct fit Buckets	General purpose	480	600	623	3	C	C	C	C	C	C	C	C
		630	800	703	4	C	C	C	C	C	C	C	C
		750	900	749	4	C	C	C	C	C	C	C	C
		920	1 050	819	4	C	C	C	C	C	C	C	C
		1 090	1 200	908	5	C	C	C	C	C	C	C	C
		1 270	1 350	995	5	C	C	C	C	C	C	C	C
1 440	1 500	1 085	6	C	C	C	B	C	C	C	B		
Bucket type		Capacity	Cutting width	Weight	Teeth	EC220EN							
						5.7m Boom				5.57m 2-piece			
						600mm shoe, 4 200kg counterweight				600mm shoe, 4 200kg counterweight			
						L	mm	kg	EA	2.0m	2.5m	2.9m	3.5m
Direct fit Buckets	General purpose	480	600	623	3	C	C	C	C	C	C	C	C
		630	800	703	4	C	C	C	C	C	C	C	C
		750	900	749	4	C	C	C	C	C	C	C	C
		920	1 050	819	4	C	C	C	C	C	C	C	C
		1 090	1 200	908	5	C	C	C	C	C	C	C	C
		1 270	1 350	995	5	C	C	C	B	C	C	C	B
1 440	1 500	1 085	6	C	C	B	A	C	C	B	A		
Bucket type		Capacity	Cutting width	Weight	Teeth	EC220ENH							
						5.7m Boom				5.57m 2-piece			
						600mm shoe, 5 000kg counterweight				600mm shoe, 5 000kg counterweight			
						L	mm	kg	EA	2.0m	2.5m	2.9m	3.5m
Direct fit Buckets	General purpose	480	600	623	3	C	C	C	C	C	C	C	C
		630	800	703	4	C	C	C	C	C	C	C	C
		750	900	749	4	C	C	C	C	C	C	C	C
		920	1 050	819	4	C	C	C	C	C	C	C	C
		1 090	1 200	908	5	C	C	C	C	C	C	C	C
		1 270	1 350	995	5	C	C	C	C	C	C	C	C
1 440	1 500	1 085	6	C	C	C	B	C	C	C	B		

Please consult with your Volvo dealer for the proper match of buckets and attachments to suit the application. The recommendations are given as a guide only, based on typical operation conditions. Bucket capacity based on ISO 7451, heaped material with a 1:1 angle of repose.

Maximum material density

A	1 200~1 300 kg/m ³	Coal, Caliche, Shale
B	1 400~1 600 kg/m ³	Wet earth and clay, Limestone, Sandstone
C	1 700~1 800 kg/m ³	Granite, Wet sand, Well blasted rock
D	1 900 kg/m ³ ~	Wet mud, Iron ore

LIFTING CAPACITY EC220EL

Lifting capacity at the arm end without bucket.

For lifting capacity including bucket, simply subtract actual weight of the direct fit bucket or the bucket with quick coupler from the following values.

	Lifting hook related to ground level	1.5 m		3.0 m		4.5 m		6.0 m		7.5 m		9.0 m		Max. reach			
		Along UC	Across UC	Along UC	Across UC	Along UC	Across UC	Along UC	Across UC	Along UC	Across UC	Along UC	Across UC	Along UC	Across UC	m	
Boom: 5.7m Arm: 2.5m Shoe: 600mm CWT: 4 200kg	7.5 m	kg													*5 670	*5 670	5.6
	6.0 m	kg						*5 500	*5 500						*5 600	4 550	6.9
	4.5 m	kg					*7 000	*7 000	*6 020	5 520	*5 680	3 890			*5 690	3 800	7.6
	3.0 m	kg					*9 020	8 010	*6 910	5 280	5 830	3 800			5 290	3 450	8.0
	1.5 m	kg					*10 780	7 530	*7 800	5 050	5 720	3 690			5 130	3 320	8.1
	0.0 m	kg					*11 570	7 310	7 810	4 900	5 640	3 620			5 260	3 390	7.9
	-1.5 m	kg			*10 840	*10 840	*11 480	7 280	7 760	4 850					5 780	3 700	7.4
	-3.0 m	kg			*14 760	14 420	*10 560	7 390	*7 790	4 920					*7 010	4 470	6.5
	-4.5 m	kg			*11 400	*11 400	*8 140	7 670							*7 150	6 690	5.0
Boom: 5.7m Arm: 2.9m Shoe: 600mm CWT: 4 200kg	7.5 m	kg							*5 180	*5 180					*4 910	*4 910	6.2
	6.0 m	kg						*5 080	*5 080						*4 580	4 150	7.3
	4.5 m	kg						*5 660	5 600	*5 350	3 940				*4 520	3 530	8.0
	3.0 m	kg					*8 440	8 160	*6 590	5 350	*5 750	3 840			*4 640	3 230	8.4
	1.5 m	kg					*10 370	7 640	*7 570	5 100	5 740	3 710			4 800	3 110	8.5
	0.0 m	kg			*5 420	*5 420	*11 430	7 350	7 840	4 920	5 640	3 620			4 910	3 170	8.3
	-1.5 m	kg	*6 270	*6 270	*10 320	*10 320	*11 590	7 280	7 750	4 840	5 610	3 590			5 330	3 430	7.8
	-3.0 m	kg	*11 380	*11 380	*15 660	14 300	*10 930	7 340	7 790	4 880					6 320	4 040	6.9
	-4.5 m	kg			*12 740	*12 740	*9 050	7 560							*6 920	5 600	5.6
Boom: 5.7m Arm: 3.5m Shoe: 600mm CWT: 4 200kg	7.5 m	kg													*4 900	4 370	7.1
	6.0 m	kg								*4 610	4 050				*4 850	3 500	8.1
	4.5 m	kg							*4 860	*4 860	*4 750	3 980			4 670	3 050	8.8
	3.0 m	kg							*5 740	5 400	*5 170	3 840	4 410	2 860	4 340	2 810	9.1
	1.5 m	kg							*6 720	5 110	*5 680	3 700	4 350	2 800	4 220	2 720	9.2
	0.0 m	kg							*7 520	4 880	5 600	3 570			4 300	2 760	9.0
	-1.5 m	kg					*10 750	7 160	7 670	4 760	5 530	3 510			4 610	2 950	8.6
	-3.0 m	kg			*15 300	13 960	*10 470	7 170	7 660	4 750	5 550	3 530			5 280	3 370	7.8
	-4.5 m	kg	*16 720	*16 720	*13 020	*13 020	*9 260	7 330	*6 830	4 880					*5 830	4 320	6.6
Boom: 5.57m 2-piece Arm: 2.0m Shoe: 600mm CWT: 4 200kg	7.5 m	kg					*8 610	*8 610							*8 490	8 090	4.8
	6.0 m	kg					*8 600	*8 600	*7 490	5 530					*7 420	5 260	6.2
	4.5 m	kg					*9 600	8 430	*7 690	5 400					6 560	4 220	7.0
	3.0 m	kg					*10 920	7 780	*8 160	5 150					5 870	3 760	7.4
	1.5 m	kg							7 910	4 920	5 680	3 610			5 670	3 600	7.5
	0.0 m	kg					*10 900	7 160	7 760	4 790					5 860	3 700	7.3
	-1.5 m	kg					*9 390	7 190	*7 140	4 800					*5 910	4 140	6.7
	-3.0 m	kg					*6 710	*6 710									5.7
	Boom: 5.57m 2-piece Arm: 2.5m Shoe: 600mm CWT: 4 200kg	7.5 m	kg					*7 840	*7 840							*6 800	6 530
6.0 m		kg					*8 000	*8 000	*7 020	5 660					*6 230	4 630	6.7
4.5 m		kg			*12 730	*12 730	*9 040	8 630	*7 360	5 500					5 920	3 830	7.5
3.0 m		kg					*10 490	7 990	*7 930	5 230	5 820	3 730			5 370	3 450	7.9
1.5 m		kg					*11 420	7 440	7 970	4 980	5 690	3 620			5 190	3 310	8.0
0.0 m		kg					*11 250	7 190	7 780	4 810	5 610	3 550			5 340	3 380	7.8
-1.5 m		kg			*11 490	*11 490	*10 080	7 160	*7 590	4 770					*5 700	3 720	7.3
-3.0 m		kg					*7 830	7 290	*5 670	4 870					*5 010	4 540	6.3
Boom: 5.57m 2-piece Arm: 2.9m Shoe: 600mm CWT: 4 200kg		9.0 m	kg													*6 130	*6 130
	7.5 m	kg					*7 030	*7 030	*5 140	*5 140					*4 940	*4 940	6.0
	6.0 m	kg					*7 080	*7 080	*6 680	5 760					*4 560	4 210	7.2
	4.5 m	kg			*9 140	*9 140	*8 560	*8 560	*7 090	5 590	5 990	3 890			*4 470	3 550	7.9
	3.0 m	kg					*10 090	8 160	*7 720	5 310	5 870	3 780			*4 570	3 220	8.3
	1.5 m	kg					*11 260	7 560	8 030	5 030	5 720	3 650			*4 850	3 100	8.4
	0.0 m	kg			*5 940	*5 940	*11 410	7 240	7 810	4 840	5 620	3 550			4 970	3 160	8.2
	-1.5 m	kg			*10 850	*10 850	*10 530	7 150	7 720	4 760	5 600	3 530			5 420	3 430	7.7
	-3.0 m	kg			*10 990	*10 990	*8 600	7 240	*6 370	4 810					*4 980	4 080	6.8

Notes: 1. Machine in "Fine Mode-F" (Power Boost) for lifting capacities. 2. The above loads are in compliance with SAE J1097 and ISO 10567 Hydraulic Excavator Lifting Capacity Standards. 3. Rated loads do not exceed 87% of hydraulic lifting capacity or 75% of tipping load. 4. Rated loads marked with an asterisk (*) are limited by hydraulic capacity rather than tipping load.

Specifications

LIFTING CAPACITY EC220ENL

Lifting capacity at the arm end without bucket.

For lifting capacity including bucket, simply subtract actual weight of the direct fit bucket or the bucket with quick coupler from the following values.

	Lifting hook related to ground level	1.5 m		3.0 m		4.5 m		6.0 m		7.5 m		9.0 m		Max. reach		
		Along UC	Across UC	Along UC	Across UC	Along UC	Across UC	Along UC	Across UC	Along UC	Across UC	Along UC	Across UC	Along UC	Across UC	m
Boom : 5.7m HD Arm : 2.0m ME Shoe : 500mm CWT : 5 000kg	7.5 m kg	-	-	-	-	-	-	-	-	-	-	-	-	*6 270	*6 270	4.9 m
	6.0 m kg	-	-	-	-	-	-	*6 020	5 140	-	-	-	-	*6 060	4 730	6.3 m
	4.5 m kg	-	-	-	-	*7 650	7 640	*6 410	5 000	-	-	-	-	*6 100	3 850	7.1 m
	3.0 m kg	-	-	-	-	*9 620	7 050	*7 210	4 760	6 130	3 450	-	-	6 110	3 440	7.5 m
	1.5 m kg	-	-	-	-	-	-	*7 980	4 550	6 030	3 360	-	-	5 900	3 300	7.6 m
	0.0 m kg	-	-	-	-	*11 520	6 510	8 240	4 430	-	-	-	-	6 100	3 380	7.4 m
	-1.5 m kg	-	-	-	-	*11 130	6 530	8 230	4 420	-	-	-	-	6 810	3 740	6.9 m
	-3.0 m kg	-	-	*13 280	12 560	*9 870	6 690	-	-	-	-	-	-	*7 320	4 690	5.9 m
Boom : 5.7m HD Arm : 2.5m HD Shoe : 500mm CWT : 5 000kg	7.5 m kg	-	-	-	-	-	-	-	-	-	-	-	-	*5 640	*5 640	5.6 m
	6.0 m kg	-	-	-	-	-	-	*5 470	5 260	-	-	-	-	*5 570	4 210	6.9 m
	4.5 m kg	-	-	-	-	*6 960	*6 960	*5 990	5 100	*5 640	3 590	-	-	*5 650	3 520	7.6 m
	3.0 m kg	-	-	-	-	*8 960	7 260	*6 860	4 850	*5 950	3 500	-	-	5 610	3 180	8.0 m
	1.5 m kg	-	-	-	-	*10 700	6 780	*7 750	4 620	6 070	3 400	-	-	5 440	3 060	8.1 m
	0.0 m kg	-	-	-	-	*11 480	6 560	8 280	4 460	5 980	3 320	-	-	5 590	3 110	7.9 m
	-1.5 m kg	-	-	*10 840	*10 840	*11 390	6 530	8 230	4 420	-	-	-	-	6 140	3 400	7.4 m
	-3.0 m kg	-	-	*14 640	12 430	*10 480	6 640	*7 730	4 490	-	-	-	-	*6 950	4 100	6.5 m
-4.5 m kg	-	-	*11 290	*11 290	*8 060	6 920	-	-	-	-	-	-	*7 090	6 070	5.0 m	
Boom : 5.7m HD Arm : 2.9m GP Shoe : 500mm CWT : 5 000kg	7.5 m kg	-	-	-	-	-	-	*5 150	*5 150	-	-	-	-	*4 910	*4 910	6.2 m
	6.0 m kg	-	-	-	-	-	-	*5 050	*5 050	-	-	-	-	*4 580	3 850	7.3 m
	4.5 m kg	-	-	-	-	-	-	*5 630	5 170	*5 310	3 650	-	-	*4 520	3 270	8.0 m
	3.0 m kg	-	-	-	-	*8 390	7 410	*6 550	4 920	*5 710	3 540	-	-	*4 640	2 980	8.4 m
	1.5 m kg	-	-	-	-	*10 300	6 890	*7 510	4 670	6 100	3 420	-	-	*4 950	2 870	8.5 m
	0.0 m kg	-	-	*5 420	*5 420	*11 340	6 610	*8 210	4 490	5 990	3 330	-	-	5 210	2 910	8.3 m
	-1.5 m kg	*6 270	*6 270	*10 320	*10 320	*11 500	6 530	8 220	4 410	5 960	3 300	-	-	5 660	3 150	7.8 m
	-3.0 m kg	*11 380	*11 380	*15 530	12 320	*10 840	6 590	*8 020	4 450	-	-	-	-	*6 600	3 700	6.9 m
-4.5 m kg	-	-	*12 620	*12 620	*8 970	6 810	-	-	-	-	-	-	*6 860	5 110	5.6 m	
Boom : 5.7m HD Arm : 2.9m HD Shoe : 500mm CWT : 5 000kg	7.5 m kg	-	-	-	-	-	-	*5 130	*5 130	-	-	-	-	*4 900	*4 900	6.2 m
	6.0 m kg	-	-	-	-	-	-	*5 030	*5 030	-	-	-	-	*4 570	3 830	7.3 m
	4.5 m kg	-	-	-	-	-	-	*5 600	5 150	*5 280	3 630	-	-	*4 510	3 250	8.0 m
	3.0 m kg	-	-	-	-	*8 350	7 380	*6 510	4 890	*5 680	3 520	-	-	*4 630	2 960	8.4 m
	1.5 m kg	-	-	-	-	*10 250	6 850	*7 470	4 640	6 070	3 390	-	-	*4 940	2 840	8.5 m
	0.0 m kg	-	-	*5 410	*5 410	*11 290	6 560	*8 170	4 450	5 960	3 300	-	-	5 190	2 890	8.3 m
	-1.5 m kg	*6 260	*6 260	*10 310	*10 310	*11 450	6 480	8 190	4 380	5 930	3 270	-	-	5 630	3 120	7.8 m
	-3.0 m kg	*11 370	*11 370	*15 470	12 260	*10 790	6 550	*7 980	4 410	-	-	-	-	*6 570	3 670	6.9 m
-4.5 m kg	-	-	*12 570	*12 570	*8 930	6 770	-	-	-	-	-	-	*6 820	5 080	5.6 m	
Boom : 5.7m HD Arm : 3.5m GP Shoe : 500mm CWT : 5 000kg	7.5 m kg	-	-	-	-	-	-	-	-	-	-	-	-	*4 910	4 100	7.1 m
	6.0 m kg	-	-	-	-	-	-	-	-	*4 620	3 790	-	-	*4 860	3 280	8.1 m
	4.5 m kg	-	-	-	-	-	-	*4 880	*4 880	*4 770	3 730	-	-	*4 910	2 860	8.8 m
	3.0 m kg	-	-	-	-	-	-	*5 750	5 020	*5 180	3 590	4 730	2 680	4 650	2 640	9.1 m
	1.5 m kg	-	-	-	-	-	-	*6 730	4 730	*5 690	3 450	4 660	2 620	4 530	2 550	9.2 m
	0.0 m kg	-	-	-	-	-	-	*7 530	4 510	6 000	3 330	-	-	4 620	2 580	9.0 m
	-1.5 m kg	-	-	-	-	*10 750	6 500	*7 940	4 390	5 920	3 260	-	-	4 940	2 750	8.6 m
	-3.0 m kg	-	-	*15 280	12 110	*10 470	6 500	*7 840	4 380	5 950	3 280	-	-	5 650	3 140	7.8 m
-4.5 m kg	*16 740	*16 740	*13 000	12 410	*9 250	6 650	*6 830	4 500	-	-	-	-	*5 840	4 000	6.6 m	
Boom : 5.7m HD Arm : 2.0m ME Shoe : 600mm CWT : 5 000kg	7.5 m kg	-	-	-	-	-	-	-	-	-	-	-	-	*6 270	*6 270	4.9 m
	6.0 m kg	-	-	-	-	-	-	*6 020	5 190	-	-	-	-	*6 060	4 770	6.3 m
	4.5 m kg	-	-	-	-	*7 650	*7 650	*6 410	5 040	-	-	-	-	*6 100	3 880	7.1 m
	3.0 m kg	-	-	-	-	*9 620	7 110	*7 210	4 810	6 190	3 480	-	-	6 170	3 470	7.5 m
	1.5 m kg	-	-	-	-	-	-	*7 980	4 590	6 090	3 400	-	-	5 970	3 330	7.6 m
	0.0 m kg	-	-	-	-	*11 520	6 570	8 320	4 470	-	-	-	-	6 160	3 410	7.4 m
	-1.5 m kg	-	-	-	-	*11 130	6 600	*8 290	4 460	-	-	-	-	6 880	3 780	6.9 m
-3.0 m kg	-	-	*13 280	12 670	*9 870	6 750	-	-	-	-	-	-	*7 320	4 730	5.9 m	

Notes: 1. Machine in "Fine Mode-F" (Power Boost) for lifting capacities. 2. The above loads are in compliance with SAE J1097 and ISO 10567 Hydraulic Excavator Lifting Capacity Standards. 3. Rated loads do not exceed 87% of hydraulic lifting capacity or 75% of tipping load. 4. Rated loads marked with an asterisk (*) are limited by hydraulic capacity rather than tipping load.

LIFTING CAPACITY EC220EN

Lifting capacity at the arm end without bucket.

For lifting capacity including bucket, simply subtract actual weight of the direct fit bucket or the bucket with quick coupler from the following values.

	Lifting hook related to ground level	1.5 m		3.0 m		4.5 m		6.0 m		7.5 m		9.0 m		Max. reach			
		Along UC	Across UC	Along UC	Across UC	Along UC	Across UC	Along UC	Across UC	Along UC	Across UC	Along UC	Across UC	Along UC	Across UC	m	
Boom: 5.7m Arm: 2.5m Shoe: 600mm CWT: 4 200kg	7.5 m kg														*5 670	*5 670	5.6
	6.0 m kg							*5 500	5 130						*5 600	4 100	6.9
	4.5 m kg						*7 000	*7 000	*6 020	4 980	5 240	3 490			5 130	3 420	7.6
	3.0 m kg						*9 020	7 150	*6 910	4 740	5 140	3 410			4 670	3 090	8.0
	1.5 m kg						*10 780	6 680	6 980	4 510	5 030	3 300			4 510	2 970	8.1
	0.0 m kg						10 590	6 470	6 810	4 360	4 950	3 230			4 630	3 030	7.9
	-1.5 m kg			*10 840	*10 840	10 560	6 440	6 760	4 320						5 080	3 310	7.4
	-3.0 m kg			*14 760	12 500	*10 560	6 540	6 840	4 390						6 170	4 000	6.5
	-4.5 m kg			*11 400	*11 400	*8 140	6 820								*7 150	5 960	5.0
Boom: 5.7m Arm: 2.9m Shoe: 600mm CWT: 4 200kg	7.5 m kg							*5 180	*5 180						*4 910	*4 910	6.2
	6.0 m kg							*5 080	*5 080						*4 580	3 750	7.3
	4.5 m kg							*5 660	5 050	5 300	3 550				*4 520	3 180	8.0
	3.0 m kg						*8 440	7 290	*6 590	4 800	5 180	3 440			4 360	2 890	8.4
	1.5 m kg						*10 370	6 780	7 030	4 560	5 050	3 320			4 230	2 780	8.5
	0.0 m kg			*5 420	*5 420	10 640	6 510	6 840	4 390	4 960	3 230				4 320	2 830	8.3
	-1.5 m kg	*6 270	*6 270	*10 320	*10 320	10 560	6 430	6 760	4 310	4 920	3 210				4 680	3 060	7.8
	-3.0 m kg	*11 380	*11 380	*15 660	12 390	10 630	6 500	6 800	4 350						5 540	3 600	6.9
	-4.5 m kg			*12 740	*12 740	*9 050	6 710								*6 920	5 000	5.6
Boom: 5.7m Arm: 3.5m Shoe: 600mm CWT: 4 200kg	7.5 m kg														*4 940	3 980	7.1
	6.0 m kg									*4 650	3 690				4 740	3 180	8.1
	4.5 m kg							*4 910	*4 910	*4 800	3 620				4 160	2 770	8.8
	3.0 m kg							*5 790	4 900	*5 220	3 490	3 930	2 600	3 860	2 550	9.1	
	1.5 m kg							*6 770	4 620	5 090	3 350	3 860	2 540	3 760	2 470	9.2	
	0.0 m kg							6 870	4 410	4 960	3 230				3 820	2 500	9.0
	-1.5 m kg					10 520	6 400	6 740	4 290	4 890	3 170				4 090	2 670	8.6
	-3.0 m kg			*15 400	12 180	10 530	6 410	6 720	4 280	4 910	3 190				4 680	3 050	7.8
	-4.5 m kg	*16 740	*16 740	*13 110	12 480	*9 330	6 550	6 860	4 400						*5 890	3 900	6.6
Boom: 5.57m 2-piece Arm: 2.0m Shoe: 600mm CWT: 4 200kg	7.5 m kg						*8 600	8 040							*8 480	7 260	4.8
	6.0 m kg						*8 580	7 980	*7 470	4 960					7 160	4 710	6.2
	4.5 m kg						*9 580	7 520	7 400	4 830					5 750	3 770	7.0
	3.0 m kg						*10 890	6 890	7 120	4 590					5 140	3 340	7.4
	1.5 m kg							6 870	4 360	4 960	3 200				4 950	3 190	7.5
	0.0 m kg					10 460	6 280	6 730	4 230						5 110	3 280	7.3
	-1.5 m kg					*9 360	6 310	6 730	4 230						5 740	3 660	6.7
	-3.0 m kg					*6 690	6 500										5.7
	-3.0 m kg			*10 990	*10 990	*8 600	7 240	*6 370	4 810						*4 980	4 080	6.8
Boom: 5.57m 2-piece Arm: 2.5m Shoe: 600mm CWT: 4 200kg	7.5 m kg						*7 840	*7 840							*6 800	5 890	5.5
	6.0 m kg						*8 000	*8 000	*7 020	5 100					*6 230	4 160	6.7
	4.5 m kg			*12 730	*12 730	*9 040	7 740	*7 360	4 940						5 210	3 430	7.5
	3.0 m kg					*10 490	7 110	7 230	4 680	5 110	3 340				4 720	3 080	7.9
	1.5 m kg					10 820	6 580	6 950	4 430	4 990	3 230				4 560	2 950	8.0
	0.0 m kg					10 530	6 330	6 770	4 270	4 910	3 150				4 670	3 010	7.8
	-1.5 m kg			*11 490	*11 490	*10 080	6 310	6 720	4 220						5 150	3 300	7.3
	-3.0 m kg					*7 830	6 430	*5 670	4 330						*5 010	4 040	6.3
	-3.0 m kg														*6 130	*6 130	4.0
Boom: 5.57m 2-piece Arm: 2.9m Shoe: 600mm CWT: 4 200kg	7.5 m kg						*7 030	*7 030	*5 140	*5 140					*4 940	*4 940	6.0
	6.0 m kg						*7 080	*7 080	*6 680	5 200					*4 560	3 780	7.2
	4.5 m kg			*9 140	*9 140	*8 560	7 900	*7 090	5 030	5 280	3 490				*4 470	3 180	7.9
	3.0 m kg					*10 090	7 270	7 310	4 760	5 160	3 380				4 400	2 870	8.3
	1.5 m kg					10 960	6 700	7 010	4 490	5 020	3 250				4 260	2 760	8.4
	0.0 m kg			*5 940	*5 940	10 580	6 380	6 800	4 290	4 920	3 160				4 360	2 810	8.2
	-1.5 m kg			*10 850	*10 850	10 490	6 300	6 710	4 220	4 900	3 140				4 740	3 050	7.7
	-3.0 m kg			*10 990	*10 990	*8 600	6 380	*6 370	4 270						*4 980	3 630	6.8

Notes: 1. Machine in "Fine Mode-F" (Power Boost) for lifting capacities. 2. The above loads are in compliance with SAE J1097 and ISO 10567 Hydraulic Excavator Lifting Capacity Standards. 3. Rated loads do not exceed 87% of hydraulic lifting capacity or 75% of tipping load. 4. Rated loads marked with an asterisk (*) are limited by hydraulic capacity rather than tipping load.

Specifications

LIFTING CAPACITY EC220ENH

Lifting capacity at the arm end without bucket.

For lifting capacity including bucket, simply subtract actual weight of the direct fit bucket or the bucket with quick coupler from the following values.

	Lifting hook related to ground level	1.5 m		3.0 m		4.5 m		6.0 m		7.5 m		9.0 m		Max. reach				
		Along UC	Across UC	Along UC	Across UC	Along UC	Across UC	Along UC	Across UC	Along UC	Across UC	Along UC	Across UC	Along UC	Across UC	m		
Boom: 5.7m Arm: 2.5m Shoe: 500mm CWT: 5 000kg	7.5 m	kg														*5 670	*5 670	5.6
	6.0 m	kg						*5 500	5 440							*5 600	4 380	6.9
	4.5 m	kg					*7 000	*7 000	*6 020	5 290	*5 680	3 750				*5 690	3 670	7.6
	3.0 m	kg					*9 020	7 550	*6 910	5 050	*5 990	3 660				5 530	3 330	8.0
	1.5 m	kg					*10 780	7 090	*7 800	4 830	5 970	3 560				5 360	3 210	8.1
	0 m	kg					*11 570	6 880	8 110	4 680	5 890	3 490				5 500	3 270	7.9
	-1.5 m	kg			*10 840	*10 840	*11 480	6 860	8 060	4 640						6 040	3 570	7.4
	-3.0 m	kg			*14 760	13 020	*10 560	6 950	*7 790	4 710						*7 010	4 290	6.5
	-4.5 m	kg			*11 400	*11 400	*8 140	7 220								*7 150	6 330	5.0
Boom: 5.7m Arm: 2.9m Shoe: 500mm CWT: 5 000kg	7.5 m	kg							*5 180	*5 180						*4 910	*4 910	6.2
	6.0 m	kg						*5 080	*5 080							*4 580	4 000	7.3
	4.5 m	kg						*5 660	5 360	*5 350	3 800					*4 520	3 420	8.0
	3.0 m	kg					*8 440	7 690	*6 590	5 120	*5 750	3 700				*4 640	3 120	8.4
	1.5 m	kg					*10 370	7 190	*7 570	4 870	6 000	3 580				*4 950	3 010	8.5
	0 m	kg			*5 420	*5 420	*11 430	6 920	*8 140	4 700	5 900	3 490				5 140	3 060	8.3
	-1.5 m	kg	*6 270	*6 270	*10 320	*10 320	*11 590	6 850	8 060	4 630	5 860	3 460				5 580	3 300	7.8
	-3.0 m	kg	*11 380	*11 380	*15 660	12 910	*10 930	6 910	*8 080	4 670						6 590	3 880	6.9
	-4.5 m	kg			*12 740	*12 740	*9 050	7 120								*6 920	5 340	5.6
Boom: 5.7m Arm: 3.5m Shoe: 500mm CWT: 5 000kg	7.5 m	kg														*4 940	4 250	7.1
	6.0 m	kg								*4 650	3 940					*4 900	3 420	8.1
	4.5 m	kg							*4 910	*4 910	*4 800	3 870				4 920	2 990	8.8
	3.0 m	kg							*5 790	5 210	*5 220	3 750	4 660	2 810		4 590	2 760	9.1
	1.5 m	kg							*6 770	4 930	*5 730	3 610	4 600	2 750		4 470	2 680	9.2
	0 m	kg							*7 580	4 720	5 900	3 490				4 560	2 710	9.0
	-1.5 m	kg					*10 830	6 820	*8 010	4 610	5 830	3 430				4 870	2 890	8.6
	-3.0 m	kg			*15 400	12 700	*10 550	6 820	*7 900	4 600	5 850	3 450				5 570	3 300	7.8
	-4.5 m	kg	*16 740	*16 740	*13 110	13 000	*9 330	6 970	*6 880	4 710						*5 890	4 190	6.6
Boom: 5.57m 2-piece Arm: 2.0m Shoe: 500mm CWT: 5 000kg	7.5 m	kg					*8 600	8 410								*8 480	7 620	4.8
	6.0 m	kg					*8 580	8 350	*7 470	5 270						*7 400	5 010	6.2
	4.5 m	kg					*9 580	7 900	*7 670	5 140						6 800	4 030	7.0
	3.0 m	kg					*10 890	7 280	*8 130	4 890						6 100	3 590	7.4
	1.5 m	kg							8 180	4 670	5 900	3 450				5 900	3 440	7.5
	0 m	kg					*10 870	6 690	8 040	4 550						6 090	3 530	7.3
	-1.5 m	kg					*9 360	6 720	*7 120	4 550						*5 890	3 940	6.7
-3.0 m	kg					*6 690	*6 690										5.7	
Boom: 5.57m 2-piece Arm: 2.5m Shoe: 500mm CWT: 5 000kg	7.5 m	kg					*7 840	*7 840								*6 800	6 210	5.5
	6.0 m	kg					*8 000	*8 000	*7 020	5 400						*6 230	4 430	6.7
	4.5 m	kg			*12 730	*12 730	*9 040	8 110	*7 360	5 250						*6 120	3 680	7.5
	3.0 m	kg					*10 490	7 500	*7 930	4 990	6 060	3 590				5 600	3 310	7.9
	1.5 m	kg					*11 420	6 980	8 260	4 740	5 940	3 480				5 430	3 180	8.0
	0 m	kg					*11 250	6 740	8 080	4 580	5 860	3 410				5 570	3 250	7.8
	-1.5 m	kg			*11 490	*11 490	*10 080	6 710	*7 590	4 540						*5 700	3 560	7.3
-3.0 m	kg					*7 830	6 840	*5 670	4 640						*5 010	4 340	6.3	
Boom: 5.57m 2-piece Arm: 2.9m Shoe: 500mm CWT: 5 000kg	9.0 m	kg														*6 130	*6 130	4.0
	7.5 m	kg					*7 030	*7 030	*5 140	*5 140						*4 940	*4 940	6.0
	6.0 m	kg					*7 080	*7 080	*6 680	5 500						*4 560	4 040	7.2
	4.5 m	kg			*9 140	*9 140	*8 560	8 280	*7 090	5 330	*6 230	3 740				*4 470	3 410	7.9
	3.0 m	kg					*10 090	7 660	*7 720	5 060	6 110	3 630				*4 570	3 100	8.3
	1.5 m	kg					*11 260	7 090	*8 260	4 800	5 970	3 500				*4 850	2 990	8.4
	0 m	kg			*5 940	*5 940	*11 410	6 790	8 110	4 610	5 860	3 410				5 200	3 040	8.2
	-1.5 m	kg			*10 850	*10 850	*10 530	6 700	*7 870	4 530	*5 790	3 390				*5 490	3 290	7.7
-3.0 m	kg			*10 990	*10 990	*8 600	6 790	*6 370	4 580						*4 980	3 900	6.8	

Notes: 1. Machine in "Fine Mode-F" (Power Boost) for lifting capacities. 2. The above loads are in compliance with SAE J1097 and ISO 10567 Hydraulic Excavator Lifting Capacity Standards. 3. Rated loads do not exceed 87% of hydraulic lifting capacity or 75% of tipping load. 4. Rated loads marked with an asterisk (*) are limited by hydraulic capacity rather than tipping load.

LIFTING CAPACITY EC220ELR

Lifting capacity at the arm end without bucket.

For lifting capacity including bucket, simply subtract actual weight of the direct fit bucket or the bucket with quick coupler from the following values.

	Lifting hook related to ground level	0.0 m		1.5 m		3.0 m		4.5 m		6.0 m		7.5 m		9.0 m		
		Along UC	Across UC	Along UC	Across UC	Along UC	Across UC	Along UC	Across UC	Along UC	Across UC	Along UC	Across UC	Along UC	Across UC	
	4.5 m kg												*2 820	*2 820	*3 340	*3 340
	3.0 m kg					*6 300	*6 300	*4 590	*4 590	*3 720	*3 720	*3 210	3 070	*3 790	3 710	
	1.5 m kg					*7 880	7 320	*5 580	5 020	*4 330	3 700	*3 600	2 850	*4 210	3 410	
	0.0 m kg			*2 480	*2 480	*5 610	*5 610	*6 360	4 570	*4 860	3 410	*3 970	2 650	*4 550	3 160	
	-1.5 m kg	*2 650	*2 650	*3 360	*3 360	*5 620	*5 620	*6 860	4 290	*5 250	3 200	4 140	2 500	*4 810	2 980	
	-3.0 m kg	*3 570	*3 570	*4 340	*4 340	*6 320	6 270	*7 110	4 160	5 210	3 070	4 030	2 400	4 790	2 870	
	-4.5 m kg	*4 530	*4 530	*5 410	*5 410	*7 370	6 290	*7 120	4 120	5 150	3 020	3 980	2 350	4 740	2 830	
	-6.0 m kg	*5 560	*5 560	*6 600	*6 600	*8 740	6 410	*6 920	4 160	5 160	3 030	3 980	2 350	4 750	2 830	
	-7.5 m kg	*6 670	*6 670	*7 960	*7 960	*8 470	6 590	*6 480	4 270	*5 170	3 100	4 040	2 410	*4 710	2 900	
	-9.0 m kg			*9 560	*9 560	*7 360	6 870	*5 710	4 450	*4 560	3 240	*3 640	2 540	*4 280	3 020	
	-10.5 m kg					*5 630	*5 630	*4 390	*4 390	*3 350	*3 350			*3 520	3 230	
Boom: 8.85m Arm: 6.25m Shoe: 800mm CWT: 5 000kg	Lifting hook related to ground level	10.0 m		12 m		13.5 m		Max. reach								
		Along UC	Across UC	Along UC	Across UC	Along UC	Across UC	Along UC	Across UC	m						
	12.0 m kg							*870	*870	10.3						
	10.5 m kg							*800	*800	11.6						
	9.0 m kg			*1 450	*1 450			*760	*760	12.6						
	7.5 m kg	*2 230	*2 230	*2 060	*2 060			*740	*740	13.4						
	6.0 m kg	*2 390	*2 390	*2 330	2 070	*1 330	*1 330	*740	*740	13.9						
	4.5 m kg	*2 610	2 530	*2 470	1 980	*1 810	1 560	*750	*750	14.3						
	3.0 m kg	*2 870	2 390	*2 640	1 890	*2 160	1 500	*780	*780	14.5						
	1.5 m kg	*3 140	2 240	*2 830	1 790	2 400	1 440	*820	*820	14.6						
	0.0 m kg	*3 390	2 110	2 820	1 700	2 340	1 390	*880	*880	14.4						
	-1.5 m kg	3 330	2 000	2 740	1 630	2 300	1 350	*970	*970	14.2						
	-3.0 m kg	3 250	1 930	2 690	1 580	*1 670	1 320	*1 100	*1 100	13.7						
	-4.5 m kg	3 210	1 890	2 670	1 570			*1 280	*1 280	13.1						
-6.0 m kg	3 220	1 900	*2 410	1 590			*1 560	1 550	12.3							
-7.5 m kg	3 290	1 970					*2 030	1 830	11.2							
-9.0 m kg							*3 020	2 320	9.7							
-10.5 m kg							*3 250	*3 250	7.6							

Notes: 1. Machine in "Fine Mode-F" (Power Boost) for lifting capacities. 2. The above loads are in compliance with SAE J1097 and ISO 10567 Hydraulic Excavator Lifting Capacity Standards. 3. Rated loads do not exceed 87% of hydraulic lifting capacity or 75% of tipping load. 4. Rated loads marked with an asterisk (*) are limited by hydraulic capacity rather than tipping load.

Equipment

STANDARD EQUIPMENT

Engine

Turbocharged, 4 stroke diesel engine with water cooling, direct injection and charged air cooler that meets EU Stage V requirements

Air filter with indicator

Air intake heater

Cyclone pre-cleaner

Electric engine shut-off

Fuel filter and water separator

Fuel filler pump: 50 l/min, with automatic shut-off

Alternator, 80 A

Standard cooling system by fan clutch(40 deg. C)

Electric / Electronic control system

Contronics

Advanced mode control system

Self-diagnostic system

GSM/GPS Caretrack and 3yr-Caretrack subscription

Machine status indication

Engine speed sensing power control

Automatic idling system

One-touch power boost

Safety stop/start function

Adjustable LCD color monitor

Master electrical disconnect switch

Engine restart prevention circuit

High-capacity halogen or LED lights:

Frame-mounted 2

Boom-mounted 1

Batteries, 2 x 12 V / 140 Ah

Start motor, 24 V / 5.5 kW

Frame

Access way with handrail

Tool storage area

Punched metal anti-slip plates

Under cover (heavy duty)

Full height counterweight:

4 200 kg Long Crawler (L), Narrow Crawler (N)

5 000 kg Narrow Long Crawler (NL), Narrow Heavy (NH), Long Reach (LR)

Undercarriage

Under cover (heavy duty)

Hydraulic track adjusters

Greased and sealed track link

Track Guard

600 mm shoe with triple grousers

800 mm shoe with triple grousers (LR)

Hydraulic system

Boom hose rupture valve with overload warning device

Automatic sensing hydraulic system

Summation system

Arm priority

Swing priority

ECO mode fuel saving technology

Boom, arm and bucket regeneration valves

Swing anti-rebound valves

Boom and arm holding valves

Multi-stage filtering system

Boom cylinders (x2)

Cylinder cushioning

Cylinder contamination seals

Auxiliary hydraulic valve

Automatic two-speed travel motors

Hydraulic oil, longlife oil 46

STANDARD EQUIPMENT

Cab and interior

ROPS (ISO12117-2) certified cab

Silicon oil and rubber mounts with spring

Control lock out lever

Travel pedals and hand levers

Adjustable operator seat with heater and joystick control console

Control joysticks with 4 switches each

Heater & air-conditioner, automatic

Flexible antenna

Radio with MP3 and USB Jack with bluetooth

Cab, all-weather sound suppressed, includes:

Cup holders

Door locks

Tinted glass

Floor mat

Horn

Large storage area

Pull-up type front window

Removable lower windshield

Seat belt

Safety glass

Sun screens, front, roof, rear

Rain shield

Windshield wiper with intermittent feature

Rear view camera

Master key

Digging Equipment

Boom: monoblock 5.7 m, Long Reach 8.85 m

Arm: 2.9 m, Long Reach 6.25 m

Manual centralized lubrication

OPTIONAL EQUIPMENT

Engine

Block heater: 120 V, 240 V

Oil bath pre-cleaner

Diesel coolant heater, 5 kW

Water separator with heater

Auto engine shutdown

Fuel filler pump, 35 lpm

Tropical cooling system (50 deg. C)

Electric

Extra work lights (Halogen or LED):

Boom-mounted 1

Cab-mounted 3

Counterweight-mounted 1

Travel alarm

Anti-theft system

Rotating warning beacon

Flashing beacon, LED

Side view camera

Dig assist 2D/In-field/Steelwrist

Volvo Smart View (VSV)

Undercarriage

Full track guard

500/600/600 HD/700/800/900 mm shoe with triple grousers

700 mm shoe with double grousers

600 mm shoe with single grouser

OPTIONAL EQUIPMENT

Hydraulic system

Arm hose rupture valve
Boom float function with HRV
Boom float function without HRV
Hydraulic piping:
Work tool management system (up to 20 programmable memories)
Breaker & shear, 1 and 2 pump flow
Slope & rotator (40lpm or 60lpm)
Extra for slope & rotator
Grapple
Oil leak (drain) line
Quick coupler
Breaker & shear pressure pre-setting
Additional return filter
Volvo hydraulic quick coupler S1, S1 without hook
Volvo hydraulic quick coupler VQC-HD, S70 / VQC-HU, DR22
Hydraulic oil, biodegradable 46
Hydraulic oil, longlife oil 32, 46, 68

OPTIONAL EQUIPMENT

Cab and interior

Fabric seat without heater
Fabric seat with heater and air suspension
Control joysticks with semi-long
Control joysticks with 3 switch & 1 proportional
Opening top hatch
Falling object guard (FOG)
Frame-mounted
Cab-mounted
Cab-mounted falling object protective structure (FOPS)
Side view camera
Smoker kit (ashtray and lighter)
Safety net for front window
Sunlight protection, roof (steel)
Lower wiper with intermittent control
Cleaning air gun
Anti-vandalism kit
Specific key

Digging equipment

Boom: 5.7 m monoblock, heavy duty
Boom: 5.57 m 2 piece boom
Arm: 2.0 m, 2.5 m, 2.9 m, 3.5 m
Linkage with lifting eye

Service

Tool kit, daily maintenance
Tool kit, full scale

SELECTION OF VOLVO OPTIONAL EQUIPMENT

Auto engine shutdown**Two-piece boom****Diesel coolant heater****LED lights****Fuel fill pump****Cleaning air gun**

Not all products are available in all markets. Under our policy of continuous improvement, we reserve the right to change specifications and design without prior notice. The illustrations do not necessarily show the standard version of the machine.

VOLVO

Volvo Construction Equipment

volvo.com