

CX290B

**EXCAVATOR
TIER III CERTIFIED**

ENGINE

Model	Isuzu 6HK1YSS, Tier III certified
Type	4-stroke, turbocharged
Cylinders	6
Bore/Stroke	4.53 in x 4.92 in (115 x 125 mm)
Displacement	475 in ³ (7.8 L)
Fuel injection	Direct
Fuel injection pump	Electronic
Fuel	Diesel
Cooling	Liquid
Horsepower per SAE J1349	
Net	207 hp (154 kW) @ 1800 rpm
Maximum torque @ 1500 rpm	
Net	627 lb-ft (850 N-m)

BOOM/ARM

Boom	
Length	20 ft 2 in (6.15 m)
Boom w/arm cylinder & plumbing	5,719 lb (2603 kg)
Hoist cylinders (2)	558 lb (243 kg) ea
Total weight	6,835 lb (3089 kg)
12 ft 0 in Arm (3.66 m)	
Bare arm	2,183 lb (990 kg)
Bucket cylinder linkage & plumbing	1,102 lb (500 kg)
Total arm weight	3,285 lb (1490 kg)
10 ft 6 in Arm (3.2 m)	
Bare arm	1,896 lb (860 kg)
Bucket cylinder linkage & plumbing	1,102 lb (500 kg)
Total arm weight	2,998 lb (1360 kg)
8 ft 9 in Arm (2.66 m)	
Bare arm	1,676 lb (760 kg)
Bucket cylinder linkage & plumbing	1,102 lb (500 kg)
Total arm weight	2,778 lb (1260 kg)

UNDERCARRIAGE

Number of rollers	
Top, each track	2
Bottom, each track	9
Number of shoes	
Triple grouser – each side	50
Link pitch	7.9 in (203 mm)
Gradability	70%

HYDRAULICS

Pumps (2)	Variable displacement axial piston pumps with regulating system
Capacity –	
Maximum	2 x 64.2 gpm (243 L/min)
System relief pressure –	
Standard	4,975 psi (34.3 MPa)
Power Boost	5,410 psi (37.3 MPa)
Control valves –	
4-spool section for right track travel, boom, bucket, and arm acceleration	
5-spool section for left track travel, auxiliary, swing, arm, and boom acceleration	
Boom and arm anti-drift valves	
Pilot control hydraulic system –	
Pump (1)	Gear design
Maximum capacity	7.1 gpm (27 L/min)
Relief pressure	566 psi (3.9 MPa)
Swing –	
Motor (1)	Fixed displacement axial piston design
Speed	0-10.2 rpm
Brake	Spring-applied mechanical disk
Travel –	
Motor (1)	Two-speed axial piston design
Final drive	Planetary gear reduction
Drawbar pull	52,425 (233 kN)
Travel Speeds –	
Auto shift high to low	
Forward/Reverse	
Low	2.0 mph (3.2 km/h)
High	3.5 mph (5.6 km/h)
Travel control valve –	Dual stage relief and counter-balance design

HYDRAULIC CYLINDERS

Boom cylinders (2) –	
Bore diameter	5.5 in (140 mm)
Rod diameter	3.7 in (95 mm)
Stroke	53.9 in (1369 mm)
Arm cylinder (1) –	
Bore diameter	5.9 in (150 mm)
Rod diameter	4.1 in (105 mm)
Stroke	61.7 in (1569 mm)
Bucket cylinder (1) –	
Bore diameter	5.3 in (135 mm)
Rod diameter	3.5 in (90 mm)
Stroke	42.4 in (1078 mm)

ELECTRICAL

Voltage	24 volts, negative ground
Alternator	50 amp
Batteries (2)	Low-maintenance 128 Ah (5 hr rate)

SERVICE CAPACITIES

Hydraulic tank	
Refill capacity	38.8 gal (147 L)
Total system	79.3 gal (300 L)
Final drive (per side)	9.6 qt (9.1 L)
Swing drive	6.3 qt (6.0 L)
Engine	
w/filter change	40.2 qt (38 L)
Fuel	118.9 gal (450 L)
Radiator	30.6 qt (29.0 L)

OPERATING WEIGHT

With 10 ft 6 in (3.2 m) arm, 31.5 in (800 mm) track shoes, 1,777 lb (806 kg) bucket, 165 lb (75 kg) operator, full fuel and standard equipment 65,697 lb (29 800 kg)

LIFT CAPACITIES

10 ft 6 in (3.20 m) Arm Lift capacities calculated using a 1,778 lb (806 kg) bucket, 11,927 lb (5410 kg) counterweight.

Load (Lift Point) Height	10 ft (3.05 m)		15 ft (4.57 m)		20 ft (6.1 m)		25 ft (7.62 m)		30 ft (9.14 m)		MAXIMUM REACH			
	END	SIDE	END	SIDE	END	SIDE	END	SIDE	END	SIDE	@	END	SIDE	
+30 ft (9.14 m)												24 ft 0 in (7.31 m)	8,450 lb* (3833 kg)*	8,450 lb* (3833 kg)*
+25 ft (7.62 m)												28 ft 6 in (8.68 m)	7,850 lb* (3561 kg)*	7,850 lb* (3561 kg)*
+20 ft (6.1 m)							13,300 lb* (6033 kg)*	12,150 lb (5511 kg)				31 ft 5 in (9.57 m)	7,600 lb* (3447 kg)*	7,600 lb* (3447 kg)*
+15 ft (4.57 m)					17,350 lb* (7870 kg)*	16,950 lb* (7688 kg)*	15,700 lb* (7121 kg)*	11,850 lb (5375 kg)	9,600 lb* (4354 kg)*	8,500 lb (3856 kg)		33 ft 1 in (10.08 m)	7,700 lb* (3493 kg)*	7,150 lb (3243 kg)
+10 ft (3.05 m)	39,200 lb* (17 781 kg)*	39,200 lb* (17 781 kg)*	26,200 lb* (11 884 kg)*	25,500 lb* (11 567 kg)*	20,300 lb* (9208 kg)*	16,250 lb (7371 kg)	17,200 lb* (7802 kg)*	11,350 lb (5148 kg)	13,000 lb (5897 kg)	8,300 lb (3765 kg)		33 ft 11 in (10.33 m)	7,950 lb* (3606 kg)*	6,650 lb (3016 kg)
+5 ft (1.52 m)	18,200 lb* (8255 kg)*	18,200 lb* (8255 kg)*	33,350 lb* (15 127 kg)*	23,600 lb (10 705 kg)	23,200 lb* (10 523 kg)*	15,300 lb (6940 kg)	17,050 lb (7734 kg)	10,850 lb (4921 kg)	12,700 lb (5761 kg)	8,050 lb (3651 kg)		33 ft 10 in (10.31 m)	8,500 lb* (3856 kg)*	6,550 lb (2971 kg)
Ground-line	19,800 lb* (8981 kg)*	19,800 lb* (8981 kg)*	35,700 lb* (16 193 kg)*	22,300 lb (10 115 kg)	23,600 lb (10 705 kg)	14,500 lb (6577 kg)	16,600 lb (7530 kg)	10,400 lb (4717 kg)	12,450 lb (5647 kg)	7,800 lb (3538 kg)		32 ft 11 in (10.03 m)	9,350 lb* (4241 kg)*	6,750 lb (3062 kg)
-5 ft (-1.52 m)	25,600 lb* (11 612 kg)*	25,600 lb* (11 612 kg)*	35,750 lb* (16 216 kg)*	21,850 lb (9911 kg)	23,100 lb (10 478 kg)	14,100 lb (6396 kg)	16,300 lb (7394 kg)	10,100 lb (4581 kg)	12,350 lb (5602 kg)	7,700 lb (3493 kg)		31 ft 0 in (9.44 m)	10,750 lb* (4876 kg)*	7,400 lb (3357 kg)
-10 ft (-3.05 m)	34,000 lb* (15 422 kg)*	34,000 lb* (15 422 kg)*	34,100 lb* (15 468 kg)*	21,950 lb (9956 kg)	23,050 lb (10 455 kg)	14,050 lb (6373 kg)	16,250 lb (7371 kg)	10,050 lb (4559 kg)				27 ft 10 in (8.48 m)	13,200 lb* (5987 kg)*	8,800 lb (3992 kg)
-15 ft (-4.57 m)	42,000 lb* (19 051 kg)*	42,000 lb* (19 051 kg)*	29,850 lb* (13 540 kg)*	22,350 lb (10 138 kg)	22,150 lb* (10 047 kg)*	14,250 lb (6464 kg)						22 ft 11 in (6.98 m)	11,700 lb* (5307 kg)*	11,700 lb* (5307 kg)*
-20 ft (-6.1 m)	29,100 lb* (13 200 kg)*	29,100 lb* (13 200 kg)*	21,100 lb* (9571 kg)*	21,100 lb* (9571 kg)*										

8 ft 9 in (2.67 m) Arm Lift capacities calculated using a 1,914 lb (868 kg) bucket, 11,927 lb (5410 kg) counterweight.

Load (Lift Point) Height	10 ft (3.05 m)		15 ft (4.57 m)		20 ft (6.1 m)		25 ft (7.62 m)		30 ft (9.14 m)		MAXIMUM REACH			
	END	SIDE	END	SIDE	END	SIDE	END	SIDE	END	SIDE	@	END	SIDE	
+25 (7.62 m)												26 ft 8 in (8.12 m)	9,832 lb* (4460 kg)*	9,832 lb* (4460 kg)*
+20 ft (6.1 m)							14,450 lb* (6554 kg)*	11,850 lb (5375 kg)				29 ft 9 in (9.06 m)	9,532 lb* (4323 kg)*	8,648 lb (3923 kg)
+15 ft (4.57 m)					18,750 lb* (8505 kg)*	16,900 lb (7666 kg)	16,700 lb* (7575 kg)*	11,650 lb (5284 kg)				31 ft 7 in (9.62 m)	9,582 lb* (4346 kg)*	7,598 lb (3446 kg)
+10 ft (3.05 m)			29,150 lb* (13 222 kg)*	25,000 lb (11 340 kg)	21,500 lb* (9752 kg)*	15,950 lb (7235 kg)	17,450 lb (7915 kg)	11,200 lb (5080 kg)	12,400 lb* (5625 kg)*	8,200 lb (3719 kg)		32 ft 5 in (9.88 m)	9,932 lb* (4505 kg)*	7,048 lb (3197 kg)
+5 ft (1.52 m)			33,500 lb* (15 195 kg)*	23,100 lb (10 478 kg)	24,100 lb* (10932 kg)*	15,050 lb (6827 kg)	16,950 lb (7688 kg)	10,700 lb (4853 kg)	12,650 lb (5738 kg)	8,000 lb (3629 kg)		32 ft 4 in (9.85 m)	10,532 lb* (4777 kg)*	7,050 lb (3198 kg)
Ground-line	18,450 lb* (8369 kg)*	18,450 lb* (8369 kg)*	35,750 lb* (16 216 kg)*	22,050 lb (10 002 kg)	23,450 lb (10637 kg)	14,400 lb (6532 kg)	16,500 lb (7484 kg)	10,350 lb (4695 kg)	12,450 lb (5647 kg)	7,800 lb (3538 kg)		31 ft 4 in (9.55 m)	11,548 lb (5238 kg)	7,300 lb (3311 kg)
-5 ft (-1.52 m)	26,350 lb* (11 952 kg)*	26,350 lb* (11 952 kg)*	35,400 lb* (16 057 kg)*	21,950 lb (9956 kg)	23,100 lb (10478 kg)	14,100 lb (6396 kg)	16,300 lb (7394 kg)	10,150 lb (4604 kg)				29 ft 4 in (8.94 m)	12,798 lb (5805 kg)	8,100 lb (3674 kg)
-10 ft (-3.05 m)	37,500 lb* (17 010 kg)*	37,500 lb* (17 010 kg)*	32,900 lb* (14 923 kg)*	22,150 lb (10 047 kg)	23,150 lb (10501 kg)	14,150 lb (6418 kg)	16,350 lb (7416 kg)	10,200 lb (4627 kg)				26 ft 0 in (7.92 m)	14,532 lb* (6591 kg)*	9,900 lb (4491 kg)
-15 ft (-4.57 m)	37,550 lb* (17 032 kg)*	37,550 lb* (17 032 kg)*	27,450 lb* (12 451 kg)*	22,700 lb (10 297 kg)	20,200 lb* (9163 kg)*	14,500 lb (6577 kg)								

12 ft (3.66 m) Arm Lift capacities calculated using a 1,741 lb (790 kg) bucket, 11,927 lb (5410 kg) counterweight.

Load (Lift Point) Height	10 ft (3.05 m)		15 ft (4.57 m)		20 ft (6.1 m)		25 ft (7.62 m)		30 ft (9.14 m)		MAXIMUM REACH			
	END	SIDE	END	SIDE	END	SIDE	END	SIDE	END	SIDE	@	END	SIDE	
+30 ft (9.14 m)												26 ft 4 in (8.02 m)	7,100 lb* (3221 kg)*	7,100 lb* (3221 kg)*
+25 ft (7.62 m)							9,650 lb* (4377 kg)*	9,650 lb* (4377 kg)*				30 ft 5 in (9.27 m)	6,550 lb* (2971 kg)*	6,550 lb* (2971 kg)*
+20 ft (6.1 m)							12,400 lb* (5625 kg)*	12,200 lb* (5534 kg)*				33 ft 2 in (10.10 m)	6,350 lb* (2880 kg)*	6,350 lb* (2880 kg)*
+15 ft (4.57 m)							14,600 lb* (6622 kg)*	11,950 lb (5420 kg)	10,950 lb* (4967 kg)*	8,600 lb (3901 kg)		34 ft 9 in (10.59 m)	6,400 lb* (2903 kg)*	6,400 lb* (2903 kg)*
+10 ft (3.05 m)	19,100 lb* (8664 kg)*	19,100 lb* (8664 kg)*	24,000 lb* (10 886 kg)*	24,000 lb* (10 886 kg)*	18,900 lb* (8573 kg)*	16,500 lb (7484 kg)	16,200 lb* (7348 kg)*	11,450 lb (5194 kg)	13,050 lb (5919 kg)	8,350 lb (3787 kg)		35 ft 6 in (10.82 m)	6,600 lb* (2994 kg)*	6,100 lb (2767 kg)
+5 ft (1.52 m)	23,950 lb* (10 864 kg)*	23,950 lb* (10 864 kg)*	31,050 lb* (14 084 kg)*	24,000 lb (10 886 kg)	22,050 lb* (10 002 kg)*	15,400 lb (6985 kg)	17,100 lb (7756 kg)	10,850 lb (4921 kg)	12,700 lb (5761 kg)	8,000 lb (3629 kg)		35 ft 5 in (10.79 m)	7,000 lb* (3175 kg)*	5,950 lb (2699 kg)
Ground-line	20,150 lb* (9140 kg)*	20,150 lb* (9140 kg)*	34,900 lb* (15 830 kg)*	22,350 lb (10 138 kg)	23,650 lb (10 727 kg)	14,500 lb (6577 kg)	16,550 lb (7507 kg)	10,350 lb (4695 kg)	12,400 lb (5625 kg)	7,750 lb (3515 kg)		34 ft 6 in (10.51 m)	7,700 lb* (3493 kg)*	6,100 lb (2767 kg)
-5 ft (-1.52 m)	23,950 lb* (10 864 kg)*	23,950 lb* (10 864 kg)*	35,600 lb* (16 148 kg)*	21,650 lb (9820 kg)	23,000 lb (10 433 kg)	14,000 lb (6350 kg)	16,150 lb (7326 kg)	10,000 lb (4536 kg)	12,200 lb (5534 kg)	7,550 lb (3425 kg)		32 ft 9 in (9.98 m)	8,750 lb* (3969 kg)*	6,650 lb (3016 kg)
-10 ft (-3.05 m)	30,600 lb* (13 880 kg)*	30,600 lb* (13 880 kg)*	34,600 lb* (15 694 kg)*	21,600 lb (9798 kg)	22,800 lb (10 342 kg)	13,800 lb (6260 kg)	16,050 lb (7280 kg)	9,900 lb (4491 kg)	12,150 lb* (5511 kg)*	7,550 lb (3425 kg)		29 ft 10 in (9.09 m)	10,550 lb* (4785 kg)*	7,750 lb (3515 kg)
-15 ft (-4.57 m)	42,600 lb* (19 323 kg)*	42,600 lb* (19 323 kg)*	31,300 lb* (14 197 kg)*	21,950 lb (9956 kg)	22,900 lb (10 387 kg)	13,950 lb (6328 kg)	16,200 lb (7348 kg)	10,000 lb (4536 kg)				25 ft 5 in (7.74 m)	12,950 lb* (5874 kg)*	10,200 lb (4627 kg)
-20 ft (-6.1 m)	34,100 lb* (15 468 kg)*	34,100 lb* (15 468 kg)*	24,350 lb* (11 045 kg)*	22,450 lb (10 183 kg)	17,250 lb* (7824 kg)*	14,500 lb (6577 kg)								

*Lift capacities do not exceed 75% of the minimum tipping load or 87% of the hydraulic lift capacity. Capacities that are marked with an asterisk are hydraulic limited.

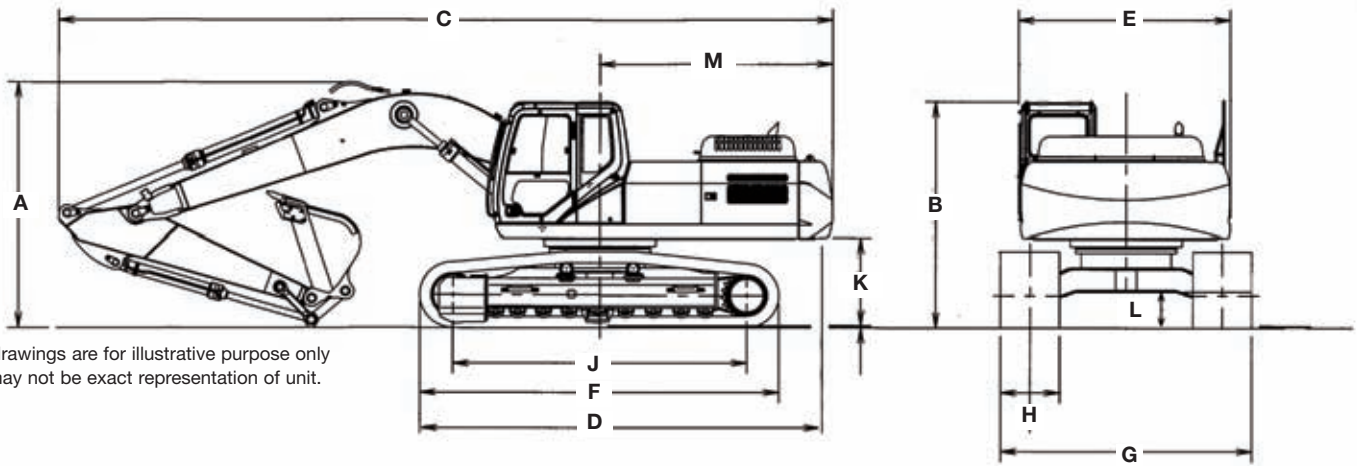

Line drawings are for illustrative purpose only and may not be exact representation of unit.

DIMENSIONS

	12 ft 0 in (3.66 m) Arm	10 ft 5 in (3.18 m) Arm	8 ft 8 in (2.65 m) Arm
A. Overall height	11 ft 4 in (3.46 m)	10 ft 8 in (3.26 m)	10 ft 11 in (3.34 m)
B. Cab height	10 ft 1 in (3.07 m)	10 ft 1 in (3.07 m)	10 ft 1 in (3.07 m)
C. Overall length	34 ft 5 in (10.47 m)	34 ft 4 in (10.45 m)	34 ft 5 in (10.48 m)
D. w/o attachment	18 ft 4 in (5.59 m)	18 ft 4 in (5.59 m)	18 ft 4 in (5.59 m)
E. Width of upperstructure	9 ft 5 in (2.87 m)	9 ft 5 in (2.87 m)	9 ft 5 in (2.87 m)
F. Track overall length	15 ft 11 in (4.85 m)	15 ft 11 in (4.85 m)	15 ft 11 in (4.85 m)
G. Track overall width w/31.5 in (800 mm) shoes	11 ft 2 in (3.40 m)	11 ft 2 in (3.40 m)	11 ft 2 in (3.40 m)
H. Track shoe width	31.5 in (800 mm)	31.5 in (800 mm)	31.5 in (800 mm)
J. Center to center (idler to sprocket)	13 ft 1 in (3.98 m)	13 ft 1 in (3.98 m)	13 ft 1 in (3.98 m)
K. Upperstructure ground clearance	3 ft 11 in (1.19 m)	3 ft 11 in (1.19 m)	3 ft 11 in (1.19 m)
L. Minimum ground clearance	1 ft 7 in (0.470 m)	1 ft 7 in (0.470 m)	1 ft 7 in (0.470 m)
M. Tail swing radius	10 ft 4 in (3.16 m)	10 ft 4 in (3.16 m)	10 ft 4 in (3.16 m)
Working weight*	65,984 lb (29 930 kg)	65,697 lb (29 800 kg)	65,477 lb (29 700 kg)
Ground pressure	6.2 psi (43.0 kPa)	6.1 psi (42.0 kPa)	6.1 psi (42.0 kPa)

*With 31.5 in (800 mm) track shoe, 1,777 lb (806 kg) bucket, 165 lb (75 kg) operator, full fuel and standard equipment.

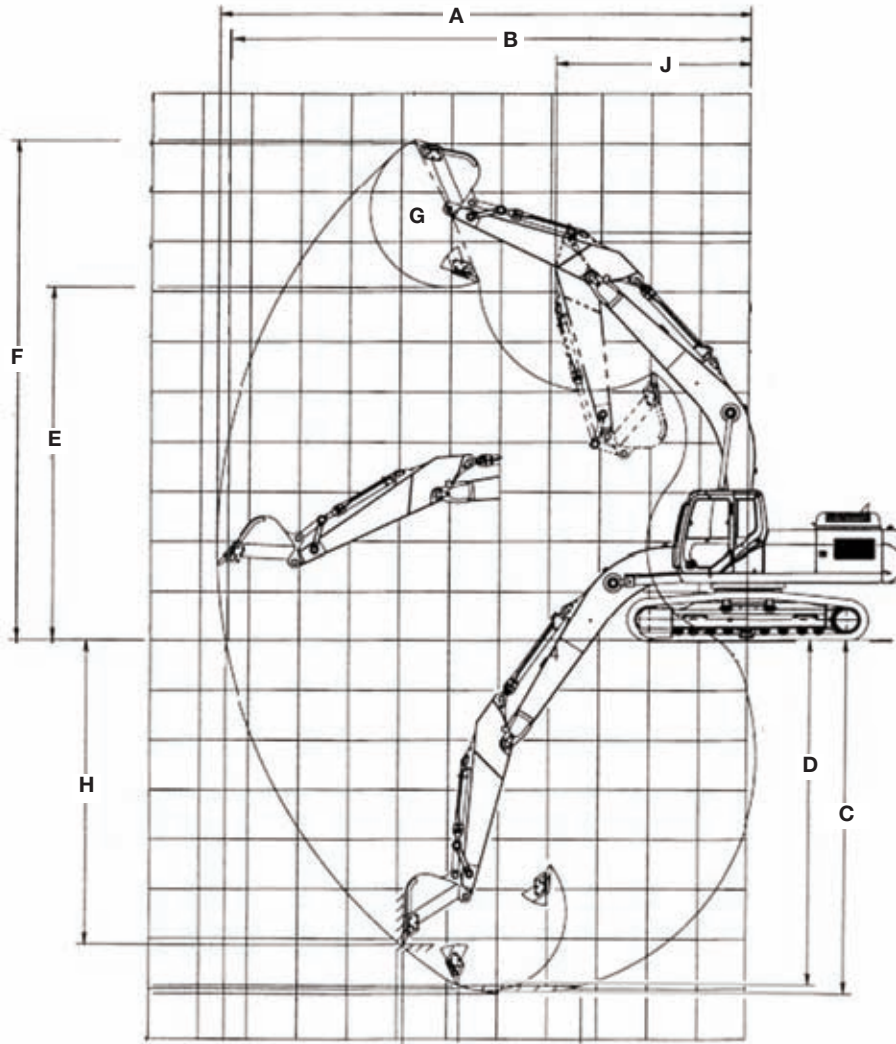

PERFORMANCE SPECS

	12 ft 0 in (3.66 m) Arm	10 ft 5 in (3.18 m) Arm	8 ft 8 in (2.65 m) Arm
A. Maximum dig radius	36 ft 7 in (11.16 m)	35 ft 0 in (10.67 m)	33 ft 6 in (10.22 m)
B. Dig radius at groundline	36 ft 1 in (10.99 m)	34 ft 5 in (10.50 m)	32 ft 11 in (10.04 m)
C. Maximum dig depth	24 ft 11 in (7.58 m)	23 ft 4 in (7.10 m)	21 ft 7 in (6.57 m)
D. Dig depth – 8 ft 0 in (2.44 m) level bottom	24 ft 5 in (7.44 m)	22 ft 9 in (6.94 m)	21 ft 0 in (6.39 m)
E. Dump height	24 ft 2 in (7.39 m)	23 ft 3 in (7.09 m)	22 ft 10 in (6.94 m)
F. Overall reach height	34 ft 1 in (10.39 m)	33 ft 0 in (10.06 m)	32 ft 7 in (9.93 m)
G. Bucket rotation	176°	176°	176°
H. Vertical straight wall dig depth	22 ft 0 in (6.72 m)	20 ft 1 in (6.12 m)	18 ft 11 in (5.76 m)
J. Minimum swing radius	13 ft 1 in (4.00 m)	12 ft 11 in (3.92 m)	13 ft 1 in (4.00 m)
Arm digging force			
Standard	24,684 lb (109.8 kN)	27,337 lb (121.6 kN)	31,518 lb (140.2 kN)
Power Boost	26,685 lb (118.7 kN)	29,765 lb (132.4 kN)	34,396 lb (153.0 kN)
Bucket digging force			
Standard	39,252 lb (174.6 kN)	39,252 lb (174.6 kN)	39,252 lb (174.6 kN)
Power Boost	42,759 lb (190.2 kN)	42,754 lb (190.2 kN)	42,759 lb (190.2 kN)

STANDARD EQUIPMENT

OPERATOR'S COMPARTMENT

Sliding front window - storable
 LCD monitor display
 Skylight
 Cab with Isomount® system
 Adjustable deluxe seat with 3 in (76 mm) retractable seat belt
 Safety glass - all windows
 Climate Control System
 AM/FM Radio w/auto tuner
 Windshield wiper w/washer
 Anti-theft device
 Dome light
 Single pedal travel

ENGINE

Case 6HK1YSS turbocharged diesel
 Tier III certified
 Warm up mode
 Selectable one touch or auto accelerator/decelerator
 Dial type throttle control
 Emergency stop
 Auto engine derate
 Auto and one touch idle

OPTIONAL EQUIPMENT

UPPERSTRUCTURE

Arm: 12 ft 0 in, 10 ft 6 in or 8 ft 9 in (3.66 m, 3.2 m or 2.7 m)
 FOPS guard level 2
 Front screen
 Front grill
 Sun visor
 Rain deflector
 See through skylight

ELECTRICAL

Batteries (2)
 Electronic Systems Monitor
 Boom worklight
 Turntable worklight

HYDRAULICS

ISO pattern pilot controls
 Work mode selector: SP, H & Auto
 Power Boost - automatic
 2 Variable flow piston pumps
 Auxiliary attachment mode
 Neutral pump destroke
 Auxiliary hydraulic valve
 Boom and arm anti-drift valves
 Attachment cushion control for boom and arm
 100% return oil filtration

UNDERCARRIAGE

Shoes: 31.5 in (800 mm) 3-bar, 47 per side
 Track length: 15 ft 11 in (4.85 m)
 Track gauge: 8 ft 6 in (2.59 m)
 Sealed and lubed track

TRACK DRIVE

2-speed hydrostatic travel
 Straight tracking travel priority
 Disc-type parking brakes

UPPERSTRUCTURE

Boom: 20 ft 2 in (6.15 m) one piece
 Hammer adaptable
 Swing brake

OTHER

Counterweight: 11,927 lb (5410 kg)
 Single key lockup

HYDRAULICS

Auxiliary hydraulics
 Single acting, one pump (includes heavy-duty bucket linkage)
 Double acting, single or dual pump (includes heavy-duty bucket linkage)
 Double acting general purpose for use with thumb kit
 Control pattern selector valve

OTHER

Air suspension seat
 Load holding control devices
 Cylinder mounted
 Esco* hydraulic coupler

BUCKETS

Application	Width	SAE Heaped Capacity
General purpose	30 in to 54 in (0.76 to 1.37 m)	0.79 yd ³ to 2.15 yd ³ (0.60 m ³ to 1.64 m ³)
Heavy-duty plate lip	24 in to 54 in (0.61 to 1.37 m)	0.79 yd ³ to 2.15 yd ³ (0.60 m ³ to 1.64 m ³)
Extreme-duty rate lip	24 in to 48 in (0.61 to 1.22 m)	0.69 yd ³ to 1.67 yd ³ (0.53 m ³ to 1.28 m ³)
Ditching	60 in to 66 in (1.52 to 1.67 m)	1.30 yd ³ to 1.45 yd ³ (0.99 m ³ to 1.11 m ³)

This page intentionally left blank.

NOTE: All specifications are stated in accordance with SAE Standards or Recommended Practices, where applicable.

NOTE: All engines meet current EPA emissions requirements.

IMPORTANT: Case Construction Equipment Inc. reserves the right to change these specifications without notice and without incurring any obligation relating to such change. Case Construction Equipment Inc. does not warrant the safety or reliability of attachments from other manufacturers.

Case is a registered trademark of CNH America LLC. Any trademarks referred to herein, in association with goods and/or services of companies other than CNH America LLC, are the property of those respective companies.



www.casece.com