

Engine	Cummins 6BTAA5.9-C170
Gross Power	125 kW (170 hp) @ 2,200 rpm
Net Power	112.5 kW (153 hp) @ 2,200 rpm
Operating Weight	13,700 kg
Standard Bucket Size	2.3 m ³
Standard Breakout Force	125 kN
Standard Dump Clearance	2,880 mm

842

WHEEL LOADER

 **LIUGONG**



TOUGH WORLD. TOUGH EQUIPMENT.

842 SPECIFICATIONS >>>

ENGINE

Emission Regulation	Tier 2 / Stage II
Make	Cummins
Model	6BTAA5.9-C170
Gross Power	125 kW (170 hp) @ 2,200 rpm
Net Power	112.5 kW (153 hp) @ 2,200 rpm
Peak Torque	750 N · m @ 1,400 rpm
Displacement	5.9 L
Number of Cylinders	6
Aspiration	Turbocharged & Air-to-air intercooled

TRANSMISSION

Transmission Type	Countershaft, power shift
Torque Converter	Single stage, three elements
Maximum Travel Speed, fwd	41.5 km/h
Maximum Travel Speed, rev	26.3 km/h
Number of Speeds, fwd	4
Number of Speeds, rev	3

AXLES

Differential Front Type	Conventional
Differential Rear Type	Conventional
Axle Oscillation	±12°

STEERING

Steering Configuration	Articulated
Steering Relief Pressure	15 Mpa

BRAKES

Service Brake Type	Caliper disc brake
Service Brake Actuation	Air over hydraulic
Parking Brake Type	Manual pneumatic control
Parking Brake Actuation	Air

HYDRAULIC SYSTEM

Main Pump Type	Gear
Main Relief Pressure	18 MPa
Raise	5.5 s
Dump Time	1.2 s
Float Down Time	3.7 s
Fastest Total Cycle Time	10.4 s

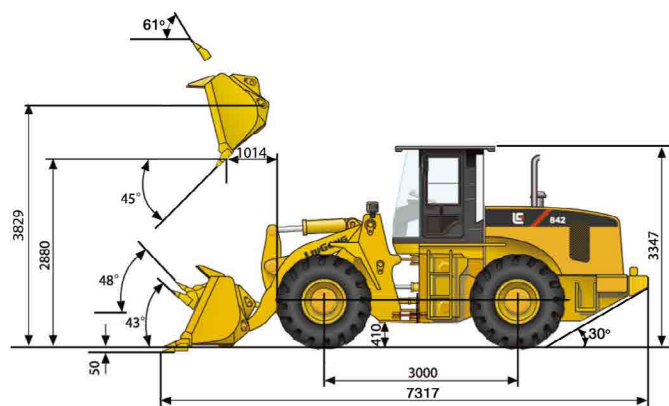

LOADER ARM PERFORMANCE

Tipping Load - Straight	9,898 kg
Tipping Load - Full Turn	8,571 kg
Bucket Breakout Force	125 kN
Maximum Dump Angle at Full Height	45°
Dump Clearance at Full Height Discharge	2,880 mm
Dump Reach at Full Height Discharge	1,014 mm
Maximum Hinge Pin Height	3,829 mm
Maximum Digging Depth, Bucket Level	50 mm
Bucket Rollback at Ground Level	43°
Bucket Rollback at Carry	48°
Bucket Rollback at Maximum Height	61°

BUCKET PERFORMANCE

Reference Bucket	2.3 m ³
------------------	--------------------

DIMENSIONS

Length with Bucket Down	7,317 mm
Width Over Tires	2,470 mm
Wheelbase	3,000 mm
Wheel Tread	1,950 mm
Ground Clearance	410 mm
Turn Angle, Either Side	38°
Rear Angle of Departure	30°
Turning Radius, Outside of Tire	5,591 mm
Turning Radius, Center of Tire	5,331 mm
Turning Radius, Bucket Carry	6,406 mm

TIRES

Tire Size	20.5 - 25
-----------	-----------

OPERATING WEIGHTS

Operating Weight	13,700 kg
------------------	-----------

SERVICE CAPACITY

Fuel Tank	254 L
Engine Oil	17 L
Cooling System	55 L
Hydraulic Reservoir	230 L
Transmission and Torque Converter	45 L
Axle, Front	28 L
Axle, Rear	32 L

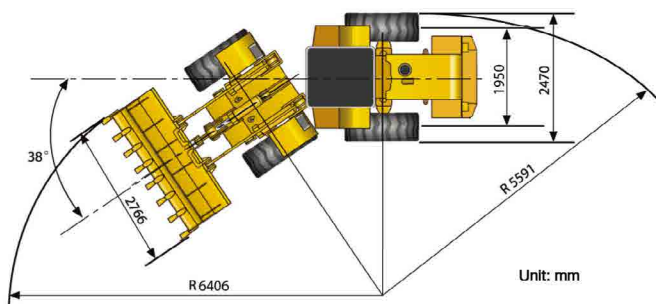

Guangxi Liugong Machinery Co., Ltd.

No. 1 Liutai Road, Liuzhou, Guangxi 545007, PR China
 T: +86 772 3886124 E: overseas@liugong.com
 www.liugong.com

Specifications and designs are subject to change without notice. Machines shown may include optional equipment.

05/2014 Designed by LiuGong