

Specification sheet

CF 370

FAN 6X2 Rigid, Low Deck

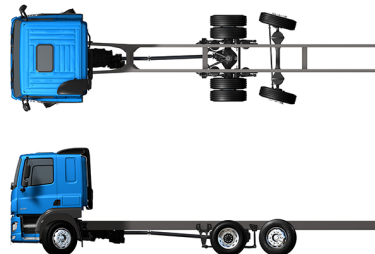

ENGINES

- CF 370 MX-11 (270 kW / 367 hp)
- CF 410 MX-11 (300 kW / 408 hp)
- CF 450 MX-11 (330 kW / 449 hp)
- CF 430 MX-13 (315 kW / 428 hp)
- CF 480 MX-13 (355 kW / 483 hp)
- CF 530 MX-13 (390 kW / 530 hp)

GVM¹⁾

26000 kg

Max. front 7500 kg

Max. rear 19000 kg

GCM²⁾

40000 kg

CAB EXTERIOR

Sleeper Cab with galvanised steel bumper, tinted glass and electric window openers. Main mirrors and wide angle mirrors electrically heated. Cab width 2300 mm.; LED daytime running lights; Electrically adjustable mirrors; Front view mirror.

Optional

01899 Day Cab	09983 Fog lights
01137 Space Cab	09984 Fog lights and cornering lights
01226 Cab suspension air	06593 Skylights
01174 External sun visor green translucent	06628 One hazard beacon light at co-driver side
00847 Air horns, single set	06627 One hazard beacon light at driver side
09006 Air horns, double set	06629 Two hazard beacon lights
08020 LED head lights	

AERODYNAMICS

Optional

06776 Adjustable roof air deflector	04906 Side collars
--	---------------------------

COLOURS

Cab colour H3279 Brilliant White; Head lamp panel and bumper: Brilliant White; Chassis colour grey..

Optional

06485 Head lamp panel and bumper: cab colour	09933 Head lamp panel and bumper: Stone Grey
---	---

CAB INTERIOR

Cab interior trim colour Dark Sand; Cab interior decoration Black Rock; Driver seat: Comfort Air; Co-driver seat: basic; Automatic Temperature Control and airco; Roof hatch aluminium, manual control; Pollen filter.

Optional

09271 Steering wheel, leather, colour black	07746 Co-driver seat: Super Air
07240 Steering wheel, leather, Exclusive	07748 Co-driver seat: Xtra Leather Air
07152 Cab interior trim colour Exclusive	00967 Seat belts red
07592 Cab interior decoration Argenta	02117 Third seat
07591 Cab interior decoration Rustica	06539 Refrigerator
07733 Driver seat: Luxury Air	31364 Without feature: Lower bunk mattress
07736 Driver seat: Super Air	06784 Lower bunk mattress Xtra Comfort
07737 Driver seat: Xtra Leather Air	06676 PL light in cab ceiling
07741 Co-driver seat: Comfort Air	06970 Automatic Cab Climate Control
07743 Co-driver seat: Luxury Air	

COMMUNICATION AND DRIVING MANAGEMENT

Tachograph digital, Stoneridge 1C; Speed limiter setting 85 km/h; Eco off 90 km/h; Antennas: AM/FM, 2x GSM, GPS; Adaptive Cruise Control with FCW and AEBs-CM2.

Optional

09681 Preparation for Maut	01100 Truck Navigation Radio, 6 speakers
08450 Luxury speaker system with 6 speakers	07261 TruckPhone
07117 Radio/USB player, 2 speakers	06991 Predictive Cruise Control

SAFETY AND SECURITY

Lane Departure Warning System; Vehicle Stability Control (VSC); Basic engine immobiliser system.

Optional

08631 Air bag (driver) and 2 seat belt tensioners	09827 Side camera system
09828 Front camera system	01725 Reverse warning

SUSPENSION AND AXLES

Front axle load 8.00 t; Rear: 11.50 + 7.50 t, air suspension, SR1344.

Optional

04588 Rear axle SR1347	08191 Axle load monitoring
-------------------------------	-----------------------------------

WHEELS AND TYRES

Front axle 1: 315/60R22.5; Rear axle 1: 315/60R22.5; Rear axle 2: 315/60R22.5; Disc wheels steel, silvergrey; Wheel protection rings silvergrey.

Optional

16152 Tyre makes and types

DRIVELINE

Engine MX-11, multi torque 6 cylinder diesel engine, 10.8 litres. Output 270 kW (367 hp) at 1600 rpm. Maximum torque 1900 Nm at 900-1125 rpm.; Exhaust emission Euro 6; Engine idle shutdown, 5 minutes; Automated gearbox, TraXon, 12 speeds; Gearbox ratio 16.69-1.00; Rear axle ratio 2.05.

Optional

04523 Manual gearbox, 16 speeds	07103 Automated gearbox, TraXon, 16 speeds
--	---

BRAKE SYSTEM

Exhaust brake; Ventilated disc brakes front and rear. Dual circuit air system with electronic control (EBS). Twin cylinder air compressor with heated dryer and economy mode..

Optional

09921 MX Engine Brake	02715 ZF Intarder
------------------------------	--------------------------

CHASSIS

Wheelbase 4.60 m / rear overhang 2.75 m; Side member height 260 mm; Standard component location; Exhaust pipe horizontal, low; Aluminium fuel tank 450 l, height 505 mm; Spray suppression; Front underrun protection (FUP); Tank for AdBlue® 45 l, left-hand side chassis.

Optional

07071 Spare wheel carrier right-hand side	03323 Rear light with LEDs
--	-----------------------------------

DRAWBAR AND TRAILER EQUIPMENT

D-value cross member D=13.7; Pneumatic trailer connection C-type; Electric connection 24 V / 2x7 pins.

Optional

07033 Trailer coupling Ringfeder D=13.7	08027 Trailer coupling Rockinger D=20.0
07034 Trailer coupling Ringfeder D=20.0	04624 Closing member
08026 Trailer coupling Rockinger D=13.0	07032 D-value cross member D=20

BODIES AND PREPARATIONS FOR BODYING

Application connector on the cab front.

Optional

- 04331** Appl connector including air control prep **02597** Application connector for tail lift control
- 06692** Application connector on the chassis

POWER TAKE-OFF (PTO)

Optional

- 16148** PTO types and positions

ELECTRICAL POWER SUPPLY

Alternator 120 A, batteries 2x 175 Ah..

Optional

- 08775** Alternator 150 A **07671** Batteries 2x210Ah AGM C-type
- 01257** Batteries 2x140Ah **06440** Batteries 2x230Ah

GVM AND GCM

Chassis weight related technical GVM max 27000 kg; Driveline related max GCM 40000 kg class 3.

Optional

- 00200** Driveline related max GCM 38000 kg class 2 **03675** Driveline related max GCM 50000 kg class 3
- 03673** Driveline related max GCM 44000 kg class 2

APPLICATION CONDITIONS

Air intake on the cab roof.

Optional

- 08400** Silent mode **09961** Cyclonic air intake behind the cab

SERVICE AND MAINTENANCE

Standard Warranty takes care of 1 year complete vehicle, 2nd year driveline and 1st year breakdown.; ITS service.

Optional

- 08311** Service interval extended



Go to [DAF.com](https://www.daf.com) to configure your own perfect DAF.

CF 370

FAN 6X2 Rigid, Low Deck

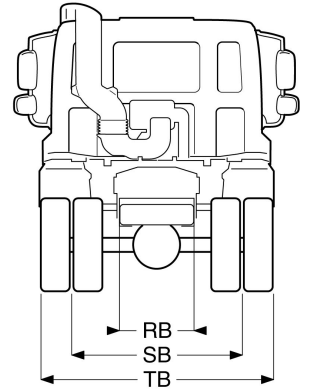
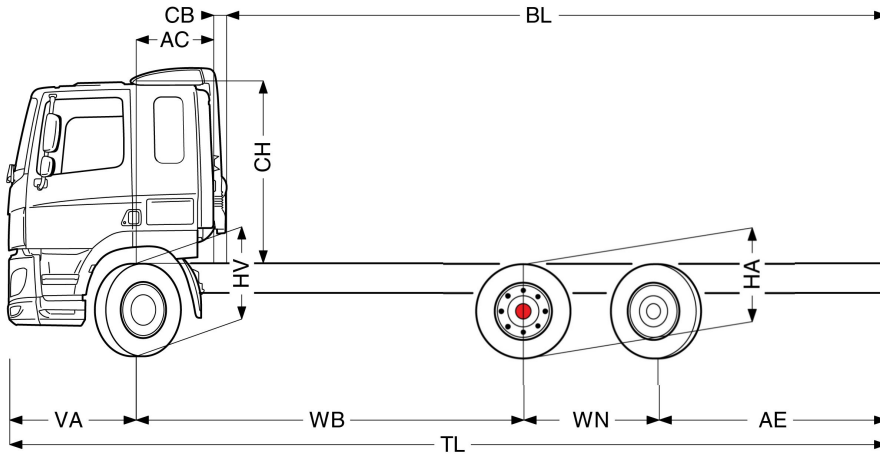

	Wheelbase - AE		Unladen weight ⁹⁾			Gross Carrying Capacity			Variable dimensions									
	WB	AE ⁹⁾	Front	Rear	Total	Front	Rear	Total	AC	CB ⁸⁾	CH ⁷⁾	BL ⁸⁾	BL	TL	HA ⁹⁾	HA ¹⁰⁾	TK ¹¹⁾	TW ¹²⁾
DAY CAB	4.60	2.75	4872	3592	8464	2628	15408	17536	0.39	0.18	1.99	7.63	7.89	10.12	0.89	0.89	15.56	16.95
	4.80	2.90	4881	3666	8547	2619	15334	17453	0.39	0.18	1.99	7.96	8.25	10.47	0.89	0.89	16.08	17.48
	5.05	3.10	4873	3712	8584	2627	15288	17416	0.39	0.18	1.99	8.38	8.68	10.92	0.89	0.89	16.73	18.14
SLEEPER CAB	4.60	2.75	4931	3597	8528	2569	15403	17472	0.82	0.16	1.99	6.83	7.11	10.12	0.89	0.89	15.56	16.95
	4.80	2.90	4941	3671	8611	2559	15329	17389	0.82	0.16	1.99	7.17	7.46	10.47	0.89	0.89	16.08	17.48
	5.05	3.10	4932	3716	8648	2568	15284	17352	0.82	0.16	1.99	7.60	7.89	10.92	0.89	0.89	16.73	18.14
SPACE CAB	4.60	2.75	5029	3598	8627	2471	15402	17373	0.82	0.16	2.67	6.89	7.16	10.12	0.89	0.89	15.56	16.95
	4.80	2.90	5039	3672	8711	2461	15328	17289	0.82	0.16	2.67	7.23	7.51	10.47	0.89	0.89	16.08	17.48
	5.05	3.10	5030	3717	8748	2470	15283	17252	0.82	0.16	2.67	7.65	7.94	10.92	0.89	0.89	16.73	18.14

OTHER DIMENSIONS	VA: 1.37	WN: 1.40	HV ¹³⁾ : 0.89	HV ¹⁴⁾ : 0.89	RB: 0.79	SB: 1.82	TB ¹⁵⁾ : 2.48
------------------	----------	----------	--------------------------	--------------------------	----------	----------	--------------------------

- GVM in conformity with registration documents.
- GCM in conformity with registration documents.
- Axle load with standard tyre size.
- Chassis and cab weight calculated with: Standard specification items only with 450 litres of fuel, 45 litres of AdBlue® and driver of 90 kg, tolerance ± 3%. Changing of the specification can have major impact on vehicle weight.
- Other AE dimensions may be available for shown WB. Modify rear overhang to the calculated body length.
- CB is based on standard air intake and/or exhaust.
- Cab height is measured from frame member to closed cab roof hatch. With air intake on cab roof add: 0.14 m (for MX-11); add 0.21 m for MX-13.

- Calculate customer specific body length with TOPEC. Body lengths shown based on evenly distributed load at max axle load.
- Unladen height at centre of driven axle (trailing axle down).
- Laden height at centre of driven axle(s).
- TK = turning circle between kerbs.
- TW = turning circle between walls.
- Unladen height at centre of front axle(s).
- Laden height at centre of front axle(s).
- TB is overall width at rear. (At lower cab step 255).

Depending on the vehicle configuration a specific option may not be possible. The availability and specification of this vehicle may differ per country. For further information please contact the DAF organisation. Pictures and technical illustrations are not binding in detail and can differ from the standard specification. Subject to modification without prior notice.