



BiG X

700/850/1100

Precision-chop forage harvester



BiG X 1100

The world's most powerful forager



- New: Open-space comfort cab
- New joystick for ultimate operator comfort
- New up to 1,078 hp MAN engines
- Spring-loaded VariStream base, optional Biogas cutterhead with 40 knives Super Biogas cutterhead with 48 knives
- EasyCollect 1053 – the world's widest header cuts 14 rows of maize in one pass





BiG X
The new dimension of strength and comfort

Cab	4
Engines	6
Crop flow	8
Cutterhead	10
Corn-Conditioner	12
Corn head	14
Pick-up	18
Direct Cut Head	20
Operator Assist Systems	22
Technical data	26



The cab

Ultimate level of comfort

- Extremely spacious and quiet
- Highest seating comfort, easiest operation
- Best all-round vision



Wider, quieter, brighter:

The wide and slim posted cab offers plenty of space and best view on wide corn headers and thanks to its double floor, it is quieter too. 16 H9 lights give perfect illumination and Xenon lights are options.

Everything under control:

High side windows and the slim posts give operators an unobstructed view on the spout even when unloading height is as high as 6 m (19'8"). So, filling the trucks is safer and more effective.



A milestone in advanced ergonomics

Long working days, sometimes extending long into the night, require a working environment that offers appropriate comfort. The new and open-plan Silent Space cab was developed to the latest ergonomic standards. Providing generous space and an extra buddy seat, it offers a fully air-conditioned and absolutely functional working place, where the operator feels at home and has full command of all controls.



User friendly and good:

The new and ergonomic joystick with user friendly decals allows operators to control this monster machine at the tip of a finger. The slim stick sits comfortably in the hand and is a special development for the BiG X 700, 850 and 1100 models. With more than 20 functions programmed to it, it not only controls ground speed and direction of travel but also header and spout.



Well laid out:

The switches for lights, windshield wiper, heating and air conditioning are located directly in front of the driver above the window. The Follow Home Function lets you get down from the cab safely. After you key off at night, two work lights follow you home for three minutes.

Everything within insight:

The KRONE EasyTouch info terminal with high definition color display, records all operating data which is retrieved by operating the dial. The operator also enters a number of settings here, including the chopping length. The well laid out control panel next to the air seat stores and controls all machine functions including ground drive and chopping cylinder drive.





The new engines

More power, less fuel

- High fuel economy
- Quiet running
- Less maintenance



Ventilating only if necessary:

For the engine to operate within the optimum temperature range, the radiator on BiG X is controlled hydraulically and relative to the current temperature. When the temperature is low, the radiator operates at lower speeds, saving fuel and reducing the noise level.

Infinitely variable drive power:

The wheel motors, the six pre-compression rollers and the headers are driven by hydraulic pumps. The system offers infinitely variable adjustment of cutting lengths and corn head speed.

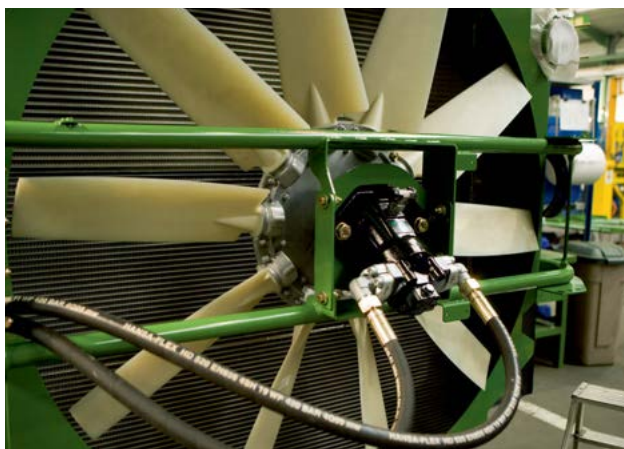

How much power do you need?

Cutting-edge engine technology from MAN takes power and economy to a new dimension. Common Rail injection and the single engine concept lead to quiet running, low fuel consumption, high efficiency and lowest maintenance. The innovative KRONE Power Management system allows operators to switch from Eco Power mode to X Power mode and vice versa and adjust engine output to current requirements.



V 8, 16.16 l engine

BiG X 700

Engine output to ECE R120:	570 kW / 775 hp
Constant X Power during chopping:	492 kW / 669 hp
Constant Eco Power during chopping:	374 kW / 509 hp

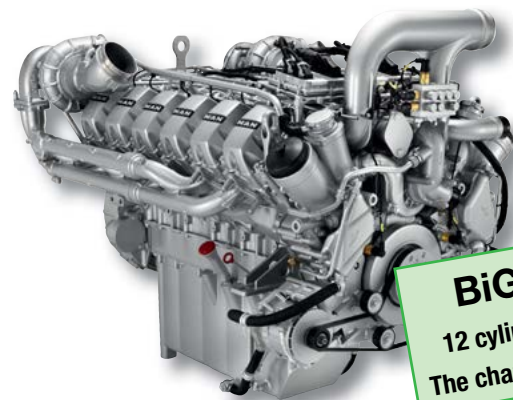

BiG X 1100
12 cylinders – 1,078 hp
The champion in its league

V 12, 24.24 l engine

BiG X 850

Engine output to ECE R120:	625 kW / 850 hp
Constant X Power during chopping:	607 kW / 825 hp
Constant Eco Power during chopping:	469 kW / 638 hp

BiG X 1100

Engine output to ECE R120:	793 kW / 1,078 hp
Constant X Power during chopping:	760 kW / 1,034 hp
Constant Eco Power during chopping:	469 kW / 638 hp

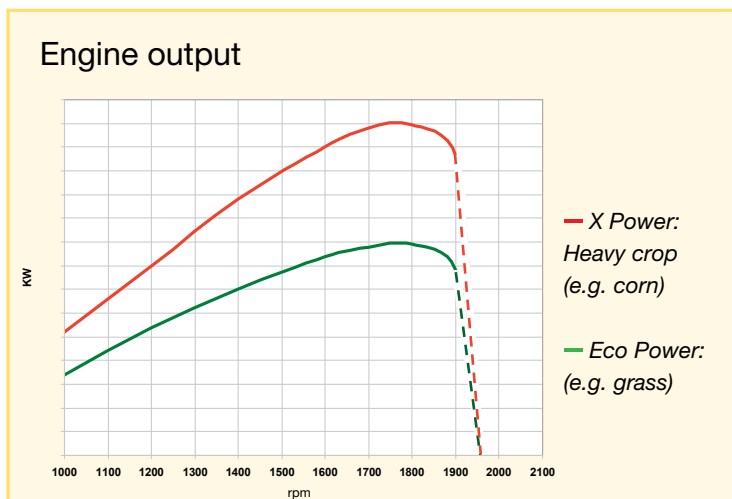

Eco Power – X Power

Eco Power is used in situations where it is not necessary to operate the forager at full power. When the situation changes and the engine power requirement increases, simply select X Power by flicking a button or – as an option – automatically relative to the current load on the engine. The system gives you the flexibility to respond to the job at hand and helps you reduce fuel consumption and save the environment.

VariStream

A continuous flow



- Best quality of chop thanks to 6 pre-compression rollers
- More throughput, less fuel consumption: Optimized crop flow
- Uniform performance even in varying crop masses



Safe and convenient:

Six pre-compression rollers and a 820 mm (2'8") clearance between the leading roller with metal detector and the opposite knife not only enhance the pre-compression effect but also the degree of protection from metal objects. The hydraulic drive system allows operators to vary the length of chop manually or automatically relative to the maturity of the crop via the patented KRONE AutoScan system.

Large throat volume:

This massive throat opening ensures BiG X puts through largest masses. With over 4.6 tons of compression force on the six rollers the quality of chop is better and fuel consumption per ton of crop is lower.

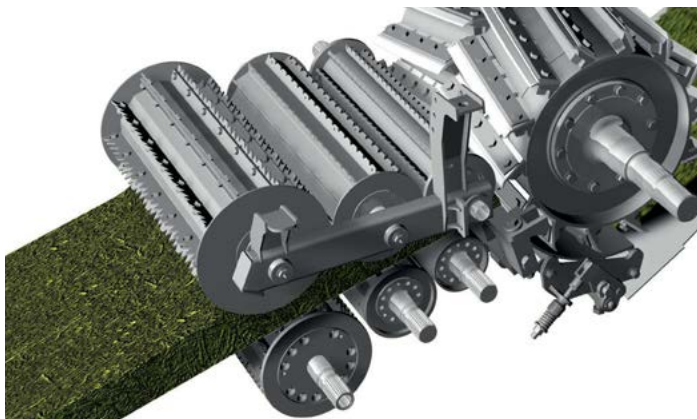

VariStream

Utilization is up, consumption is down

Highest throughputs and a superior quality of chop require a technology to match. This in turn requires many innovative details such as the six hydraulic-drive pre-compression rollers, the large cutterhead with up to 48 knives and the award winning VariStream crop flow. Consisting of a spring-loaded floor beneath the chopping cylinder and a spring-loaded back plate in the crop accelerator housing, VariStream ensures blockage-free and smooth operation, even when the flow of crop is not uniform. Forager utilization is maximized to its limit and fuel consumption drops per ton of crop harvested.

**VariStream
INSIDE**

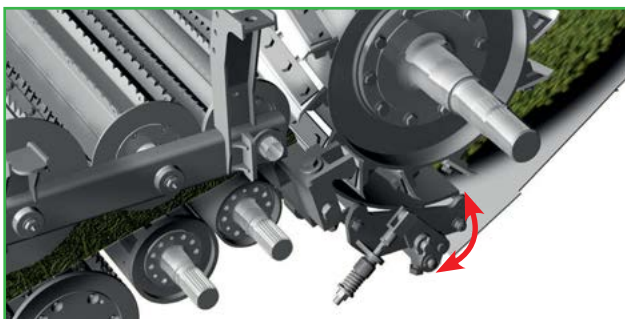
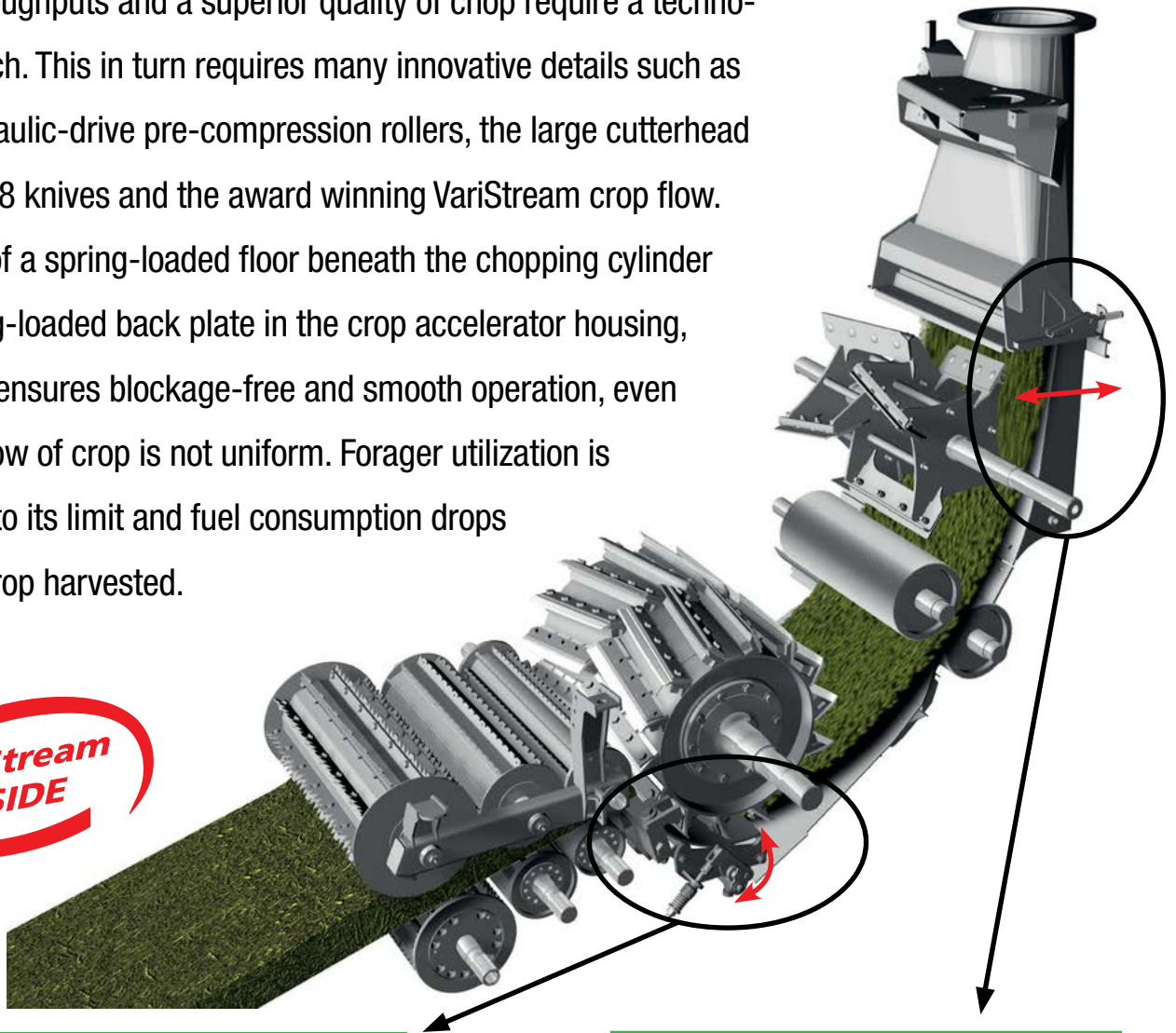

Best quality of chop even though the flow of crop is not uniform:

The floor beneath the chopping cylinder is linked to the anvil of the opposite knife. This way, the clearance between any one knife on the cutterhead and the opposite knife is always constant. Although the floor beneath the chopping cylinder moves away from the cylinder as crop masses increase, it does not affect the quality of chop.

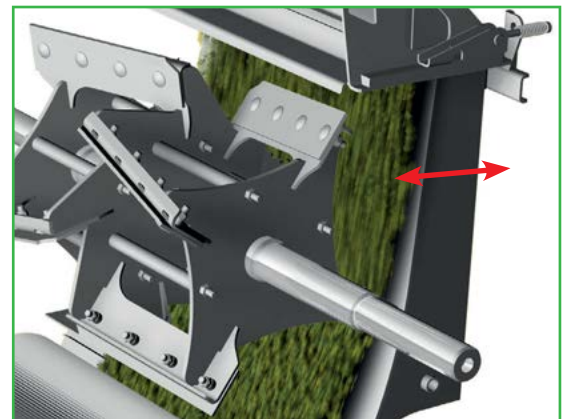

A consistent throw and a tight stream:

The spring-loaded back plate of the crop accelerator housing ensures the best unloading efficiency in all conditions, filling the trailer to precision.



The core

The KRONE Biogas Cutterhead

- 660 mm (2'2") Ø and 800 mm (2'7.5") cutting width
- Low fuel consumption thanks to a high momentum and crop being pulled passed the knives
- The 40-knife Biogas cutterhead delivers an ultimate cutting frequency and an amazing efficiency



"Standard cylinder versus Biogas cylinder"

Chop length: 5 mm (0.2")

Consumption (l/t fresh mass)

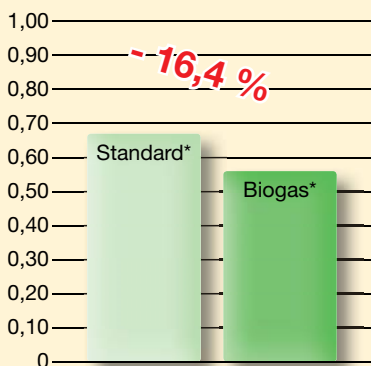

Throughput (t of fresh mass/h)

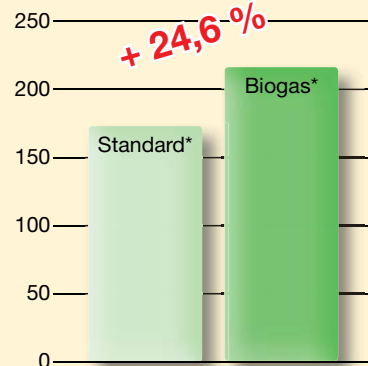

*Standard = 28 knives

*Biogas = 40 knives

More output, lower costs:

Chopping the crop to short lengths, the use of the KRONE Biogas cylinder with 40 knives increases the throughput by nearly 25 % over what is achieved by a standard 28-knife cylinder. At the same time, fuel consumption drops by up to ca. 16 % per chopped crop.*

* results from the 2006 Krone workshop that was covered by international agricultural magazines

All-purpose

Choose between the cutterhead for long-stemmed crop, the standard cutterhead, the Biogas or the Super Biogas cutterhead. The 660 mm (2'2") diameter and 800 mm (2'7.5") wide cylinders with knives arranged in a chevron pattern deliver top-quality chops and a consistent crop flow while being frugal on tractor power. 40 or 48 knives ensure a high chopping frequency so the machine can travel faster, even when the BioGas cylinder is cutting short chops.



48-knife cylinder

The new Super Biogas cutterhead with 48 knives is our response to the needs of modern biogas plants. Cutting at a more than 20% higher frequency and producing chops with a nominal length of 2-12 mm (0.1"-0.5"), the 48-knife drum chops even shorter. This leads to higher gas yields and throughputs at the biogas plant. Moreover, consumption per tonne of harvested crops drops dramatically.



40-knife cylinder

Boosting throughputs and reducing consumption, this Biogas cylinder with its 40 knives soon pays for itself. Also, it keeps the number of coarse chops to an absolute minimum, which ultimately boosts the efficiency of the fermenter at the biogas plant. As gas yields at the plant increase, fuel consumption drops significantly per acre harvested and cubic volume of biogas produced.



28-knife cylinder:

This cylinder is standard specification on all BiG X models. Use half this number of knives and this universal cylinder cuts grass to proper lengths.



20-knife cylinder:

This is the cylinder to cut long lengths, which are desired in some countries.

Corn Conditioner

Two systems for your success

- Massive 250 mm (10") diameter rolls for perfect conditioning
- New – optional heavy-duty disc conditioner on BiG X 1100 gives a 2.5-times larger friction surface
- Fast and easy fitting and removal
- Roll gap adjusts conveniently from the cab!

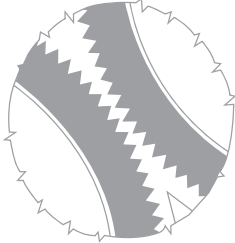
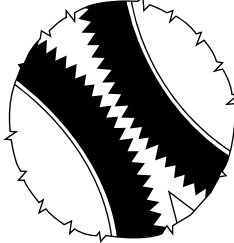
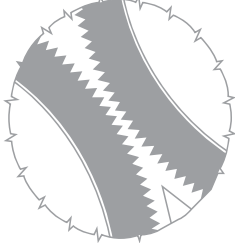

Roller Conditioner			
No. of teeth	123	144	166
Form of teeth	Triangle	Triangle	Saw tooth
Application	Long stalks	- Universal chop length - Ideal for European silage maize - suits total plant silage	- Whole crop silage Conditioner that cracks small kernels most effectively - Cracks whole crop silage more effectively between soft dough stage and full ripeness.
Works in combination with:	Long-stalk drum	- Long-stalk drum - Standard drum (28) - BioGas drum (40) - Super BioGas drum (48)	- Standard drum (28) - BioGas drum (40) - Super BioGas drum (48)

Optimal digestibility

Livestock farmers ask for forage that is very easy to digest. This means every single kernel needs to be cracked, even when the chopping lengths are long. The KRONE Corn Conditioners deliver just that. Larger diameters and larger friction faces account for top quality conditioning, higher throughputs and reduced power inputs.

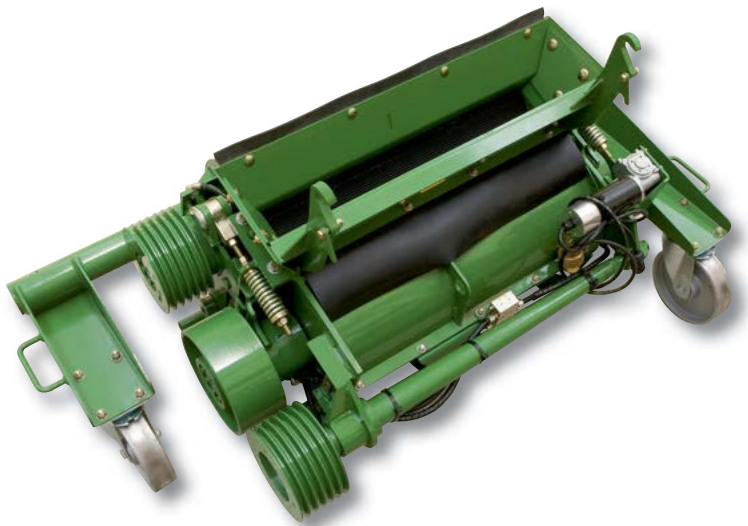

KRONE Corn Conditioner cracks every kernel

The 250 mm diameter rollers have a larger friction surface area than the smaller-diameter toothed rollers, can be operated at a larger roll gap and give you more harvest power at higher economy along with better conditioning results in long stalks. The speed difference between the two shafts is 20% or an optional 30/40% when harvesting whole crop silage. The new KRONE disc conditioner offers a larger friction surface than existing units to implement those high throughputs on BiG X 1100. Fitting/removing the Corn Conditioner takes only a few minutes.



The standard toothed roller

The rollers on the standard Corn Conditioner are equipped with 123, 144 or 166 teeth. The huge 250 mm (10") diameter pays off quickly and allows you to step up your workrates and quality levels.



Chromed toothed rollers

Made up of 250 mm (10") diameter rollers with up to 123 or 144 teeth, the chromed Corn Conditioner is tremendously durable and gives you an extremely long service life.



Disc shaft assembly

The disc conditioner assembly is made up of two shafts with interlocking discs to give V-shaped gaps to crack the kernels. This design makes for a 2.5-times bigger friction face over a standard conditioner. As a result, throughputs are higher and the kernels receive the best possible treatment. The two shafts in the assembly spin at identical speeds and so reducing the required input by up to 10%.

EasyCollect

Boosting profitability

- Up to 10.50 m (34'5") working width – a KRONE exclusive
- Best quality of chop, lower rate of over-length fractions as stalks are fed in longitudinally
- Straightforward design – less wear and input power

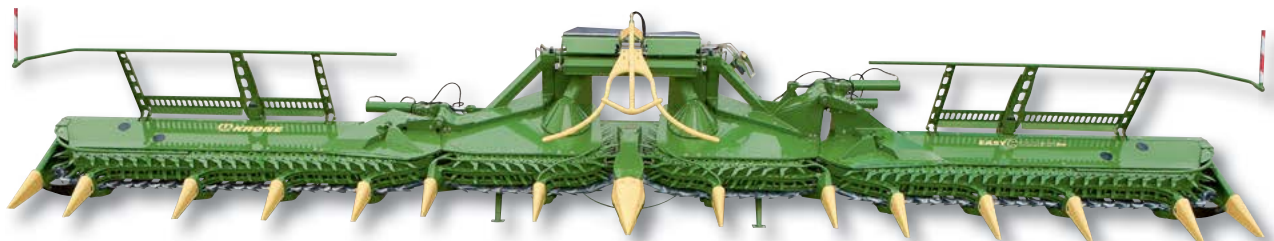

Unique width – strong output:

The row-independent header with the world's widest working width of 10.50 m (34'5") is available as an option for BiG X. The endless collector feeds the stalks to the

middle of the machine, where they perform a 90° turn to be pulled in longitudinally. This is the ideal system to achieve best quality of chop at fewer overlengths.

EasyCollect – Quality of chop starts at the header

The row-independent EasyCollect header is a versatile unit that impresses by feeding the stalks longitudinally into the machine, which leads to an unsurpassed quality of chop, because coarse chops are not desired in livestock farming and biogas production. The unique collector principle stands for low system costs and has proven fantastically well the world over.



**Compact transport position:
The triple-fold EasyCollect header**



Pulling the crop over the cutting edges:
Rigid multi-section knives and endlessly moving knives cut the stalks like scissors. The knives are self-sharpening and easy to replace.

Model	Work width	Fold-up	Comments
6000 FP	6.00 m (19'8")	Double	Suits JD, CNH, Claas
6000	6.00 m (19'8")	Double	–
603	6.00 m (19'8")	Triple	–
753	7.50 m (24'7")	Triple	–
903	9.00 m (29'6")	Triple	–
1053	10.50 m (34'5")	Triple	–

'Small corn head versus big corn head'

Chop length: 12 mm (0.5")

Consumption (l/t fresh mass)

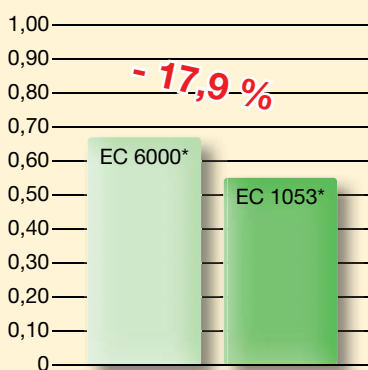

EC 6000* = 6.00 m (19'8") work width

Throughput (t of fresh mass/h)

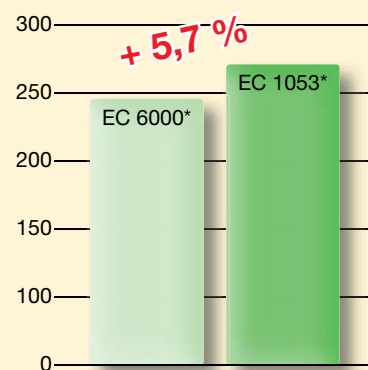

EC 1053* = 10.50 m (34'5") work width

Wider is better:

Using the 10.50 m (34'5") EasyCollect 1053 corn head increases throughput approx. 5.7 % over using the 6 m (19'8") EasyCollect 6000 header. At the same time fuel consumption drops by up to 18 % per ton of chopped corn. Not only are wider headers more economically but have a quieting effect on the harvest chain.*

*results from the 2006 Krone workshop that was covered by international agricultural magazines



Ingeniously simple – simply ingenious

EasyCollect stands out for its modular and straight-forward design with endlessly moving collectors. The design leads to a substantial reduction in weight, less maintenance and enhanced longevity.



Positive crop guidance

EasyCollect performs dependably in any situation and condition, neatly collecting each row of crop, feeding the stalks to the middle and on to the cutterhead. It is this smooth feed in a longitudinal direction that leads to best results on the cutterhead.



A uniform stubble height

Distance sensor arms on either end of the EasyCollect corn head adjust the depth both transversely and in direction of travel, leading to a uniform stubble height also in undulating terrain.



Optimizing the crop flow

The crop divider adjusts hydraulically to various stalk lengths to grab the stalks at the top and pull them into the machine. The divider folds up into transport position.



Secure guidance

When using Autopilot, the sensor arms on the central cone scan the distance between two corn rows. Then BiG X is guided automatically along that row, which helps reduce operator fatigue.



Widest intake system

The EasyCollect intake channel dimensions match the width of the cutterhead and ensure maximum throughput with maximum quality of chop. The inline flow of the crop and the large intake combine to provide a steady and very tidy crop feed.

EasyFlow

Pick-up without cam track

- More output, quiet running, less wear
- Highest comfort as pick-up speed is matched to ground speed
- Infinitely variable speeds



Two work widths:

Working at widths of 3.00 m (9'10") or 3.80 m (12'6") and using six rows of tines that are spaced 55 mm (2.2") apart, these KRONE pick-ups take up everything – even when picking up high-volume swaths at high ground speed. The pendulum frame on the intake system

gives the unit flexibility to adjust transversely to ground undulations. The robust design has proven exceptionally well in the most difficult conditions and is another detail in optimizing utilization of this powerful machine. Shafts protected by friction clutches.



EasyFlow – another KRONE exclusive

EasyFlow 3001 and 3801: The KRONE EasyFlow pick-up operates without guide rollers and cam tracks. This leads to 58 % reduction in moving parts over traditional pick-ups and hence much quieter running. Fewer parts mean less wear and this in turn means reduced service and maintenance costs. EasyFlow operates at a 30 % higher speed for cleaner gathering and higher productivity.

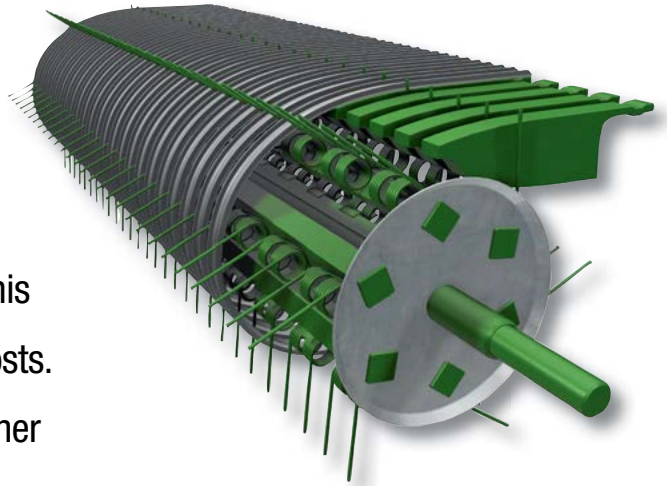

Camless is better:

The unit stands out for its galvanized scrapers of a special design that ensures a continuous flow of crop as the tines retract.

Perfect

Operators adjust the EasyFlow pick-up from the cab to match its speed to current swath volumes and ground speeds. If equipped with the automatic adjustment system, the machine will vary pick-up speed to conditions without interference from the operator. One or two gauge wheels at the rear and the pendulum frame on the intake system provide extra ground contour following.

Comfort that takes the hard side out of work:

Reversing automatically raises the cross auger and the large roller crop guard for easy removal of foreign objects detected by the metal detector. As the forager

resumes travel, the crop guard and auger return automatically to their previous working position. The gauge wheels swing hydraulically into transport position.



XDisc

The direct cut head

- High throughput, low input
- KRONE EasyCut disc mower technology – proven the world over
- KRONE SafeCut for maximum safety



Cutting and chopping in one pass:

KRONE XDisc is the versatile specialist mowing unit for whole crop silage. XDisc cuts the crop cleanly and free of loss. The huge 900 mm (2'11") diameter auger adds

more capacity to BiG X and picks up long and bulky crop without any problem.



XDisc: Your cutting edge

Whole crop silage is gaining more and more importance in agriculture, both as animal feed and raw material in the bio-energy industry. The 6.20 m (20'4") wide XDisc cuts and chops the crop in one operation. XDisc 6200 is powerful and harvests without losses and with outstanding cutting quality.



1. Safe road travel at 40 km/h (25 mph):

Placing the XDisc unit on the transport trailer is easy and quick – a special development. The integral brake system gives you true peace of mind.

2. SafeCut inside – a KRONE exclusive:

The unique protection system protects discs and their drives from damage by foreign objects. A roll pin in the sprocket driveshaft breaks when there is a momentary overload. This cuts the driveline and stops the disc, which jacks up a thread, eliminating any risk of colliding with the neighbouring disc.

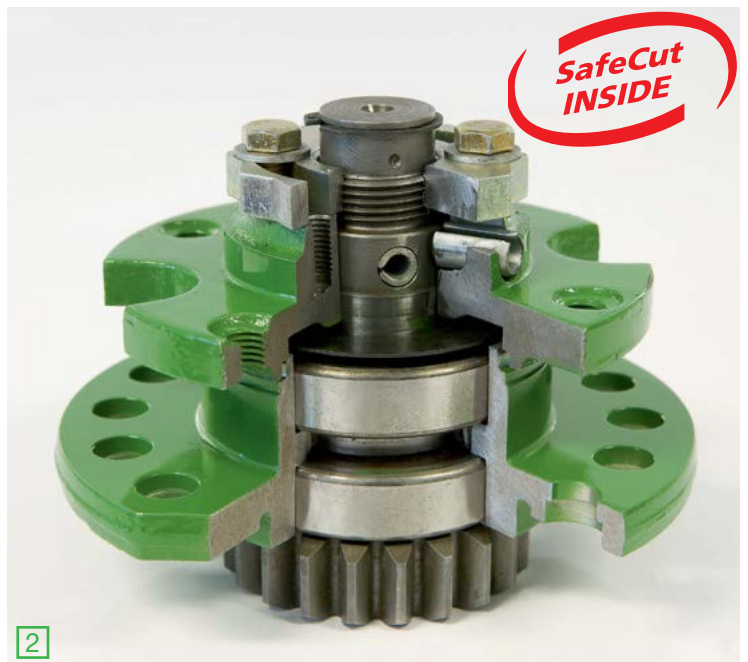

3. Clean cuts, safe and convenient:

The welded cutterbar boasts massive spur gears for heavy-duty operation and quiet running. Blades are quick-change to save time and money. With blades overlapping generously, XDisc leaves a clean cut.

4. Massive throughput:

The powerful auger boasts a 900 mm (2'11") diameter and delivers trouble-free operation in massive and high crops. The pivoting unit has a reversing mechanism and the auger flights have replaceable Hardox steel wear liners.

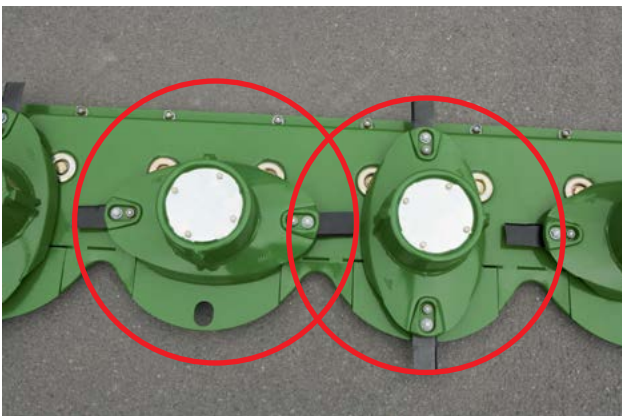

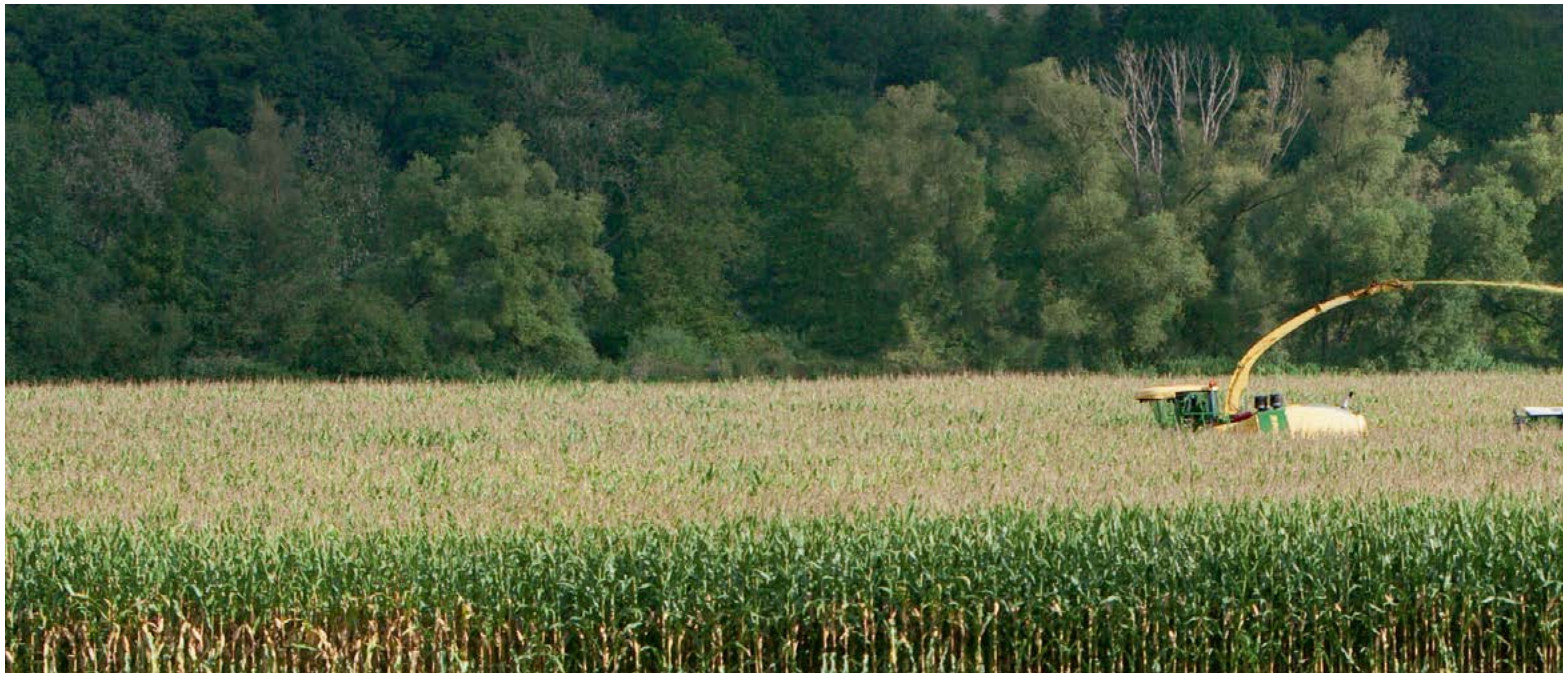

Simply more BiG X

Ican is KRONE's electronic system that optimizes machine utilization even further and provides a substantial relief to the operator. Ican gives peace of mind in arduous conditions plus it reads out all relevant harvest information.



AutoScan:

Adjusting chop length automatically to crop maturity

The photo-optic sensor in the middle of the corn head measures the maturity of the plant and automatically adjusts the length of cut to achieve a uniform chop quality and reduce silage effluent in the clamp by leading to longer cuts in green corn. Vice versa, when harvesting dry corn the material is cut to shorter chops for more effective compaction in the clamp. AutoScan reduces driver effort and saves fuel, because the stalks are cut only as short as necessary and not as short as possible. AutoScan is a KRONE standard and not an expensive extra.

ConstantPower:

Automatic engine top speed control

ConstantPower automatically adjusts the machine's ground speed to the engine loading. Select the desired engine loading at a touch of a button. The machine adjusts fully automatically forward speed to match the current crop conditions and yield levels. This standard feature reduces operator stress and ensures highest throughputs at lowest fuel rates. In combination with AutoScan the system adds another dimension to the overall quality of chop and machine performance





**RockProtect:
Stone detector**

The 6 pre-compression rollers are powerful and soft at the same time. They halt fully automatically within milliseconds after the RockProtect system detects a stone. The optional system provides intelligent protection from damage by stones, with the operator setting its sensitivity. More protection – more peace of mind.



**CropControl:
Yield metering**

The optional yield metering system from KRONE measures the volume of crop currently harvested. Retrieve the data from a touch of a button and print it out at the end of the day – both individual field counts and total count. CropControl allows you to document all yield information on the fields harvested by you.



**ForageCam
Remote camera view on loading area**

As an optional extra, a CCTV camera on the spout remotely transmits footage to the forager's in-cab terminal and to the terminal on the haulage tractor. The CCTV camera helps the operator utilize the full load space of haulage trucks and reduces fatigue at the same time. The system can be expanded to communicate with multiple receivers on all haulage tractors in a large haulage chain.



ISOBUS autoguidance

The guide to maximum work widths



As an optional extra, BiG X is prepared to accept ISOBUS guidance systems from various manufacturers. This level of specification enables operators to use an existing autoguidance system according to the 'plug & play' principle. It takes just a few minutes to integrate such an advanced ISOBUS guidance system on BiG X.



On the move, the operator activates autoguidance using the KRONE joystick simply by pressing a button and then watches how the system guides BiG X down the track. Autoguidance reduces operator fatigue, boosts workrates also in broadcast seed and hence increases your efficiency.



NIR crop moisture sensing system

Getting accurate data



The NIR sensor provides exact data on the level of crop moisture. This information is then allocated to the area within the customer memory. The sensor sits in a solid casing where it is protected.



The moisture level is measured on BiG X's spout, where a consistent flow of crop is the prerequisite for perfect data collection results. The sensor is easy to attach and is protected by a cover.

Technical data

BiG X

		BiG X 700	BiG X 850	BiG X 1100
Engine Model		MAN V8 D 2868	MAN V12 D 2862	MAN V12 D 2862
No. of cylinders		8	12	12
Displacement	Litres	16.16	24.24	24.24
Power (to ECE R 120 standard)	kW/hp	570/775	625/850	793/1,078
Max. chopping power in X Power mode	kW/hp	492/669	607/825	758/1,031
Max. chopping power in Eco Power mode	kW/hp	374/509	469/638	469/638
Fuel tank capacity / auxiliary tank		960/330		
Ground drive				
Type		Infinitely variable hydrostatic drive with wheel motors		
Speed in field mode	km/h	0-22 (0-14 mph)		
Speed in road mode	km/h	0-40 (0-25 mph)		
4WD & axle separation		Standard		
Axles				
Steering angle on rear axle	Degrees	53		
Rear axle suspension		Standard - Hydraulic		
Drivelines				
Header		Infinite variable		
Pre-compression rollers		Infinite variable		
Pre-compression rollers				
Pre-compression roller throat volume		Funnel shaped		
Service position		Quick attach (also with head attached)		
No. of rollers/metal detector/no. of magnet coils		6/Standard/6		
Metal detector to shearbar distance	mm	820 (2'8")		
Compression force / Throat opening volume	kg/l	4,600/158 (10,141 lbs/158)		
Chop length adjustment		Steplessly from cab (0.2 mm (0.008") increments)		
Cutterhead				
Cutterhead width / diameter	mm	800/660		
Arrangement of knives		Chevron arranged at 11° to shearbar		
No. of knives		20, 28, 40, 48		
Chop length range		5-29/4-21/2.5-15/2-12		
Cuts / min.		11,870/16,620/ 23,740/28,490	12,500/17,500/ 25,000/30,000	12,500/17,500/ 25,000/30,000
Stepless adjustment of drum flow / spring-loaded drum floor		Standard/Standard		
Corn-Conditioner				
123 teeth: Straight teeth / chromed saw teeth		Option/Option		
144 teeth: Straight teeth / chromed saw teeth		Option/Option		
166 teeth: Saw teeth		Option		
Roller speed difference	%	20		
In-cab roller gap adjustment & automatic lubrication		Standard		
Roller diameter / clearance	mm	250 (9.8")/0.5-10 (0.02" - 0.4")		
Disc rolls		-	-	Option

All specifications, weights and dimensions do not necessarily comply with standard specifications and are therefore not binding.

		BiG X 700	BiG X 850	BiG X 1100
Crop accelerator				
Rotor diameter / Width / No. of paddles		560/660/8		
Paddle arrangement		Centered and chevron		
Speed	rpm	2,360		
Stepless adjustment of the back plate / spring-loaded back plate		Standard/Standard		
Spout				
Rotation	Degrees	210		
Overhead unloading height	mm	6,000 (19'8")		
Cross section	mm	340x230 (1'1" x9")		
Automatic rotation / parking function		Standard		
Stepless speed adjustment		Standard		
Drive for rotation		Gearbox		
Spout fully covered with wear liners		Standard		
Maintenance				
Auto-lube system with compressor		Standard		
Self diagnostic system via operator terminal		Standard		
Cab				
Air seat & passenger seat		Standard		
Auto climate with mobile cool box		Standard		
Windscreen wiper / side window wiper		Standard		
Dimensions				
Length / Width* / Height*	mm	7,950-9,450/3,000-3,460/3,940-3,995 (26'1" - 31'9"/10" - 11'4" / 12'11" - 13'1")		
Base unit weight (without header)**	ca. kg	14,350 (31,636 lbs)	14,800 (32,628 lbs)	14,800 (32,628 lbs)
Weight distribution with EasyFlow 300 Pick-up	F/R %	55 - 45		
Weight distribution/with EasyCollect 903 (9.00 m w.w.)	F/R %	60 - 40		
Tires ***				
Front axle	Standard****	650/75 R32		
	Option	710/75 R34		
	Option	710/70 R42		
	Option	800/65 R32		
	Option	900/60 R32		
	Option	800/70 R38		
	Option	900/60 R38		
Rear axle	Standard****	540/60 R30		
	Option	600/70 R28		
	Option	710/60 R30		
Headers				
EasyFlow: Pick-up	mm	3,000-3,800 (9'10" - 12'6")		
EasyCollect: Row-independent header	mm	6,000/7,500/9,000 (19'8" / 24'7" / 29'6")	7,500/9,000/10,500 (24'7" / 29'6" / 34'5")	7,500/9,000/10,500 (24'7" / 29'6" / 34'5")
Autopilot & Active ground contouring for Corn Head		Option		
XDisc: Direct Cut Head	mm	6,200 (20'4")		

* Dependent on tire configuration

** Dependent on level of specification

*** does not combine with any tyre

**** Use depends on header used

KRONE Website



Discover the world at KRONE and visit us www.krone.de. Browse through our pages and find facts and figures as well as new development and a wide range of service options. Surf our website and find out how versatile the KRONE world is.



News

Click here to find up-to-the minute information on KRONE – from new product presentations to show reports. Here you have your finger on our pulse.



Products

Find extensive information on our full product range. This section holds anything you may look for – from video clips to manuals.



Sales organisation

Here you find a distributor in Japan as well as your local KRONE dealer who will be please to support you.



Jobs

Would you like to work for KRONE? KRONE is often looking for diligent and motivated staff members at both our farm machinery factory and our commercial trailer production plant. This section is always worth a visit.



Media center

The KRONE 'data base' holds thousands of documents, pictures, test reports and much more. Here you will also find very detailed information on the KRONE products that are of special interest to you.



Events

Are you in for a KRONE live experience? Check out for upcoming events where you can see KRONE machinery either on show or in demonstration. After all, little is more effective than a hands-on experience.



Service

Here you find all the service information you require – from a point of contact at the factory to financing your KRONE machine. Also, you find a plan on our training modules both for engineers and users.



Download Center

Are you looking for a KRONE calendar for your desktop or a smart picture for your presentation? Here, at the KRONE download area, you will find plenty of useful items for a wide range of projects.



Used Machinery

KRONE often has a wide range of demonstration or exhibit machinery on offer. This is a good site to find your KRONE machine. Then contact your local KRONE dealer to arrange the details of a potential purchase.



Parts

This 24/7 service gives you the opportunity to find your KRONE part any time and without waiting. The KRONE Agroparts Portal offers all parts with an article number and exact description. You can order the part instantly at your local KRONE dealer by sending an e-mail to Agroparts.



KRONE shop

Are you looking for a gift or are you a collector of farm models? Then you should definitely shop at our KRONE shop. We take your orders at any time of the day.

Your KRONE dealer

Maschinenfabrik Bernard KRONE GmbH

Heinrich-Krone-Straße 10
D-48480 Spelle

Telefon: +49 (0) 5977.935-0
Telefax: +49 (0) 5977.935-339

info.ldm@krone.de
www.krone.de