

# Hiab XS 066

## Range 5-7 tm



# Hiab XS 066 Basic data

## Technical data

	B-2 CL	D-2 Duo	D-3 HiDuo	D-4 HiDuo
Max. lifting capacity (kNm)	53	59	61	58
Outreach - hydraulic extensions (m)	7.3	7.3	9.3	11.3
Outreach - manual extensions (m)	9.1	11.3	11.3	-
Outreach / Lifting capacity, standard (m / kg)	2.7 / 2040	2.5 / 2360	2.9 / 2140	3.1 / 1940
	3.8 / 1420	3.9 / 1540	4.0 / 1560	3.9 / 1520
	5.4 / 980	5.4 / 1080	5.5 / 1080	5.5 / 1020
	7.2 / 720	7.2 / 800	7.3 / 800	7.3 / 720
	-	-	9.3 / 620	9.2 / 540
	-	-	-	11.1 / 450
Slewing angle	410°	410°	410°	410°
Height in folded position (mm)	1900	1900	1900	1900
Width in folded position (mm)	2160	2015	2150	2170
Installation space needed (mm)	565	650	650	650
Weight - "standard" crane without stabilizers (kg)	850	870	950	1020
Weight - stabilizer equipment (kg)	105 - 160	105 - 160	105 - 160	105 - 160

## Hiab XS 066 D-4 HiDuo

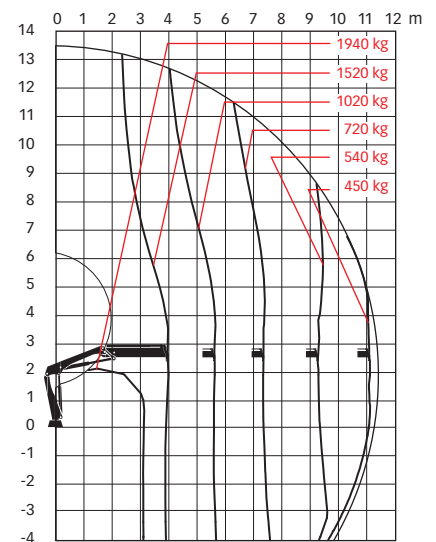
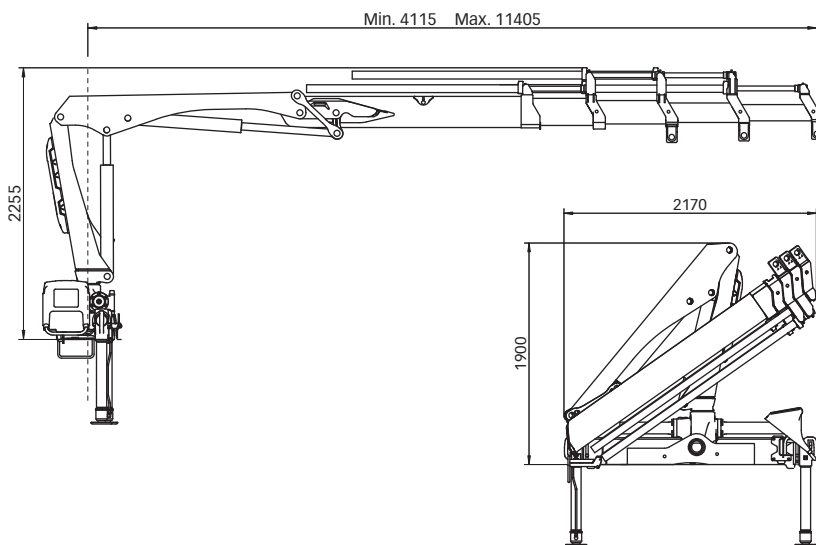

**Disclaimer.** Hiab cranes have been built to meet the highest standards of safety and service life and have been thoroughly tested. Strength calculations for this model have been carried out in accordance with EN13001 in fatigue class S1. Cargotec's certified Quality Assurance System complies with ISO 9001. Some of the items in our literature may be extra equipment. Certain applications may require an official permit. We reserve the right to change technical specifications without prior notice. Hiab cranes produced for EU-countries are CE-marked and comply with the European Standard EN 12999.

**Cargotec** improves the efficiency of cargo flows by offering solutions for the loading and unloading of goods on land and at sea – wherever cargo is on the move. Cargotec's main daughter brands for cargo handling Hiab, Kalmar and MacGregor are global market leaders in their fields. [www.cargotec.com](http://www.cargotec.com)