



RX 60-16

RX 60-18

RX 60-20

RX 60 Technical Data.

Electric forklift trucks.



This specification sheet to VDI Guideline 2198 only gives the technical figures for the standard truck.
Different tyres, other masts, additional equipment etc. could give different figures.

				STILL	STILL	STILL	
Characteristics	1.1	Manufacturer					
	1.2	Manufacturer's model designation		RX 60-16	RX 60-18	RX 60-20	
	1.3	Power supply - electric, diesel, petrol, gas, mains electric		Electric	Electric	Electric	
	1.4	Type of control - hand, pedestrian, stand-on, rider seated		Rider seated	Rider seated	Rider seated	
	1.5	Carrying capacity/load	Q	kg	1600	1800	2000
	1.6	Load centre	c	mm	500	500	500
	1.8	Load distance	x	mm	355	355	365
	1.9	Wheelbase	y	mm	1448	1448	1448
	Weights	2.1	Weight		kg	3479	3479
2.2		Axle loadings laden front		kg	4175	4495	4873
2.2.1		Axle loadings laden rear		kg	904	784	644
2.3		Axle loadings unladen front		kg	1615	1615	1659
2.3.1		Axle loadings unladen rear		kg	1864	1864	1858
Wheels Chassis	3.1	Tyres - rubber (V), SE, pneu.(L), poly.(PE)		SE	SE	SE	
	3.2	Tyre size - front		18 x 7-8	200/50-10	200/50-10	
	3.3	Tyre size - rear		16 x 6-8	16 x 6-8	16 x 6-8	
	3.5	Wheels - number front (x = drive wheel)		2x	2x	2x	
	3.5.1	Wheels - number rear (x = drive wheel)		2	2	2	
	3.6	Track width - front	b ₁₀	mm	932	942	942
	3.7	Track width - rear	b ₁₁	mm	865	865	865
Basic dimensions	4.1	Tilt angle, mast/fork carriage forwards		°	3	3	3
	4.1.1	Tilt angle, mast/fork carriage backwards		°	8	8	8
	4.2	Closed height	h ₁	mm	2160	2160	2160
	4.3	Free lift	h ₂	mm	150	150	150
	4.4	Lift height	h ₃	mm	3230	3230	3150
	4.5	Height, mast raised	h ₄	mm	3873	3873	3725
	4.7	Height to top of overhead guard (cabin)	h ₆	mm	2240	2240	2240
	4.8	Seat height	h ₇	mm	1173	1173	1173
	4.12	Coupling height	h ₁₀	mm	460/350	460/350	460/350
	4.19	Overall length	l ₁	mm	2908	2908	2918
	4.20	Length to front face of forks	l ₂	mm	2061	1983	2092
	4.21	Overall width	b ₁	mm	1099	1138	1138
	4.22	Fork thickness	s	mm	40	40	40
	4.22.1	Fork width	e	mm	80	80	80
	4.22.2	Fork length	l	mm	800	800	800
	4.23	Fork carriage to DIN 15173 - class/form A or B			ISO II/A	ISO II/A	ISO II/A
	4.24	Fork carriage width	b ₃	mm	980	980	980
	4.31	Ground clearance beneath mast, laden	m ₁	mm	90	90	90
	4.32	Ground clearance at centre of wheelbase	m ₂	mm	123	123	123
	4.33	Aisle width for pallets 1000 x 1200 wide	A _{st}	mm	3439	3439	3449
4.34	Aisle width for pallets 800 x 1200 long	A _{st}	mm	3638	3638	3648	
4.35	Outer turning radius	W _a	mm	1883	1883	1883	
4.36	Inner turning radius	b ₁₃	mm	538.5	538.5	538.5	
Performance data	5.1	Speed laden		km/h	20	20	20
	5.1.1	Speed unladen		km/h	20	20	20
	5.2	Lift speed laden		m/s	0.53	0.52	0.45
	5.2.1	Lift speed unladen		m/s	0.62	0.62	0.58
	5.3	Lowering speed laden		m/s	0.51	0.52	0.53
	5.3.1	Lowering speed unladen		m/s	0.47	0.48	0.49
	5.5	Rated drawbar pull laden		N	2775	2611	2602
	5.5.1	Rated drawbar pull unladen		N	2916	2916	2905
	5.6	Max. drawbar pull laden		N	9967	9983	9663
	5.6.1	Max. drawbar pull unladen		N	9789	9789	9785
	5.7	Gradeability laden		%	11.6	10.7	10.2
	5.7.1	Gradeability unladen		%	17.0	17.0	16.8
	5.8	Max. gradeability laden		%	20.2	19.4	18.0
	5.8.1	Max. gradeability unladen		%	26.0	26.0	26.3
5.9	Acceleration time laden		s	4.1	4.3	4.3	
5.9.1	Acceleration time unladen		s	4.0	4.1	4.2	
5.10	Brakes			electr. /mech.	electr. /mech.	electr. /mech.	
E-Motor	6.1	Drive motor hourly capacity		kW	2x5.5	2x5.5	2x5.5
	6.2	Hoist motor capacity at 15% duty factor		kW	11	11	11
	6.3	Battery equipment to DIN 43531 / 35 / 36 A, B, C, no			DIN 43536 A	DIN 43536 A	DIN 43536 A
	6.4	Battery voltage	U	V	80	80	80
	6.4.1	Battery capacity	K ₅	Ah	420LA	420LA	420LA
	6.5	Battery weight		kg	1238	1238	1238
	6.6	Energy consumption 60 VDI work cycles/hour		kWh/h	4.4	4.5	4.7
Miscellaneous	8.1	Drive control					
	8.2	Operating pressure for attachments		bar	250	250	250
	8.3	Oil flow for attachments		l/min	30	30	30
	8.4	Average noise peak at operator's ears		dB(A)	<70	<70	<70
	8.5	Trailer coupling, type/DIN			Bolt	Bolt	Bolt

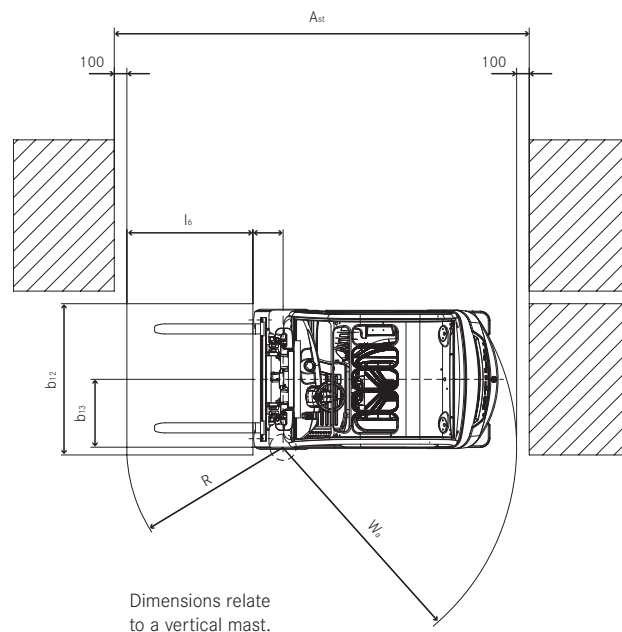
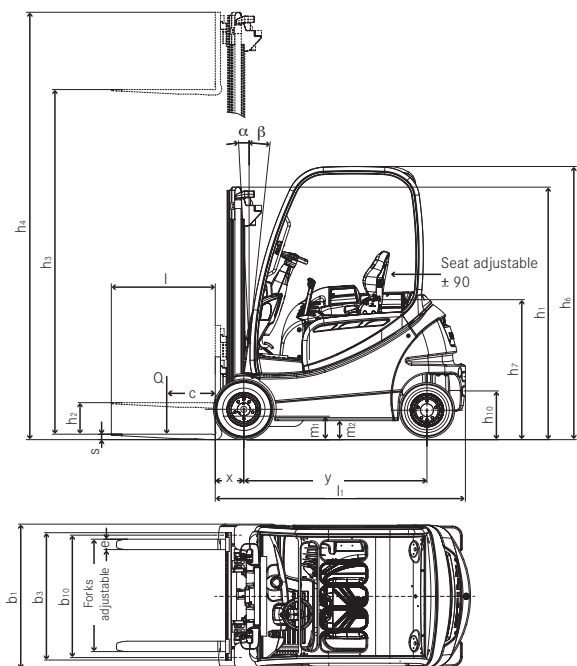

— Fork carriage
 - - - Hook-on sidshift

Capacities RX 60-16 Tele -/ HiLo mast

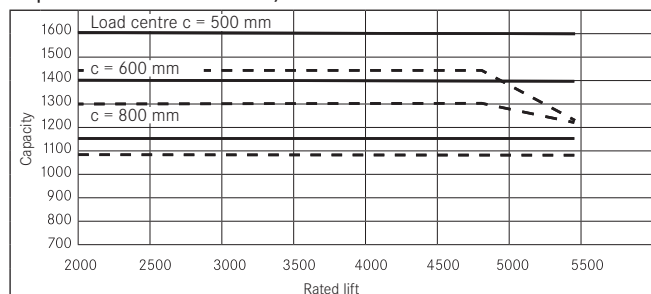

Capacities RX 60-16 Triplex mast

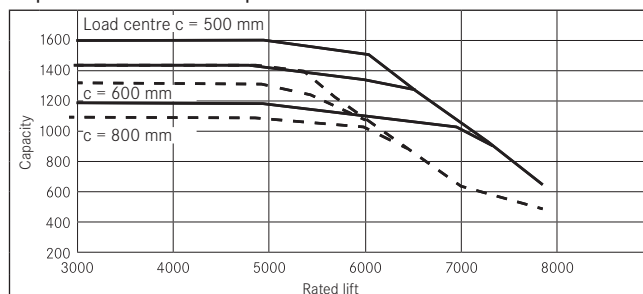

Capacities RX 60-18 Tele -/ HiLo mast

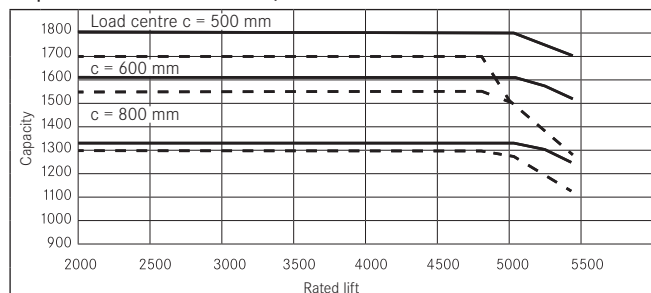

Capacities RX 60-18 Triplex mast

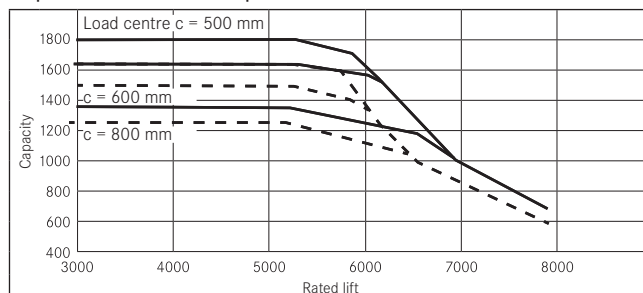

Capacities RX 60-20 Tele -/ HiLo mast

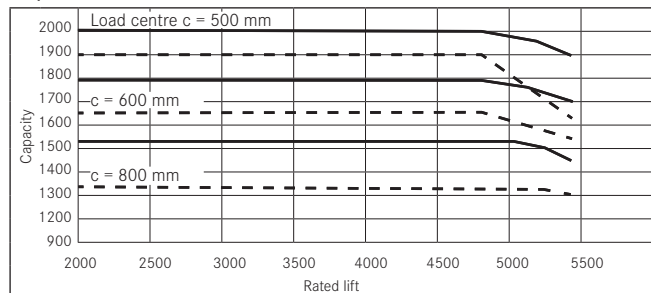

Capacities RX 60-20 Triplex mast

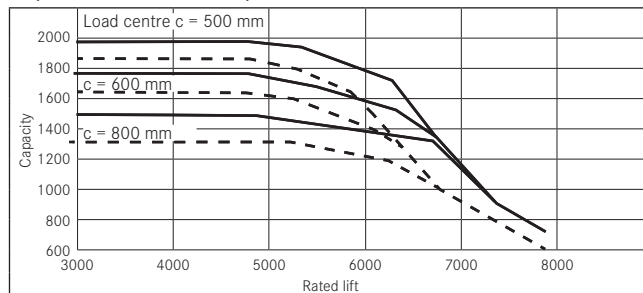

			Telescopic mast		HiLo mast	Triplex mast		
RX 60-16	Rated lift	h ₃ mm	2630 - 4430	4530 - 5430	2775 - 3975	4020 - 5520	5620 - 7870	
	Closed height	h ₁ mm	1860 - 2760	2810 - 3260	1860 - 2460	1860 - 2360	2460 - 3210	
	Free lift Form "B"	h ₂ /h ₅ mm	150	150	1230 - 1830	1230 - 1730	1830 - 2580	
	Free lift Form "A"	h ₂ /h ₅ mm	150	150	1262 - 1862	1262 - 1762	1812 - 2562	
	Overall height raised Form "B"	h ₄ mm	3280 - 5080	5180 - 6080	3425 - 4625	4670 - 6170	6270 - 8670	
	Overall height raised Form "A"	h ₄ mm	3273 - 5073	5173 - 6073	3393 - 4593	4638 - 6138	6238 - 8488	
	Forward tilt	a °			3			
	Back tilt	b °	8			6		
	Fork location centre - centre	mm			216 368 445 521 673 760			
	Greatest width	B mm	1099	1188	1099	1099	1188	
	Overall length	L ₂ mm	2108		2128			
	Load distance	x mm	355		375			
	Working aisle width	A _{st} mm	(1000 x 1200) 3439 (1200 x 800) 3638		(1000 x 1200) 3459 (1200 x 800) 3658			
	Tyres	v/h	18 x 7 - 8 / 16 x 6 - 8					
	Track	v/h mm	932/865	990/865	932/865	932/865	990/865	
	RX 60-18	Rated lift	h ₃ mm	2630 - 4430	4530 - 5430	2675 - 3875	3870 - 5370	5470 - 7720
Closed height		h ₁ mm	1860 - 2760	2810 - 3260	1860 - 2460	1860 - 2360	2460 - 3210	
Free lift Form "B"		h ₂ /h ₅ mm	150	150	1212 - 1812	1212 - 1712	1812 - 2562	
Free lift Form "A"		h ₂ /h ₅ mm	150	150	1212 - 1812	1212 - 1712	1812 - 2562	
Overall height raised Form "B"		h ₄ mm	3280 - 5080	5180 - 6080	3343 - 4543	4538 - 6038	6138 - 8389	
Overall height raised Form "A"		h ₄ mm	3273 - 5073	5173 - 6073	3343 - 4543	4538 - 6038	6138 - 8388	
Forward tilt		a °			3			
Back tilt		b °	8			6		
Fork location centre - centre		mm			216 368 445 521 673 760			
Greatest width		B mm	1138	1188	1138	1138	1188	
Overall length		L ₂ mm	2108		2128			
Load distance		x mm	355		375			
Working aisle width		A _{st} mm	(1000 x 1200) 3439 (1200 x 800) 3638		(1000 x 1200) 3459 (1200 x 800) 3658			
Tyres		v/h	200/50 - 10 / 16 x 6 - 8					
Track		v/h mm	942/865	990/865	942/865	942/865	990/865	
RX 60-20		Rated lift	h ₃ mm	2550 - 4350	4530 - 5330	2670 - 4370	3865 - 5365	5515 - 7915
	Closed height	h ₁ mm	1860 - 2760	2810 - 3210	1860 - 2710	1860 - 2360	2410 - 3210	
	Free lift Form "B"	h ₂ /h ₅ mm	150	150	1230 - 2080	1230 - 1730	1780 - 2580	
	Free lift Form "A"	h ₂ /h ₅ mm	150	150	1305 - 5155	1305 - 1805	1855 - 2655	
	Overall height raised Form "B"	h ₄ mm	3200 - 5000	5100 - 5900	3320 - 5020	4530 - 6030	6180 - 8580	
	Overall height raised Form "A"	h ₄ mm	3273 - 5073	5173 - 5825	3393 - 4693	4455 - 5955	6105 - 8505	
	Forward tilt	a °			3			
	Back tilt	b °	8			6		
	Fork location centre - centre	mm			216 368 445 521 673 760			
	Greatest width	B mm	1138	1188	1138	1138	1188	
	Overall length	L ₂ mm	2118		2140			
	Load distance	x mm	365		387			
	Working aisle width	A _{st} mm	(1000 x 1200) 3449 (1200 x 800) 3648		(1000 x 1200) 3471 (1200 x 800) 3670			
	Tyres	v/h	200/50 - 10 / 16 x 6 - 8					
	Track	v/h mm	942/865	990/865	942/865	942/865	990/865	

Drive.

The two energy efficient and noise optimised three-phase drive units on the RX 60 act on the front wheels. High traction power and driving dynamics, even on uneven ground or when climbing ramps, ensure a high turnround of goods. This provides a steady build-up of power from standstill to maximum speed. In addition, the RX 60's power boost function, whereby a momentary increase in power is provided when needed, is a particularly useful characteristic when pushing pallets or starting on ramps, for example.

The maintenance-free, efficiency-optimised three-phase drive guarantees a long battery operating life. Thanks to complete enclosure the whole drive is protected against the ingress of damaging dust and water spray, so that even applications in the worst conditions are no problem.

In addition to this, thanks to their electrical regenerative braking, the motors feed back up to 15% of the energy into the battery when the drive pedal is released, and thus increase the useful time from a battery charge by up to 1.5 hours. This means that interim battery charging or even changing is often not necessary.

The STILL controller ensures sensitive driving with optimal utilisation of energy. It also enables the truck to be held on ramps without using the maintenance-free multi-disc brakes, for greater safety and driving comfort. The power electronics are protected within the counterweight. The heat from the controller is dissipated into the counterweight over a large area. This arrangement provides very good cooling without additional fans or filters and makes the work pleasantly quiet and reliable.

Blue-Q energy optimisation.

- Activate Blue-Q energy saving mode at the push of a button.
- Energy saving due to intelligent optimisation of the drive characteristics without impairing the work process.
- Intelligently switches off electrical consumers
- A saving in energy consumption of up to 20% depending on the application and the truck's equipment.

Electrical system.

The electrical system on the RX 60 works digitally. The two separate CAN bus systems allow operation without repercussions on the drive train. This provides breakdown security. At the same time the robust controller with its two processors provides mutual monitoring for the greatest possible safety. Simple retro-fitting of other electrical units is possible through pre-prepared connections.

Mast.

Depending on the application, the Telescopic, HiLo or Triplex options offer the following:

- Telescopic: an inexpensive mast design suitable for many applications, with full visibility through the mast
- HiLo: supplements the telescopic mast with an additional central full free lift cylinder to allow high stacking under low ceilings - e.g. in containers or lorries.
- Triplex: for use where there are low doorways but high lift heights, for utilisation of warehouses right up to the roof.

Hydraulic system.

The speed of the pump motor is demand controlled and precise. It operates only when either the valve levers or steering wheel are moved, thus providing longer usage from a battery charge. The sensitive operation of the hydraulics increases working safety by positioning loads to the nearest millimetre. The hydraulics improve the energy consumption thanks to:

- High efficiency noise reduced hydraulic pump.
 - Pressure make-up valves replaced with load holding valves.
- The priority valve for the steering is directly connected to the pump so that hydraulic interfaces and hoses are not required. This guarantees a safer, cleaner operation.

Driver's compartment.

The driver's work place in the RX 60:

- The large footwell with its inclined floor plate and anti-slip covering provides quick convenient entry and exit and also a relaxed leg position when driving.
- The adjustable steering column with its small steering wheel provides an ergonomic match to the driver and reduces steering movements.
- The automotive style foot pedal arrangement can, if wished, be replaced by a double pedal arrangement, to adapt the RX 60 to whatever the driver is familiar with, for a maximum turnround of goods.
- The drive direction switch on the valve lever (hoist and lower) aids untiring concentrated work, even during long shifts, because it allows convenient changing of the drive direction without changing grip.
- Thanks to the heated fully graphic display, the time, maintenance intervals and battery state, for example, are clearly displayed even when changing from cold to warm areas of use. The whole RX 60 is subjected to constant on-board diagnosis.
- With 5 selectable drive programs the driver can match the driving characteristics of the RX 60 to the application situation or to what is personally preferred at any time. Each program can be precisely adapted to the application profile in order to achieve optimum economy and load turnround performance.
- The driver's compartment of the RX 60 provides a lot of head room even for tall drivers, and also good all round vision thanks to the large viewing panels in the roof, very slim overhead guard legs and the high seating position.

Safety.

Electrical braking when the drive pedal is released, and the fully automatic hold-on-ramp feature which works without using the brakes, plus the mechanical parking and service brake guarantees safe use at any time. Battery changes on the RX 60 are carried out using a hand pallet truck, low lift pallet truck, forklift truck or hoist. Along with the considerable saving in time compared with conventional craning of the battery, especially with cab variants, this concept minimizes the risk of crushing and damage of any sort that could occur with a heavy swinging battery.

Service.

The maintenance interval of the RX 60 is 1000 hours or 12 months. These intervals save time and maintenance costs especially in one shift operation, where the 1000 hours roughly corresponds to the number of annual operating hours and thus the maintenance and the annual examination can be carried out at the same time. Quick diagnosis by laptop computer and good accessibility of all maintenance components in conjunction with the quick availability of all necessary parts guarantee short service times and a high level of availability for the RX 60.



Your contact

STILL GmbH

Berzeliusstraße 10

D-22113 Hamburg

Telephone: +49 (0)40/73 39-2000

Telefax: +49 (0)40/73 39-2001

info@still.de

For further information please visit:

www.still.de

STILL Materials Handling Ltd.

Aston Way, Leyland

Lancashire PR26 7UX

Telephone: +44 (0)1772 644300

Telefax: +44 (0)1772 644303

info@still.co.uk

For further information please visit:

www.still.co.uk