

# KOBELCO®

*Your competitive edge.*

**SK 160<sub>LC</sub>**

**WT** 36,800lb

**HP** 112 @ 2,200 RPM

**BKT CAP** .45-1.36 cu yd



**Dynamic Acera** Hydraulic Excavator

# PRODUCTIVITY



## CAB & CONTROLS

### Large, Comfortable Cab

We've expanded the cab by 18%—making it the largest in the industry—to give the operator lots of elbowroom while ensuring that each and every control is ergonomically positioned for maximum convenience and unrivaled productivity.

Our design specialists also increased the total cab glass surface area by 36% to make the operator feel more connected with the world outside. A 2-speaker, AM/FM stereo radio, with operator pre-set station selections, is standard. Viscous silicon-filled cab mounts help eliminate the shocks and vibrations that can fatigue an operator and degrade his productivity over a long shift.

The climate-control air conditioning system can effortlessly generate an impressive 18,250 BTUs (1.52 tons) of cool air in the summer or 20,200 BTUs of heat in the winter. Any time of the year, the operator's desired temperature can be rapidly reached and maintained.

### Adjustability = Productivity

The adjustable, 7-position suspension seat lets any operator get completely comfortable regardless of size or shape. You can even move the seat forward or backward completely independent of the control lever consoles. We also designed an adjustable height feature into our pilot control levers. By adjusting the lever height to three different heights, the operator doesn't have to feel uncomfortable no matter if he is short, average or tall.

### Our NeuralNet Command System Reacts to the Operator

One of the most impressive innovations we have designed into the Dynamic Acera line is our NeuralNet Command System. Its "fuzzy logic" software works much like the technology that makes advanced military aircraft ultra-responsive to a pilot's every wish: analyzing a simple hand movement and translating it into a series of coordinated control messages. All of which makes command automatic, intuitive and extremely efficient.

### Assist Mode

This mode leverages the "fuzzy logic" of our revolutionary NeuralNet Command System, available only on Dynamic Acera excavators. During operation, constant engine RPM is maintained under varying load conditions for outstanding production efficiency. It recognizes various tasks and automatically responds, assisting the operator by adjusting the machine's response to the job's conditions. By eliminating the need for an operator to manually select from 6-10 individual work mode options per task, the Assist Mode helps him concentrate on his job, instead of pushing buttons. That leads to easier operation and more productivity — every task, every day.



DIGGING



LEVELING



SCATTERING



COMPACTING

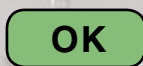

STANDBY

### Manual Mode

This default mode maximizes output for the heavy operations that require the excavator's full performance. It delivers the highest possible level of production for truck loading, mass excavation or any task requiring continuous maximum speed and power.

### Breaker Mode

This new hydraulic setting lets operators quickly adjust the pump flow rates for various auxiliary attachments, like breakers and nibbler/breakers, right from the cab. When the breaker mode is set, the flow volume is automatically controlled by whatever setting the operator chooses.

### Intelligent Total Control System (ITCS)

Rapid responsiveness is designed into the SK160LC. Our ITCS software improves productivity while ensuring that every part of this excavator feels like it is a natural extension of the operator: precise, productive and high performance.

*A graphic display on the monitor screen of the command module displays system performance, confirming each work mode setting.*

## Auto-Acceleration System

This advanced system ever-so-smoothly eases engine RPMs from 1,000 RPM to full speed in direct, proportional response to the operator's control lever movements. The result: either a very deliberate acceleration for extremely precise operations, or an instant surge to full power.

## Auto Warm-Up System

We installed an automatic warm-up system that cuts the time necessary for the engine and the hydraulic systems to reach their optimum performance levels.

## EXCEPTIONAL ENGINE



### Rock-Solid Reliable, Mitsubishi Engine Meets "Tier 2" Emission Standards

We've chosen the rock-solid, reliable Mitsubishi 4D34-TEG engine to power the Dynamic Acera SK160LC. The mighty Mitsubishi power plant generates 111 net horsepower, which is the industry's highest rating in this class. Since each Kobelco dealer also offers certified Mitsubishi support, you enjoy one-stop repair and maintenance convenience that helps you minimize downtime and keep your excavators on the job even longer. It's this kind of performance that can give you a competitive advantage over the long run. Each Mitsubishi engine comes with a tremendous support program:

- The base engine warranty, which includes parts, labor, and mileage, covers defects in materials and workmanship for 1 year/unlimited hours or 2 years/2,000 hours, whichever comes first.
- Standard, extended coverage for major components, 3 years/10,000 hours.
- Extended warranty protection can be purchased beyond the base warranty period in variable years and hours through Kobelco's Ultracare program.

## SIMPLE SERVICING

### Self-Diagnostic Capabilities and 60-Event Fault Code Memory

The best way to deal with problems is to avoid them, which is why we've built a self-diagnostic function into the computer system. It constantly gathers and displays up to 68 different service items, to help ensure small problems don't turn into big expenses. This even includes checking hydraulic pressures conveniently from the operator's cab.

We've eliminated the need to use tools, gauges or laptop computers to remotely retrieve data for recent system faults. Now up to 60 fault codes, trouble locations and hours of each event are all accessible from the cab's control console, reducing downtime and keeping your excavator operating longer.

### Friction-Inhibiting Bushings

Kobelco engineering has substantially increased both the durability and longevity of the SK160LC's boom foot, arm pivot and boom-hoist cylinders. Our design engineers came up with special, wear-resistant brass bushings fortified with graphite inserts: a long-lasting solid lubricant that inhibits friction and, along with your routine maintenance procedures, helps maximize the life of these critical components.



### Easy-Maintenance Radiator

Now you can remove the radiator without having to drain the hydraulic system, thanks to a new design that makes the radiator and oil cooler systems independent of each other. We've built in adequate space — about four inches — between the radiator and the oil cooler so it's easy to access either component for servicing. Or to just hose off any debris that has accumulated on the protective dust screen separating them.



# PERFORMANCE



## HYDRAULIC PERFORMANCE



### The Industry's Best Lift Capacity

Nothing in its class out lifts our SK160LC—front or side—and we can prove it. We've increased the SK160LC's stability, both over the front and over the side. We even strengthened our upper revolving frame and undercarriage so they could handle bigger loads, thereby increasing the machine's overall weight. Should you need it, the Heavy Lift system can be switched on for an increased capacity at close range with no time limit. These increases give the SK160LC the ability to handle large pipe, trench boxes or your most demanding jobs without breaking a sweat.

### The Industry's Highest Breakout Forces

The SK160LC excavator boasts higher arm and bucket forces than comparably equipped competitor machines in the same weight class. Furthermore, the operator can boost power by another 10% simply by pressing the Power Boost button on the right-hand control lever, unleashing the industry's highest breakout forces. Unlike competitive systems, Dynamic Acera excavators are designed to operate at their highest power levels for as long as you need them to. Bottom line: we give you all the power you need for as long as you need it.

### Swing Priority

This exclusive system automatically and instantly delivers full swing power during combined swing/arm operations—with no special switches to select—making quick work of jobs like side digging and backfilling.

### Unique Travel System

The SK160LC's travel motors give you a choice of a high-speed setting—at 3.7 mph (6.0 km/h), the world's fastest for this class—or a high torque setting—2.5 mph (4.0 km/h) for close-quarters movement. The drawbar pull has been increased to 35,100 lbs. (156 kN): the highest in its class. When the operator selects Independent Travel, one pump becomes dedicated to travel, ensuring a smooth constant propel speed without deviation during simultaneous travel/attachment operations. Delicate operations like carrying a large pipe across the job site become simple because in Independent Travel the operator can focus on the pipe without having to worry about his travel speed being affected.

### Boom and Arm Holding Valves

Operators often have to hold pipe or other heavy objects stationary while other crew members complete their work. To make sure these heavy loads don't budge, we've engineered our boom and arm holding valves to minimize attachment drift.

### Standard Auxiliary Valve with Flow Control

The functionality of the SK160LC has been enhanced to include a two-way auxiliary valve as standard, making it easy to install piping and controls for auxiliary hydraulics. So, in a matter of hours, you'll be ready to add on your attachments.

- Optional auxiliary rotation system using independent bi-directional low-flow provides for use of thumbs, twist buckets and other devices in multi-functioning applications.
- Flow to the bi-directional valve is switchable from single or double flow from the operator's cab.

Every excavator in the Dynamic Acera line features a standard auxiliary valve. The maximum flow available to the auxiliary attachment can be pre-set from inside the cab, so operators are less likely to damage your excavator or attachment through over-aggressive use.

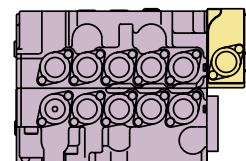

Standard  
Auxiliary  
Valve

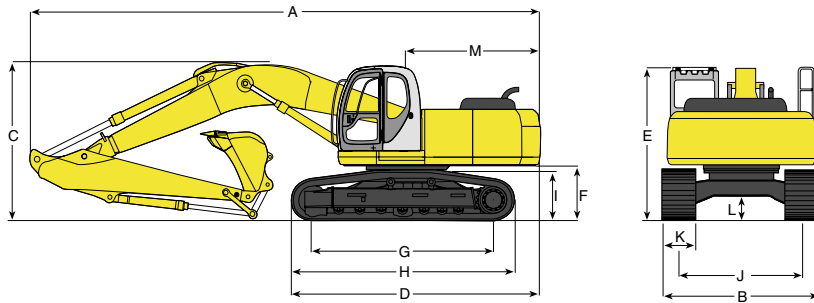

<b>DIMENSIONS</b>		Unit ft-in (m)	
<b>ARM LENGTH</b>		<b>10' 2" (3.1)</b>	<b>8' 6" (2.6)</b>
A	Overall length	28' 5" (8.65)	28' 5" (8.65)
B	Overall width (with 800 mm shoe)	8' 6" (2.59)	8' 6" (2.59)
C	Overall height (to top of boom)	9' 9" (2.96)	9' 2" (2.80)
D	Basic machine length	14' 11" (4.54)	14' 11" (4.54)
E	Overall height (to top of cab)*	9' 8" (2.95)	9' 8" (2.95)
F	Ground clearance of rear end*	3' 5" (1.03)	3' 5" (1.03)
G	Center distance of tumblers	10' 9" (3.28)	10' 9" (3.28)
H	Overall length of crawler	13' 5" (4.08)	13' 5" (4.08)
I	Crawler height at tumbler center*	37.4" (950 mm)	37.4" (950 mm)
J	Track gauge	6' 6" (1.99)	6' 6" (1.99)
K	Width of crawler shoe	23.6" (600 mm)	23.6" (600 mm)
L	Ground clearance of undercarriage*	18.9" (480 mm)	18.9" (480 mm)
M	Tail swing radius	8' 2" (2.50)	8' 2" (2.50)

\*Excludes height of grouser bar.

<b>WEIGHTS</b>		Bucket weight: 816 lbs (390 kg)	
<b>Shoe width</b>	<b>in (mm)</b>	<b>23.6" (600)</b>	<b>31.5" (800)</b>
Machine overall width ft-in (mm)		8' 6" (2,590)	9' 2" (2,790)
Ground pressure	psi (kPa)	5.51 (38)	4.35 (30)
Operating weight	lb (kg)	36,800 (16,700)	38,100 (17,300)

<b>HYDRAULIC SYSTEM</b>	
Pump	2 variable displacement
Max discharge flow	2 x 37.9 US gal/min (2 x 143.4 L/min)
Operating pressure:	
Implement	4,980 psi (34.3 MPa)
Travel	4,980 psi (34.3 MPa)
Swing	4,050 psi (27.9 MPa)
Power Boost/Heavy lift	5,470 psi (37.8 MPa)
Pilot control circuit	710 psi (4.9 MPa)
Control valves	6 spool

<b>BUCKET SELECTION CHART</b>								
<b>Bucket Duty</b>	<b>Capacity (SAE) Cubic Yard (m³)</b>		<b>Width Inches (m)</b>		<b>Bucket Weight lb (kg)</b>		<b>Arm ft-in (m)</b>	
							<b>10' 2" (3.1)</b>	<b>8' 6" (2.6)</b>
<b>General Purpose</b>	.45	(.344)	20	(.508)	1,045	(474)	H	H
	.58	(.443)	24	(.609)	1,120	(508)	H	H
	.77	(.589)	30	(.762)	1,280	(581)	M	H
	.97	(.742)	36	(.914)	1,395	(633)	L	M
	1.16	(.887)	42	(1.067)	1,550	(703)	X	L
	1.36	(1.040)	48	(1.219)	1,710	(776)	X	L
<b>Heavy Duty</b>	.45	(.344)	20	(.508)	1,120	(508)	H	H
	.58	(.443)	24	(.609)	1,200	(544)	H	H
	.77	(.589)	30	(.762)	1,365	(619)	M	H
	.97	(.742)	36	(.914)	1,485	(678)	L	M
	1.16	(.887)	42	(1.067)	1,660	(753)	X	L
<b>Severe Duty</b>	.56	(.428)	26	(.660)	1,405	(637)	H	H
	.69	(.528)	31	(.787)	1,540	(698)	M	H
	.85	(.650)	37	(.940)	1,740	(789)	L	M

H - Used with material weight up to 3,000 lbs/cu yd (1,780 kg/m³)  
M - Used with material weight up to 2,500 lbs/cu yd (1,483 kg/m³)  
L - Used with material weight up to 2,000 lbs/cu yd (1,186 kg/m³)  
X - Not recommended

# SPECS

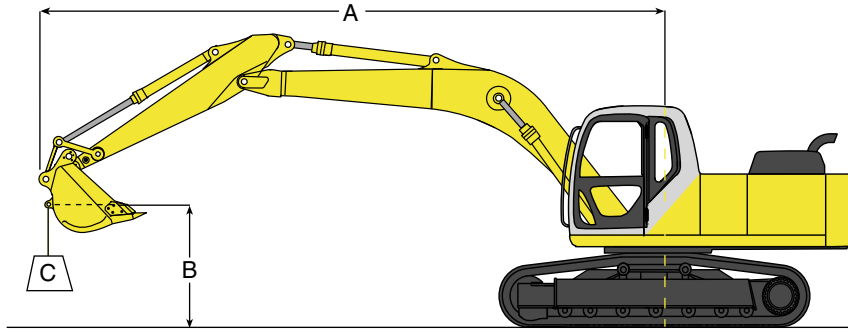

- A** Reach swing center line to bucket hook
- B** Bucket hook height above/below ground
- C** Lifting capacities in pounds and kilograms
  - Max discharge pressure:  
5,470 psi (385 kg/cm<sup>2</sup>)
  - Track shoe: 31.5" (800 mm) Triple grouser
  - Boom: 20'4" (6.2 m)

## LIFTING CAPACITIES

Shoe: 23.6" (600 mm) triple grouser

SK160 <sub>LC</sub> Standard Arm: 10' 2" (3,100 mm) Bucket: 0.68 yd <sup>3</sup> (.052 m <sup>3</sup> ) SAE heaped Bucket Weight: 816 lb (370 kg)											
A	5' (1.5 m)		10' (3.0 m)		15' (4.6 m)		20' (6.1 m)		25' (7.6 m)		
B	Over Front	Over Side/360°	Over Front	Over Side/360°	Over Front	Over Side/360°	Over Front	Over Side/360°	Over Front	Over Side/360°	C
20' (6.1 m)							*6,760 *3,060	6,680 3,030			lb kg
15' (4.6 m)							*8,660 *3,920	6,470 2,930	*4,380 *1,980	4,260 1,930	lb kg
10' (3.0 m)			*16,810 *7,620	*16,810 *7,620	*11,960 *5,420	9,710 4,400	*9,850 *4,460	6,080 2,750	*6,880 *3,120	4,100 1,860	lb kg
5' (1.5 m)			*24,010 *10,890	16,180 7,340	*14,860 *6,740	8,770 3,980	9,950 4,510	5,640 2,550	6,950 3,150	3,890 1,760	lb kg
Ground Level	*8,260 *3,740	*8,260 *3,740	*20,830 *9,440	14,960 6,780	15,120 6,850	8,100 3,670	9,550 4,330	5,280 2,390	6,750 3,060	3,720 1,680	lb kg
-5' (-1.5 m)	*13,940 *6,320	*13,940 *6,320	*24,630 *11,170	14,690 6,660	14,760 6,690	7,790 3,530	9,340 4,230	5,090 2,310			lb kg
-10' (-3.0 m)	*20,200 *9,160	*20,200 *9,160	*22,970 *10,410	14,870 6,740	14,760 6,690	7,800 3,530	9,350 4,240	5,100 2,310			lb kg
-15' (-4.6 m)	*27,100 *12,290	*27,100 *12,290	*17,050 *7,730	15,450 7,000	*11,730 *5,320	8,120 3,680					lb kg

## LIFTING CAPACITIES

Shoe: 23.6" (600 mm) triple grouser

SK160 <sub>LC</sub> Optional Arm: 8' 6" (2,600 mm) Bucket: 0.89 yd <sup>3</sup> (.063 m <sup>3</sup> ) SAE heaped Bucket Weight: 992 lb (450 kg)											
A	5' (1.5 m)		10' (3.0 m)		15' (4.6 m)		20' (6.1 m)		25' (7.6 m)		
B	Over Front	Over Side/360°	Over Front	Over Side/360°	Over Front	Over Side/360°	Over Front	Over Side/360°	Over Front	Over Side/360°	C
20' (6.1 m)							*6,190 *2,800	*6,190 *2,800			lb kg
15' (4.6 m)					*10,470 *4,750	10,260 4,650	*9,380 *4,250	6,290 2,850			lb kg
10' (3.0 m)			*19,470 *8,830	17,960 8,140	*13,060 *5,920	9,430 4,270	10,280 4,660	5,930 2,690	*4,830 *2,190	4,000 1,810	lb kg
5' (1.5 m)			*21,800 *9,890	15,620 7,080	15,670 7,110	8,570 3,880	9,840 4,460	5,540 2,510	*6,600 *2,990	3,830 1,730	lb kg
Ground Level			*20,530 *9,310	14,860 6,740	15,020 6,810	8,010 3,630	9,500 4,310	5,240 2,370			lb kg
-5' (-1.5 m)	*16,290 *7,380	*16,290 *7,380	*25,060 *11,360	14,820 6,720	14,780 6,700	7,820 3,540	9,360 4,240	5,110 2,310			lb kg
-10' (-3.0 m)	*23,830 *10,800	*23,830 *10,800	*21,220 *9,620	15,130 6,860	*14,800 *6,710	7,910 3,590					lb kg
-15' (-4.6 m)			*14,050 *6,370	*14,050 *6,370							lb kg

### Notes:

1. Do not attempt to lift or hold any load that exceeds these rated values at their specified load radii and heights. Weight of all accessories must be deducted from the above lifting capacities.
2. Lifting capacities assume a machine standing on a level, firm, and uniform supporting surface. Operator must make allowance for job conditions such as soft or uneven ground, out of level conditions, side loads, sudden stopping of loads, hazardous conditions, inexperienced personnel, weight of various other buckets, lifting slings, attachments, etc.
3. Ratings at bucket lift hook.
4. The above rated loads are in compliance with SAE Hydraulic Excavator Lift Capacity Standard J 1097. They do not exceed 87% of hydraulic lifting capacity or 75% of tipping load. Rated loads marked with an asterisk (\*) are limited by hydraulic capacity rather than tipping load.
5. Operator should be fully acquainted with the Operator's and Maintenance Manuals before operating this machine. Rules for safe operation of equipment should be followed at all times.
6. Capacities apply only to the machine as originally manufactured and normally equipped by KOBELCO Construction Machinery America LLC.

# SK160<sub>LC</sub>

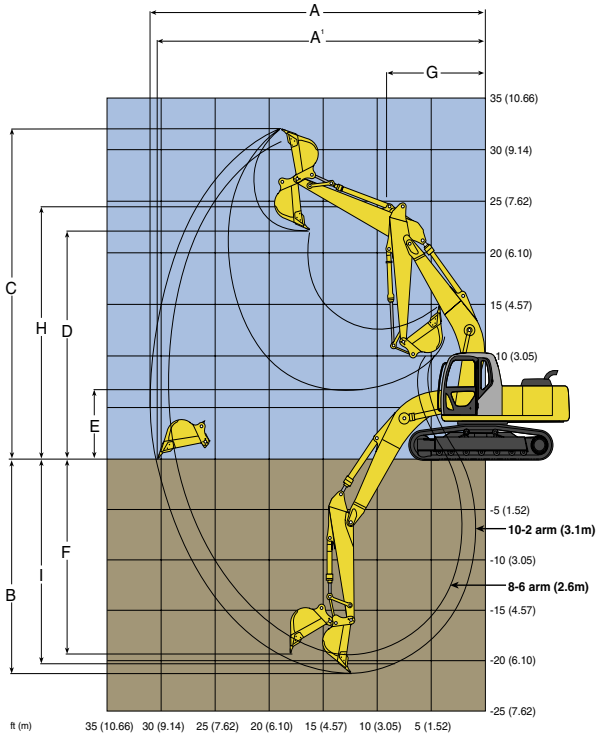

This chart is a graphic representation of the working ranges for the SK160LC equipped with a 10' 6" (3.2 m) arm.

## WORKING RANGES

Unit: ft-in (m)

ATTACHMENTS	Standard Arm	Optional Arm
	10' 2" (3.1)	8' 6" (2.6)
A Max digging reach	31' 2" (9.50)	29' 6" (8.98)
A' Max digging reach at ground level	30' 7" (9.33)	28' 11" (8.81)
B Max digging depth	21' 7" (6.57)	19' 11" (6.07)
C Max digging height	31' 7" (9.62)	30' 2" (9.20)
D Max dumping clearance	22' 10" (6.96)	21' 7" (6.57)
E Min dumping clearance	6' 9" (2.07)	8' 5" (2.57)
F Max vertical wall digging depth	19' 9" (6.02)	17' 0" (5.18)
G Min front swing radius	9' 3" (2.83)	9' 3" (2.83)
H Height at min swing radius	24' 0" (7.32)	24' 1" (7.34)
I Digging depth for 8' (2.4m) flat bottom	21' 0" (6.40)	19' 2" (5.83)

Measurements shown are for machines equipped with the 0.68 cu. yd. (0.52 m<sup>3</sup>) bucket

## DIGGING FORCE

Unit: lb (kg)

	10' 2" (3.1 m) Arm		8' 6" (2.6 m) Arm	
	SAE	ISO	SAE	ISO
Bucket digging force	*24,900 (*11,300)	*28,000 (*12,700)	24,900 (11,300)	28,000 (12,700)
Arm crowding force	*17,200 (*7,800)	*17,700 (*8,020)	19,700 (8,935)	20,275 (9,195)

\*Power boost engaged.

## PERFORMANCE

Travel speed	3.7/2.5 mph (6.0/4.0 km/h)
Swing speed	11 rpm
Gradeability	35° (70%)
Drawbar pulling force	35,100 lbs (156 kN)
Swing torque	38,722 lb-ft (52.5 kN • m)

## REFILLING CAPACITIES

Unit: US gal (liters)

Fuel tank	74.2 (281)
Hydraulic oil reservoir	37.8 (143)
Hydraulic system including oil reservoir	42.0 (159)
Cooling system	5.0 (19)
Lubrication: Engine oil	4.0 (15)

## SPECIFICATION SUMMARY

GENERAL		
Operating weight with Bucket	lb (kg)	36,800 (16,700)
Bucket Capacity Range	cu yd (m <sup>3</sup> )	.45-1.36 (.34-1.04)
ENGINE		
Make and Model	Mitsubishi	4D34-TEG
Displacement	cu in (L)	238 (3.907)
Bore and Stroke	in (mm)	4.09"x4.53" (104x115)
Horsepower SAE NET	HP(kW)@RPM	112 (82)@ 2,200
WORKING RANGES (Std. Arm)		
Standard Arm	ft-in (m)	10' 2" (3.1)
Bucket Digging Force	lb (kN)	24,900 (111)
Arm Digging Force	lb (kN)	17,200 (76.5)
Ground Level Reach	ft-in (m)	30' 7" (9.33)
Digging Depth	ft-in (m)	21' 7" (6.57)
Dumping Height	ft-in (m)	22' 10" (6.96)
Vertical Wall Digging Depth	ft-in (m)	19' 9" (6.02)
Max. Lift Capacity-Side	lb (kg)	8,100 (3,670)
@ 15' Radius & Ground Level-Front	lb (kg)	15,120 (6,850)
HYDRAULIC SYSTEM		
Hydraulic Pump	No & type	2VP+1FG
Rated Oil Flow	gpm (L/min)	2x37.9+5(2x 143.4+21)
Operating Pressure	Implement-psi (MPa)	4,980 (34.3)

Travel-psi	(MPa)	4,980 (34.3)
Swing-psi	(MPa)	4,050 (27.9)
Heavy Lift-psi	(MPa)	5,470 (37.8)
UNDERCARRIAGE		
Track Overall Length	ft-in (m)	13' 5" (4.08)
Track Overall Width w/Std. Shoe	ft-in (m)	8' 6" (2.59)
Track Shoe Selection	in (mm)	24"/32" (600/800)
Travel Speed	mph (kmh)	3.7/2.5 (6.0/4.0)
Draw Bar Pull	lb (kN)	35,100 (156)
Ground Bearing Pressure	psi (kPa)	5.51 (38)
Ground Clearance	in (mm)	19" (480)
SWING		
Swing Speed	rpm	11
Tail Swing Radius	ft-in (m)	8' 2" (2.50)
Swing Torque	lb-ft (kN • m)	38,722 (52.5)
SHIPPING DIMENSIONS		
Height	ft-in (m)	9' 9" (2.96)
Width w/Std. Shoe	ft-in (m)	8' 6" (2.59)
Length	ft-in (m)	28' 5" (8.65)
REFILL CAPACITIES		
Fuel Tank	gal (L)	74.2 (281)
Hydraulic Reservoir	gal (L)	37.8 (143)

## STANDARD EQUIPMENT

- AM/FM radio
- Arm, 10' 2" (3.1 m) with vertical ribbed rock guard, tapped blocks, breaker ready
- Audible warning system for high coolant temperature, low engine oil pressure, clogged air filter and oil replacement interval
- Auxiliary valve with flow control
- Boom: 17' 1" (5.2 m)
- Boom and arm holding (anti-drift) valves
- Breaker valve with flow control
- Cab is die formed, modular steel full-vision, sound insulated, with viscous silicon-filled mounts, windshield wiper, heater and defroster, cigarette lighter, ashtray, floor mat, cab light, control lever lock, tinted skylight with damper cylinder
- Climate control air conditioning/heating system
- Display monitor mounted on multi-function console provides status of following: aging of engine oil, fuel and hydraulic filters, system status, engine preheat, low engine oil pressure, engine coolant temperature, air cleaner restriction, battery charging, fuel level, CPU error and tachometer. Beneath monitor are switches for auto-decel, windshield washer and wiper, mode selector, one/two pump auxiliary hydraulics and swing flashers
- Double pump flow for bucket in
- Dual element air cleaner
- Electric horn
- Emergency electronic bypass
- Engine shuts down automatically for low oil pressure
- Heavy duty batteries (2 x 12 volt 136 AH)
- Heavy Lift and Power Boost
- Hydraulic track adjusters
- Independent travel
- Lifetime lubricated track rollers, idlers and sprockets
- Mitsubishi engine, model 4D34-TEG
- Mode selection:
  - Manual Mode—full performance, default mode
  - Assist Mode—simplified and useful economy mode
  - Breaker Mode—Electronic breaker flow control
- Power outlet, 24 volt to 12 volt converter
- Proportional auto accel system
- Removable cleanout screen for radiator

NOTE: Due to our policy of continual product improvement, all designs and specifications are subject to change without advance notice.

- Removable travel levers with toe tabs
- Self-lubricating bushings in boom foot and boom hoist cylinders
- Service diagnostics:
  - Computer system displays 68 service items
  - 60 event fault code memory, accessible from cab
- Starting motor (24 v/5.0 KW) 35 amp alternator
- Straight travel system
- Suspension seat—7-way adjustable
- Swing and travel automatic parking brakes
- Swing flashers recessed into counterweight. Off/on switch located on multi-function console in cab
- Swing priority (trenching system) functions automatically
- Swing shockless valve
- Track shoes: 23.6" (600 mm) semi-triple bar grouser
- Travel—two speed with automatic shift
- Two lever control for boom, arm, bucket and swing; pilot operated wrist controls and foot pedals
- Warm up function of engine and hydraulic system, functions automatically
- Work lights—three front and two rear

## OPTIONAL EQUIPMENT

- Arm: 8' 6" (2.6 m) with rock guard
- Arm: 10' 2" (3.1 m) severe duty
- Belly pan guard
- Boom: 17' 1" (5.2 m) severe duty boom
- Boom and arm load (lock) valves
- Combined one-way or two way auxiliary hydraulic piping (one or two pump) with hand or foot controls
- Control pattern changer (ISO/BHL)
- Front rain visor
- Hydraulic oil for cold or tropical environments
- Independent low-flow rotation system
- Large selection of buckets
- Single pedal travel
- Track shoe: 27.6" (700 mm) semi-triple bar grouser
- Track shoe: 31.5" (800 mm) semi-triple bar grouser
- Vandalism guards

# KOBELCO®

*Your competitive edge.*

**Kobelco Construction Machinery America LLC**

245 E. North Avenue

Carol Stream, IL 60188-2021

866-726-3396 Toll Free

630-260-4000

630-260-4304 Fax

E-mail: [digin@kobelcoamericam.com](mailto:digin@kobelcoamericam.com)

Website: [www.kobelcoamerica.com](http://www.kobelcoamerica.com)



# SK160LC