

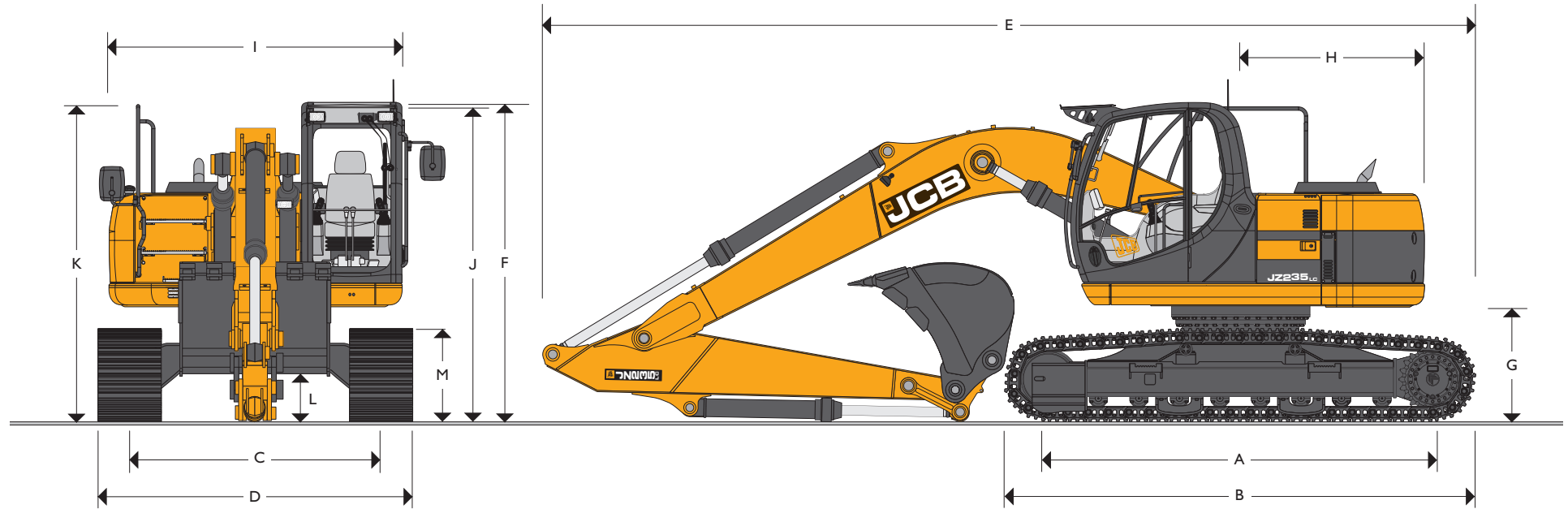

MAX. OPERATING WEIGHT: 23270 kg (51194 lb) ENGINE POWER: 128 kW (172 hp)



STATIC DIMENSIONS – JZ235 LC MONOBOOM

Dimensions in millimetres (ft-in)	LC
A Track length on ground	3660 (12-0)
B Undercarriage overall length	4460 (14-8)
C Track gauge	2390 (7-10)
D Width over tracks (500mm trackshoes)	–
D Width over tracks (600mm trackshoes)	2990 (9-10)
D Width over tracks (700mm trackshoes)	3090 (10-2)
D Width over tracks (800mm trackshoes)	3190 (10-6)
D Width over tracks (900mm trackshoes)	3290 (10-10)

Dipper lengths	1.91m (6ft 3in)	2.40m (7ft 10in)	3.0m (9ft 10in)
E Transport length with Monoboom	8980 (29-6)	8970 (29-5)	8850 (29-0)
F Transport height with Monoboom	3055 (10-0)	3060 (10-0)	3025 (9-11)

Dimensions in millimetres (ft-in)	
G Counterweight clearance	1080 (3-7)
H Tailswing radius	1680 (5-6)
I Width of superstructure	2787 (9-2)
J Height over cab	3000 (9-10)
K Height over grab rail	2970 (9-9)
L Ground clearance	486 (1-7)
M Track height	885 (2-11)



MAX. OPERATING WEIGHT: 23740 kg (52338 lb) ENGINE POWER: 128 kW (172 hp)

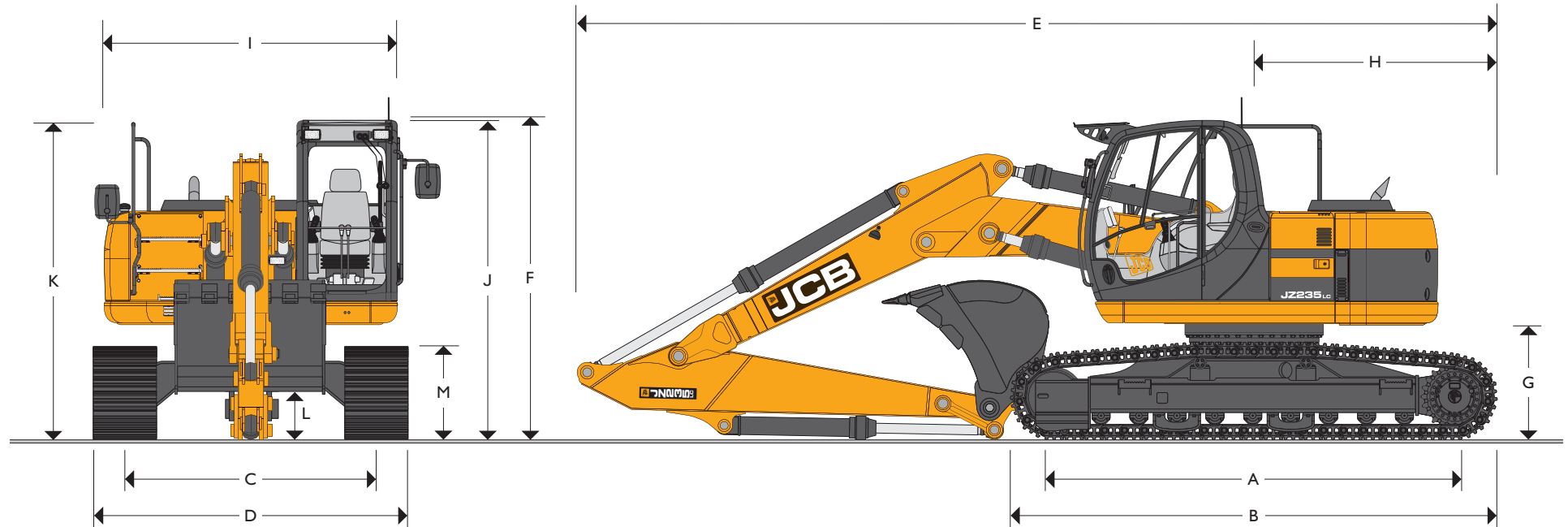

STATIC DIMENSIONS – JZ235 LC T.A.B.

Dimensions in millimetres (ft-in)	LC
A Track length on ground	3660 (12-0)
B Undercarriage overall length	4460 (14-8)
C Track gauge	2390 (7-10)
D Width over tracks (500mm trackshoes)	–
D Width over tracks (600mm trackshoes)	2990 (9-10)
D Width over tracks (700mm trackshoes)	3090 (10-2)
D Width over tracks (800mm trackshoes)	3190 (10-6)
D Width over tracks (900mm trackshoes)	3290 (10-10)

Dipper lengths	1.91m (6ft 3in)	2.40m (7ft 10in)	3.0m (9ft 10in)
E Transport length with Monoboom	8990 (29-6)	8980 (29-6)	8870 (29-1)
F Transport height with Monoboom	3065 (10-1)	3070 (10-1)	3000 (9-10)

Dimensions in millimetres (ft-in)	
G Counterweight clearance	1080 (3-7)
H Tailswing radius	1680 (5-6)
I Width of superstructure	2787 (9-2)
J Height over cab	3000 (9-10)
K Height over grab rail	2970 (9-9)
L Ground clearance	486 (1-7)
M Track height	885 (2-11)



ENGINE

Model	Isuzu 4HK1 European Tier 3 emissions compliant.
Type	Water cooled, 4-stroke, 4-cylinder in-line, common rail turbocharged diesel.
Nett power (ISO 3046- INF)	128kW (172hp) at 2000rpm.
Piston Displacement	5.193 litres (317 cu.in.).
Injection	Electronic governor.
Air Filtration	Dry element with secondary safety element and in cab warning indicator.
Cooling	Water cooler via large capacity radiator.
Starting system	24 volt – 4.5kW.
Batteries	2 x 12 volt Heavy Duty.
Alternator	24 volt 40 amp.
Refuelling pump	Electric type.

SWING SYSTEM

Swing motor	Axial piston.
Swing brake	Hydraulic braking plus automatic spring applied disc type parking brake.
Final drive	Planetary reduction.
Swing speed	9.8rpm.
Swing gear	Large diameter, internally toothed fully sealed grease bath lubricated.
Swing lock	Switchable brake in cab.

UNDERCARRIAGE

Carriage options	LC-Long Carriage.
Construction	Fully welded, "X" frame type with central bellyguarding and track motor guards. Sloping sidemembers with dirt relief holes under top rollers.
Recovery point	Front and rear.
Track type	Sealed and greased.
Track shoe options	LC – 600mm (24in), 700mm (28in), 800mm (31.5in), 900mm (36in).
Upper & lower rollers	Heat treated, sealed and lubricated.
Track adjustment	Grease cylinder type.
Track idler	Sealed and lubricated, with spring cushioned recoil. LC
No. of track guides	2 per side
No. of lower rollers	8 per side
No. of upper rollers	2 per side
No. of track shoes	49 per side

HYDRAULICS

A variable flow load sensing system with flow on demand, variable power output and servo operated, multi-function open centre control. Machine auto warm up standard – maximises performance in cold conditions.

Pumps

Main pumps	2 variable displacement axial piston type.
Maximum flow	2 x 208 L/min (2 x 46 UK GPM).
Servo pump	Gear type.
Maximum flow	20 L/min (4.4 UK GPM).
Fan drive	Gear type.

Control valve

A combined four and five spool control valve with auxiliary service spool as standard. When required twin pump flow is combined to boom and dipper services for greater speed and efficiency.

Relief valve settings

Boom/Arm/Bucket	343 bar (4975 lbf/sq.in)
Automatic power boost	373 bar (5410 lbf/sq.in)
Swing circuit	225 bar (3263 lbf/sq.in)
Travel circuit	343 bar (4975 lbf/sq.in)
Pilot control	40 bar (580 lbf/sq.in)

A separate Cushion Control valve in the servo system provides cushioning of the boom and dipper spools selection and quick warm-up of the servo system.

Hydraulic cylinders

Double acting type, with bolt-up end caps and hardened steel bearing bushes. End cushioning is fitted as standard on boom, dipper and bucket rams.

Optional hose burst check valves available for boom and dipper rams.

Filtration

The hydraulic components are protected by the highest standard of filtration to ensure long hydraulic fluid and component life.

In tank	150 micron, suction strainer.
Main return line	10 micron, fibreform element.
Plexus Bypass line	1.5 micron, paper element.
Pilot line	10 micron, paper element.
Hydraulic hammer return	10 micron, reinforced microform element.

Cooling

Cooling is provided via a full return line air blast cooler as part of a single face cooling pack in conjunction with the engine water cooler and intercooler.

TRACK DRIVE

Type	Full hydrostatic, three speed with autoshift between high and medium speed.
Travel motors	Variable swash axial piston type, fully guarded within undercarriage frame.
Final drive	Planetary reduction, bolt-on sprockets.
Service brake	Hydraulic counter balance valve to prevent overspeeding on gradients.
Park brake	Disc type, spring applied, automatic hydraulic release.
Gradeability	70% (35 deg) continuous.
Travel speed	High – 5.6 km/h (3.4 mph). Mid – 3.3 km/h (2.1 mph). Low – 2.3 km/h (1.4 mph).
Tractive effort	191.9kN (19570 kgf, 43144 lbf).



EXCAVATOR END – MONOBOOM

Monoboom available along with a choice of dipper lengths to suit the requirements of reach, dig-depth, loadover height, tearouts and site versatility. Reserve strength is built into the fully welded structures for hydraulic hammer and other arduous operations. Fabricated bucket tipping links are provided with a choice of lift points. Strong, durable construction, large cross sections and multi plate fabrications to withstand high stress applications. The 5.7m (18ft 8in) boom is designed to ensure the optimum digging envelope when matched with the three dipper lengths. Low maintenance bronze alloy bushes with graphite plugs are fitted to boom base and boom to dipper pivots resulting in 1000 hour greasing intervals at these points.

EXCAVATOR END – T.A.B.

Triple articulated boom available along with a choice of dipper lengths to suit the requirements of reach, dig-depth, loadover height, tearouts and site versatility. Reserve strength is built into the fully welded structures for hydraulic hammer and other arduous operations. Fabricated bucket tipping links are provided with a choice of lift points. Strong, durable construction, large cross sections and multi plate fabrications to withstand high stress applications. The boom is designed to ensure the optimum digging envelope when matched with the three dipper lengths.

CAB

Excellent digging, loading and positioning visibility results from the careful design of front, side and roof lights. All screens are tinted to improve in cab conditions. Fully opening front screen is very smooth to operate and as the lower screen is stored within the top screen frame it makes complete front screen opening easy, fast and convenient. Fresh air ventilation available from opening door window, opening slot in front screen and fully opening front screen. Parallelogram wash wiper for upper screen ensuring good wiped area for maximum visibility. Wiper motor is fitted in the left hand side of the roof screen so as not to affect bucket visibility when loading. Optional lower screen wiper available. Fresh air ventilation and heater with windscreen demister. Infinitely variable blower speed, temperature and recirculation control. Optional climate control. Fully adjustable deluxe suspension seat with arm rest adjustment and backrest recline. Radio with digital tuner fitted into the roof lining for maximum protection. Conveniently placed radio mute button incorporated into lower console. 12v power point and mobile phone holder built into the right hand console. Courtesy light can be operated from ground level and is illuminated for five minutes or until switched off improving operator access at night. Cab mounted roller blind protects operator from suns' glare through front or top screens.

AMS – ADVANCED MANAGEMENT SYSTEM

Four selectable working modes link the operators control movements with the engine and hydraulic systems to maximise productivity and efficiency.

A (Auto)	Up to 100% engine power and 100% flow. Gives variable power and speed depending on the operator's input, matching the demand for output and efficiency to the job. Power boost is automatically activated in this mode should hard conditions be encountered. Auto idle cuts in after a period of inactivity (between 5 and 30 seconds as set by the operator)
E (Economy)	80% engine power: 95% of hydraulic flow maximises economy while maintaining excellent output.
P (Precision)	55% engine power: 90% of hydraulic flow for fine control of grading operations.
L (Lifting)	55% engine power: 63% of hydraulic flow with permanent power boost for maximum lifting power and control.

The Auto mode allows the AMS processor to select the optimum operational performance to match the demands of the job while the three alternative modes give precise matching of application when specific tasks are undertaken.

The adjustable position monitor mounted on the front right hand pillar of the cab gives the operator a constant read out of mode, tracking range, operating temperature and a host of other information, while retaining excellent visibility of the monitor and the job being carried out.

The required flow for hammer applications can be set and stored in the AMS memory and is automatically activated whenever the hammer pedal is depressed.

A maintenance indicator warns of imminent service needs, and all servicing and basic checks can be carried out using only the in cab display.

CONTROLS

Excavator Tracks	All servo lever operated to ISO control pattern, independently adjustable to the seat. Individually servo operated by foot pedal or hand lever. Speed selection via joystick button.
Auxiliary Control isolation	Via servo operated foot pedal.
Engine speed	Via gate lock lever at cab entrance or panel switch. Dial type throttle control plus servo lever mounted one-touch idle control or separate selectable auto-idle with adjustable time delay using AMS.
Engine stop	Ignition key operated and separate shut-down button.
Horn	Operated via servo lever mounted button.



SERVICE CAPACITIES

Fuel tank	litres (UK gal)	290 (63.8)
Engine coolant	litres (UK gal)	31.8 (7.0)
Engine oil	litres (UK gal)	25.0 (5.5)
Swing reduction gear	litres (UK gal)	12.0 (2.6)
Track reduction gear (each side)	litres (UK gal)	4.7 (1.0)
Hydraulic system	litres (UK gal)	200 (44)
Hydraulic tank	litres (UK gal)	120 (26.4)

WEIGHTS AND GROUND BEARING PRESSURES

JZ235 LC – equipped with 1.14m³ bucket (760kg (1675lb), operator, full fuel tank, 600mm track shoes and 2.4m dipper.

Shoe Width	Operating Weight	Bearing Pressure
600mm (24in.)	21956kg (48405lb)	0.46kg/sq. cm. (6.54lb/sq. in.)
700mm (28in.)	22225kg (48998lb)	0.40kg/sq. cm. (5.69lb/sq. in.)
800mm (32in.)	22444kg (49591lb)	0.35kg/sq. cm. (4.98lb/sq. in.)
900mm (35in.)	22763kg (50184lb)	0.31kg/sq. cm. (4.41lb/sq. in.)

JZ235 LC T.A.B. – equipped with 1.14m³ bucket (760kg (1675lb), operator, full fuel tank, 600mm track shoes and 2.4m dipper.

Shoe Width	Operating Weight	Bearing Pressure
600mm (24in.)	22422kg (49432lb)	0.47kg/sq. cm. (6.68lb/sq. in.)
700mm (28in.)	22691kg (50025lb)	0.41kg/sq. cm. (5.83lb/sq. in.)
800mm (32in.)	22960kg (50618lb)	0.36kg/sq. cm. (5.12lb/sq. in.)
900mm (35in.)	23229kg (51211lb)	0.32kg/sq. cm. (4.55lb/sq. in.)

STANDARD / OPTIONAL EQUIPMENT

Standard Equipment: Engine fan guard; Cold start pre-heat; Auto engine warm up; Double element air cleaner; Electric refuelling pump; Heavy-duty alternator; Electrics isolator; Heavy duty batteries; Cab & engine soundproofing; Cab heater & screen demister; Tinted glass; Interior light; Coat hook; Cigarette lighter; Ashtray; Operator's storage shelf; Removable floor mat; Windscreen wash/wipe; Plug-in power socket; Automatic power boost; Auto-idle; One-touch engine speed control; Hydraulic cushion control; Boom/swing priority switch; Plexus hydraulic oil filtration; HSP pressure test points; Auxiliary pipework mounting brackets; Work lights – boom & mainframe mounted; Undercarriage belly guarding; Upper structure under covers; Swing system cover; Twin track guides; External mirrors; Handrail & non slip walk ways; Quick connect engine oil drain pipe; Front screen blind; Quick connect fuel tank drain pipe; Hinged engine under cover.

Optional Equipment: Hose burst check valves & overload warning system; Tipping link mounted lift points; General purpose buckets; Ditch/grading buckets; Quickhitch buckets; Hydraulic hammers; Auxiliary pipework (full and low flow); Climate control; Cab mounted & rear work lights; Rotating beacon; Rain guard; Biodegradeable oil; Air suspension seat with heated pad and lumbar support adjustment; lower screen wiper; Radio.

WORKING RANGE – JZ235 LC MONOBOOM

Boom length 5.70m (18ft 8in)					
Dipper length		1.91m (6ft 3in)	2.40m (7ft 10in)	3.00m (9ft 10in)	
A	Maximum digging reach	m (ft-in)	9.02 (29-7)	9.47 (31-1)	9.88 (32-5)
B	Maximum digging reach (on ground)	m (ft-in)	8.79 (28-10)	9.24 (30-4)	9.67 (31-9)
C	Maximum digging depth	m (ft-in)	5.59 (18-4)	6.08 (19-11)	6.57 (21-7)
D	Maximum digging height	m (ft-in)	10.36 (34-0)	10.70 (35-1)	10.96 (35-11)
E	Maximum dumping height	m (ft-in)	7.50 (24-7)	7.85 (25-9)	8.13 (26-8)
F	Maximum vertical wall cut depth	m (ft-in)	4.12 (13-6)	4.57 (15-0)	5.87 (19-3)
G	Minimum swing radius	m (ft-in)	2.33 (7-6)	2.37 (7-9)	2.10 (6-11)
	Bucket rotation	deg.	183°	183°	183°
	Dipper tearout (ISO 6015)	kgf (lbf)	13450 (29650)	11560 (25485)	9590 (21142)
	Dipper tearout with boost (ISO 6015)	kgf (lbf)	14610 (32210)	12550 (27670)	10410 (22950)
	Bucket tearout (ISO 6015)	kgf (lbf)	14550 (32080)	14550 (32080)	14550 (32080)
	Bucket tearout with boost (ISO 6015)	kgf (lbf)	15800 (34835)	15800 (34835)	15800 (34835)

STANDARD EXCAVATING BUCKETS

Standard excavating buckets are fully welded, heavy duty steel with hardened and sealed pivot pins.

Mono Boom length: 5.70m (18ft 8in)								
Bucket width	mm (in)	600 (24)	900 (35)	1000 (39)	1200 (47)	1350 (53)	1450 (57)	1500 (59)
Bucket capacity	m ³ (yd ³)	0.4 (0.5)	0.7 (0.9)	0.8 (1.0)	1.025 (1.3)	1.045 (1.4)	1.14 (1.5)	1.18 (2.35)
Bucket weight	kg (lb)	471 (1038)	583 (1285)	616 (1358)	695 (1532)	715 (1576)	760 (1676)	776 (1711)
Dipper length								
1.91m (6ft 3in)		○	○	○	○	○	○	○
2.40m (7ft 10in)		○	○	○	○	○	●	●
3.00m (9ft 10in)		○	○	○	○	●	●	●

○ Material weight up to 1800kg/m³ (1.35t/yd³)

● Material weight up to 1500kg/m³ (1.1t/yd³)

■ Material weight up to 1200kg/m³ (0.90t/yd³)

These recommendations are given as a guide based on typical operating conditions.

Please contact your distributor for the correct selection of buckets and attachments to suit the application.

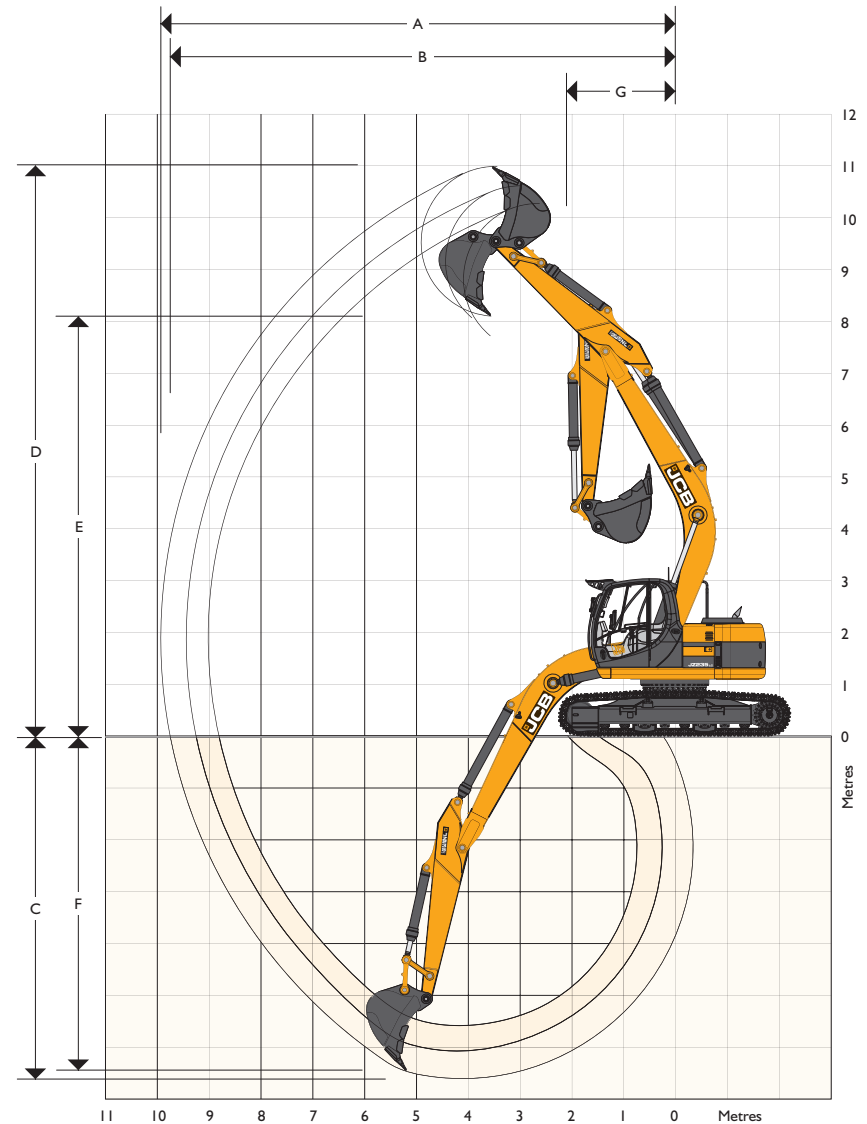

WORKING RANGE – JZ235 LC T.A.B.

Boom length 5.70m (18ft 8in)		1.91m (6ft 3in)	2.40m (7ft 10in)	3.00m (9ft 10in)	
Dipper length					
A	Maximum digging reach	m (ft-in)	9.05 (29-8)	9.50 (31-2)	9.92 (32-7)
B	Maximum digging reach (on ground)	m (ft-in)	8.80 (28-10)	9.28 (30-5)	9.72 (31-11)
C	Maximum digging depth	m (ft-in)	5.07 (16-8)	5.57 (18-3)	6.05 (19-10)
D	Maximum digging height	m (ft-in)	10.40 (34-1)	10.75 (35-3)	11.01 (36-1)
E	Maximum dumping height	m (ft-in)	7.55 (24-9)	7.91 (25-11)	8.18 (26-10)
F	Maximum vertical wall cut depth	m (ft-in)	3.29 (10-10)	3.72 (12-2)	5.07 (16-8)
G	Minimum swing radius	m (ft-in)	2.38 (7-10)	2.41 (7-11)	2.10 (6-10)
	Bucket rotation	deg.	183°	183°	183°
	Dipper tearout (ISO 6015)	kgf (lbf)	13450 (29650)	11560 (25485)	9590 (21142)
	Dipper tearout with boost (ISO 6015)	kgf (lbf)	14610 (32210)	12550 (27670)	10410 (22950)
	Bucket tearout (ISO 6015)	kgf (lbf)	14550 (32080)	14550 (32080)	14550 (32080)
	Bucket tearout with boost (ISO 6015)	kgf (lbf)	15800 (34835)	15800 (34835)	15800 (34835)

STANDARD EXCAVATING BUCKETS

Standard excavating buckets are fully welded, heavy duty steel with hardened and sealed pivot pins.

TAB length: 5.70m (18ft 8in)								
Bucket width	mm (in)	600 (24)	900 (35)	1000 (39)	1200 (47)	1350 (53)	1450 (57)	1500 (59)
Bucket capacity	m ³ (yd ³)	0.4 (0.5)	0.7 (0.9)	0.8 (1.0)	1.025 (1.3)	1.045 (1.4)	1.14 (1.5)	1.18 (2.35)
Bucket weight	kg (lb)	471 (1038)	583 (1285)	616 (1358)	695 (1532)	715 (1576)	760 (1676)	776 (1711)
Dipper length								
1.91m (6ft 3in)		○	○	○	○	○	○	○
2.40m (7ft 10in)		○	○	○	○	○	●	●
3.00m (9ft 10in)		○	○	○	●	●	■	●

○ Material weight up to 1800kg/m³ (1.35t/yd³)

● Material weight up to 1500kg/m³ (1.1t/yd³)

■ Material weight up to 1200kg/m³ (0.90t/yd³)





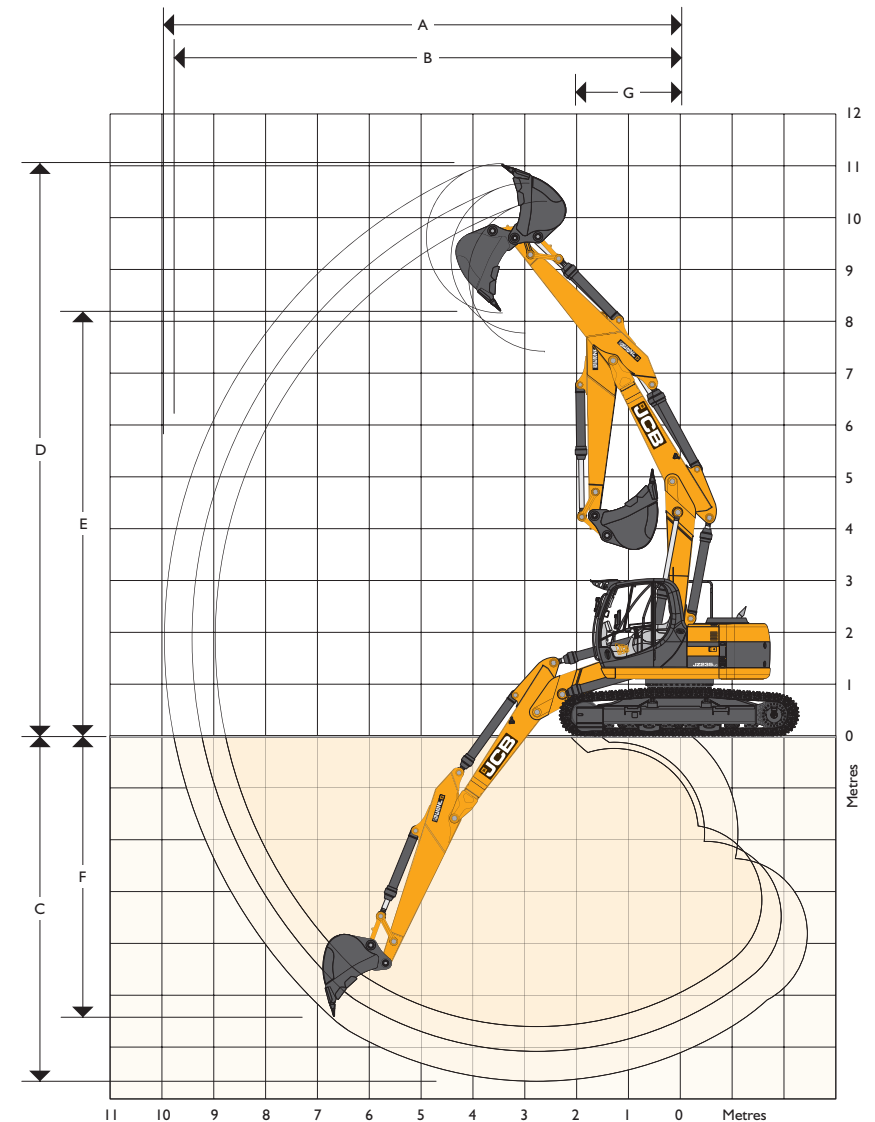







These recommendations are given as a guide based on typical operating conditions.

Please contact your distributor for the correct selection of buckets and attachments to suit the application.















LIFT CAPACITIES – Dipper length: 1.9m, Monoboam: 5.7m, Trackshoes: 600mm, No bucket.

JZ235 LC MONO

Reach	1.5m (4ft 11in)		3m (9ft 10in)		4.5m (14ft 9in)		6m (19ft 8in)		7.5m (24ft 7in)		Max. Reach		Max. Reach mm
	 kg	 kg	 kg	 kg	 kg	 kg	 kg	 kg	 kg	 kg	 kg	 kg	
Load Point Ht.	kg	kg	kg	kg	kg	kg	kg	kg	kg	kg	kg	kg	mm
7.5m (24.7ft)					7950*	7410					6870*	6820	4716
6.0m (19.8ft)			11230*	11230*	9220*	7330	7080*	4560			6350*	4440	6092
4.5m (14.9ft)			15220*	13110	10070*	6900	7200	4450			5740	3560	6886
3.0m (9.10ft)					10920*	6330	6950	4230			5140	3160	7291
1.5m (4.11ft)					10520	5910	6720	4020			4950	3020	7373
0m					9630*	5760	6580	3890			5120	3090	7142
- 1.5m (- 4.11ft)			6980*	6980*	7700*	5770	6020*	3870			5120*	3460	6566
- 3.0m (- 9.10ft)					4710*	4710*					3610*	3610*	5537

LIFT CAPACITIES – Dipper length: 2.4m, Monoboam: 5.7m, Trackshoes: 600mm, No bucket.

JZ235 LC MONO

Reach	1.5m (4ft 11in)		3m (9ft 10in)		4.5m (14ft 9in)		6m (19ft 8in)		7.5m (24ft 7in)		Max. Reach		Max. Reach mm
	 kg	 kg	 kg	 kg	 kg	 kg	 kg	 kg	 kg	 kg	 kg	 kg	
Load Point Ht.	kg	kg	kg	kg	kg	kg	kg	kg	kg	kg	kg	kg	mm
7.5m (24.7ft)					6980*	6980*					5390*	5200	5548
6.0m (19.8ft)					7250*	7250*	6530*	4590			4960*	3760	6755
4.5m (14.9ft)			11800*	11800*	8380*	6920	6920*	4450			4860*	3140	7478
3.0m (9.10ft)					9880*	6420	6930	4250	4910	3050	4570	2840	7852
1.5m (4.11ft)					10570	6020	6710	4050	4820	2970	4440	2740	7928
0m					10350	5830	6560	3920	4750	2910	4570	2800	7714
- 1.5m (- 4.11ft)			11550*	11280	10000*	5810	6520	3890			5050	3080	7185
- 3.0m (- 9.10ft)			10380*	10380*	8220*	5910	5990*	3970			5490*	3770	6260
- 4.5m (- 14.9ft)					4550*	4550*					4160*	4160*	4707













 Lift capacity front and rear.

 Lift capacity full circle.

- Notes:**
1. The above loads are in compliance with SAE and ISO Hydraulic Excavator Lift Capacity Standards.
 2. They do not exceed 87% of hydraulic lifting capacity or 75% of tipping load.
 3. Rated loads marked with an asterisk (*) are limited by hydraulic capacity rather than tipping load.

LIFT CAPACITIES – Dipper length: 3.0m, Monoboomb: 5.7m, Trackshoes: 600mm, No bucket.

JZ235 LC MONO

Reach	1.5m (4ft 11in)		3m (9ft 10in)		4.5m (14ft 9in)		6m (19ft 8in)		7.5m (24ft 7in)		Max. Reach		Max. Reach mm
	 kg	 kg	 kg	 kg	 kg	 kg	 kg	 kg	 kg	 kg	 kg	 kg	
Load Point Ht.	kg	kg	kg	kg	kg	kg	kg	kg	kg	kg	kg	kg	mm
7.5m (24.7ft)					5810*	5810*	4410*	4410*			3470*	3470*	6285
6.0m (19.8ft)					6150*	6150*	5890*	4600			3230*	3230	7372
4.5m (14.9ft)			9240*	9240*	7530*	7020	6370*	4450	4970	3100	3180*	2740	8039
3.0m (9.10ft)			12150*	12150*	9130*	6500	6920	4220	4860	3000	3260*	2500	8388
1.5m (4.11ft)					10430*	6020	6660	3990	4740	2890	3470*	2400	8459
0m			6760*	6760*	10280	5750	6480	3830	4650	2800	3860*	2450	8259
- 1.5m (- 4.11ft)	6750*	6750*	11020*	11000	10180	5670	6390	3760	4620	2770	4400	2650	7767
- 3.0m (- 9.10ft)	11320*	11320*	11980*	11160	8960*	5710	6420	3780			5230	3140	6921
- 4.5m (- 14.9ft)			8220*	8220*	6280*	5900					4620*	4390	5558















Lift capacity front and rear.















Lift capacity full circle.

- Notes:**
1. The above loads are in compliance with SAE and ISO Hydraulic Excavator Lift Capacity Standards.
 2. They do not exceed 87% of hydraulic lifting capacity or 75% of tipping load.
 3. Rated loads marked with an asterisk (*) are limited by hydraulic capacity rather than tipping load.

LIFT CAPACITIES – Dipper length: 1.9m, T.A. Boom: 5.7m, Trackshoes: 600mm, No bucket.
JZ235 LC T.A.B.

Reach	1.5m (4ft 11in)		3m (9ft 10in)		4.5m (14ft 9in)		6m (19ft 8in)		7.5m (24ft 7in)		Max. Reach		Max. Reach mm
	 kg	 kg	 kg	 kg	 kg	 kg	 kg	 kg	 kg	 kg	 kg	 kg	
Load Point Ht.	kg	kg	kg	kg	kg	kg	kg	kg	kg	kg	kg	kg	mm
7.5m (24.7ft)					7610*	7250						6410*	4719
6.0m (19.8ft)			9760*	9760*	7850*	7180	6720*	4500				5920	6095
4.5m (14.9ft)			13510*	12900	8950*	6790	7100	4400				5680	6888
3.0m (9.10ft)					10340*	6280	6880	4200				5100	7293
1.5m (4.11ft)					10470	5930	6680	4030				4930	7375
0m					10330	5820	6570	3930				5120	7144
- 1.5m (- 4.11ft)			11020*	11020*	9470*	5850	6570	3930				5780	6569
- 3.0m (- 9.10ft)			8710*	8710*	7340*	5990						5770*	5540

LIFT CAPACITIES – Dipper length: 2.4m, T.A. Boom: 5.7m, Trackshoes: 600mm, No bucket.
JZ235 LC T.A.B.

Reach	1.5m (4ft 11in)		3m (9ft 10in)		4.5m (14ft 9in)		6m (19ft 8in)		7.5m (24ft 7in)		Max. Reach		Max. Reach mm
	 kg	 kg	 kg	 kg	 kg	 kg	 kg	 kg	 kg	 kg	 kg	 kg	
Load Point Ht.	kg	kg	kg	kg	kg	kg	kg	kg	kg	kg	kg	kg	mm
7.5m (24.7ft)					7750*	7590						5740*	5548
6.0m (19.8ft)					8200*	7470	7390*	4670				5280*	6755
4.5m (14.9ft)			13880*	13810	9620*	7050	7280	4520				5060	7478
3.0m (9.10ft)					10670*	6490	7020	4280	4950	3060		4600	7852
1.5m (4.11ft)					10640	6010	6760	4050	4840	2960		4450	7928
0m					10200*	5790	6580	3900	4760	2880		4570	7714
- 1.5m (- 4.11ft)			9490*	9490*	8530*	5740	6520	3840				4840*	7185
- 3.0m (- 9.10ft)			6170*	6170*	5900*	5820	4220*	3910				3710*	6260













 Lift capacity front and rear.

 Lift capacity full circle.

- Notes:**
1. The above loads are in compliance with SAE and ISO Hydraulic Excavator Lift Capacity Standards.
 2. They do not exceed 87% of hydraulic lifting capacity or 75% of tipping load.
 3. Rated loads marked with an asterisk (*) are limited by hydraulic capacity rather than tipping load.

LIFT CAPACITIES – Dipper length: 3.0m, T.A. Boom: 5.7m, Trackshoes: 600mm, No bucket.

JZ235 LC T.A.B.

Reach	1.5m (4ft 11in)		3m (9ft 10in)		4.5m (14ft 9in)		6m (19ft 8in)		7.5m (24ft 7in)		Max. Reach		Max. Reach mm
	 kg	 kg	 kg	 kg	 kg	 kg	 kg	 kg	 kg	 kg	 kg	 kg	
Load Point Ht.	kg	kg	kg	kg	kg	kg	kg	kg	kg	kg	kg	kg	mm
7.5m (24.7ft)					5830*	5830*	4620*	4620*			3780*	3780*	6277
6.0m (19.8ft)					6070*	6070*	5960*	4700			3530*	3270	7365
4.5m (14.9ft)			8840*	8840*	8020*	7170	7220*	4530	5040	3130	3470*	2760	8033
3.0m (9.10ft)			11260*	11260*	10130*	6590	7020	4270	4920	3020	3560*	2500	8382
1.5m (4.11ft)					10710	6050	6730	4010	4780	2890	3800*	2390	8453
0m			6370*	6370*	10320	5720	6510	3820	4660	2780	4050	2420	8253
- 1.5m (- 4.11ft)			10650*	10650*	9230*	5600	6400	3720	4610	2740	4400	2620	7761
- 3.0m (- 9.10ft)			8310*	8310*	7010*	5630	5270*	3730			3900*	3100	6914
- 4.5m (- 14.9ft)					3400*	3400*					2250*	2250*	5534



Lift capacity front and rear.



Lift capacity full circle.

- Notes:**
1. The above loads are in compliance with SAE and ISO Hydraulic Excavator Lift Capacity Standards.
 2. They do not exceed 87% of hydraulic lifting capacity or 75% of tipping load.
 3. Rated loads marked with an asterisk (*) are limited by hydraulic capacity rather than tipping load.

A GLOBAL COMMITMENT TO QUALITY

JCB's total commitment to its products and customers has helped it grow from a one-man business into Britain's largest privately owned manufacturer of backhoe loaders, crawler excavators, wheeled excavators, telescopic handlers, wheeled loaders, dump trucks, rough terrain fork lifts, industrial fork lifts, mini/midi excavators, skid steer loaders and tractors.

By making constant and massive investments in the latest production technology, the JCB factories have become some of the most advanced in Europe.

By leading the field in innovative research and design, extensive testing and stringent quality control, JCB machines have become renowned all over the world for performance, value and reliability.

And with a global sales and service network of over 400 distributors and agents, the company exports over 70% of its production to all five continents.

Through setting the standards by which others are judged, JCB has become one of Britain's most impressive success stories.

