

# DYNAPAC

Part of the Atlas Copco Group

## DF45C Tracked pavers



### Technical data

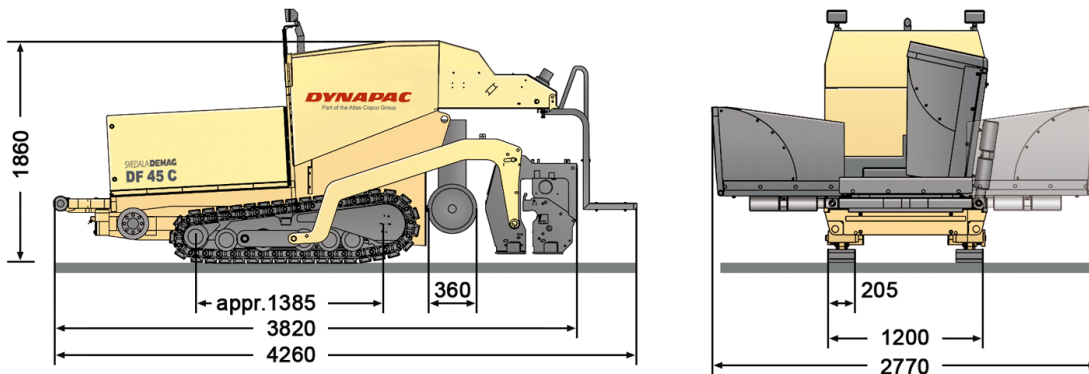

Dimensions	DF45C
Basic width	1.20 m
Working width, hydraulic extendable	2.40 m
Working width, maximum (incl. extension boxes)	3.10 m
Working width, minimum (with reducing shoe)	0.60 m
Masses	
Weight	5 t
Capacity	
Placement thickness (max)	200 mm
Theoretical placement capacity	200 t/ h
Traction	
Transport speed	5 km/ h
Working speed	0-20 m/ min
Undercarriage	
Crawler length	1,380 mm
Crawler width	205 mm
Final drive	Direct drive over transmissions
Material hopper	
Capacity	5 t
Capacity	2.30 m <sup>3</sup>
Conveyor	
Conveyor type	Single slat conveyor with center cover
Conveyor width	620 mm
Auger	
Auger diameter	360 mm
Auger control	Manual or automatically with limit switches, direction reversible
Engine	
Manufacturer	Deutz
Type	D 2011L3i
Rated power	45 hp
Rated power	32.80 kW
Rated power @	2,500 rpm
Electrical system	2 x 12 V, 60 Ah
Emissions according to	EU 3A / Tier 3

Find your local dealer at [www.dynapac.com](http://www.dynapac.com)

We reserve the right to change specifications without notice. Photos and illustrations do not always show standard versions of machines. The above information is a general description only, all informations are supplied without liability.