

CB14 CB14 xw CB14 Full Flush

Asphalt Compactors



	CB14	CB14 XW	CB14 XW	CB14 Full Flush
Cat® C1.1 Diesel Engine				
Gross power (SAEJ1995) at 2400 rpm	16.1 kW/22 hp	16.1 kW/22 hp	16.1 kW/22 hp	16.1 kW/22 hp
Net power (ISO 9249) at 2400 rpm	15.5 kW/21 hp	15.5 kW/21 hp	15.5 kW/21 hp	15.5 kW/21 hp
Compaction width	800 mm	900 mm	1000 mm	900 mm
Operating weight (with ROPS)	1620 kg	1710 kg	1840 kg	1600 kg

Caterpillar® C1.1 Engine

The C1.1 engine provides efficient power with low sound levels while meeting EU Stage II engine emission requirements.



Power. The liquid cooled Caterpillar C1.1 engine provides a gross power of 16.1 kW (22 hp) at 2400 rpm for excellent performance with low sound levels maximizing operator comfort.

Optimum Fuel Efficiency. Low engine speed at 2400 rpm provides better fuel consumption enabling more time spent working and minimum time spent refueling.

Large Cooling Package. The large cooling package with integrated water and oil cooler keeps engine temperatures low in order to maximize fuel efficiency and minimize emissions.

Serviceability. All routine service points are located to provide the best possible access for ease of service. Hydraulic test ports are provided for simplified system diagnostics and SOS ports ensure mess-free oil sampling

Vibratory System and Drum

The vibratory system provides good balance between frequency and amplitude in order to meet various job site conditions.

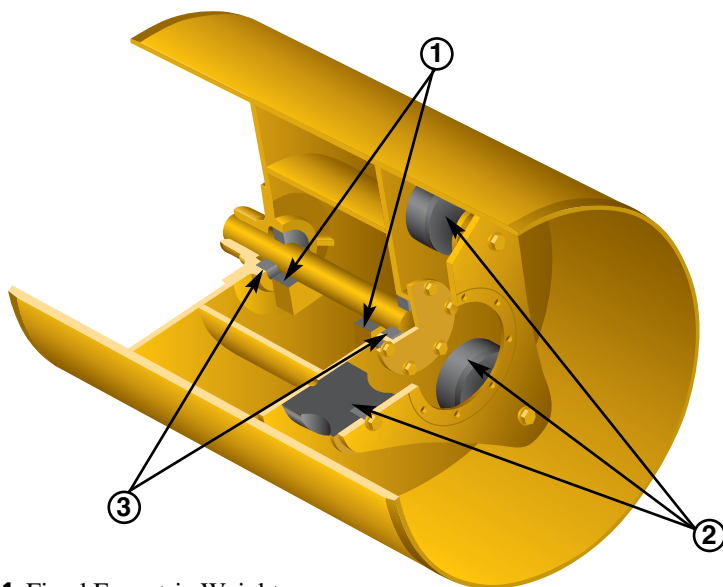

- 1 Fixed Eccentric Weights
- 2 Replaceable Rubber Mounts
- 3 Self-Lubricating Bearings

Balanced frequency and amplitude. The machines incorporate a frequency of 53.3 Hz and an amplitude of 0.4 mm in order to provide a smooth mat.

Vibration selection. Drum vibration for CB14 and CB14 XW versions can be selected for either both drums or for front drum only. Drum vibration for CB14 Full Flush is on rear drum.

Automatic Vibratory Control. The vibratory system includes an automatic start feature that activates whenever the propel lever is moved from the neutral position.

Dual Drum Drive. Continuous full drum drive traction with hydraulic motors fitted in series providing optimum tractive effort in all applications.

Rolled steel plate. Drums are constructed of rolled steel plate and are finished to reduce surface irregularities.

Versatile drum scrapers. A spring-loaded self-adjusting scraper and a fixed scraper is fitted to each drum to prevent material build up.

Operator's Station

The ergonomic operating environment with comprehensive controls and good visibility promotes day-long productivity and ease of use.



Isolated Operator's Station. The fully-isolated and roomy operator's station provides optimum operator comfort for day-long productivity. Rubber mounts on operator platform and seat reduces the vibrations transmitted to the operator, console and steering wheel.

Fully-Equipped Console. The easy-to-understand instrument panel cluster integrates a hour meter and light indicators for machine functions. The key switch includes an automatic engine pre-heat feature in order to assist in cold-weather starting. The steering wheel includes a steering knob for easy maneuverability in turns.

Smooth Operation. The hydraulic propel lever ensures a smooth and precise control which ensures the best possible surface finish.

Unobstructed visibility. Sloped engine enclosure and low profile rear end provide unobstructed visibility to the drum edges.

Foldable ROPS Option. The foldable ROPS structure folds either backwards or forwards and does not require tools.

Water Spray System

Corrosion-proof system and extended-life components provide reliable operation.



Large water tank fill port with removable filter

Water Tank. A 150 liter high-capacity polyethylene water tank is protected within the machine frame. The tank design provides extended operation and a single fill point.

Efficient Water Coverage. Corrosion-free plastic spray bars fed by the standard gravity fed water system provide optimum water coverage on both drums.

Large Water Tank Fill and Drain. The large water tank fill port and grouped drains allow the system to be filled and drained within minutes.

Pressurized Water Spray System Option. Three-mode spray function and pressurized water spray system option with constant or intermittent capabilities provides extended operation between refills.

Water Filtration. Triple water filtration reduces machine downtime caused by system clogs.

Spray Nozzles and Filters. The water spray nozzles, included with the pressurized water spray system option, and filters are easily removed by hand without the need of special tools.

Extra Wide Drums – CB14 XW

Wider drums on the CB14 XW provide increased production results on larger job sites.



Increased Production. The CB14 XW is available in two versions; 900 mm wide drums and 1000 mm wide drums. These two versions enable increased mat width coverage in fewer overlapping passes.

Offset Drum Enhances Versatility – CB14 Full Flush

An offset front driving drum provides flush compaction for increased machine versatility.

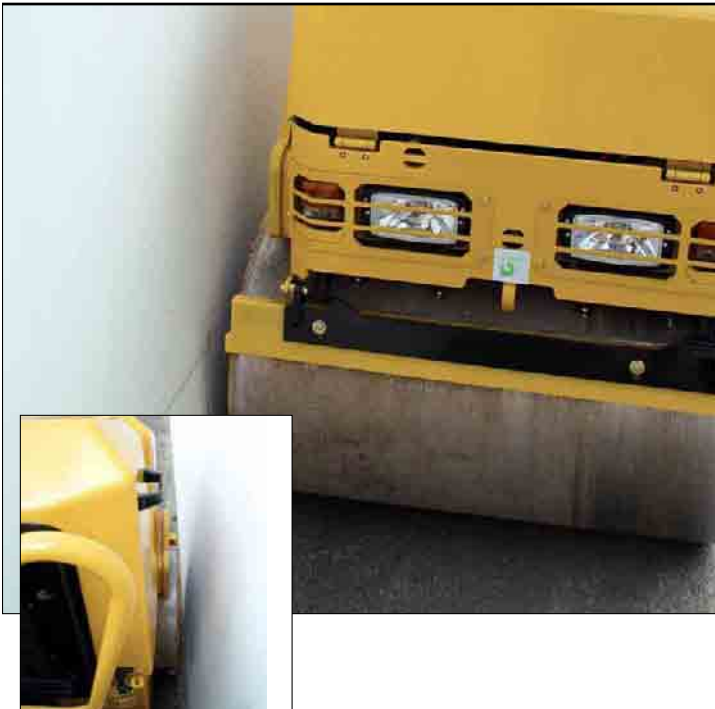

Full flush compaction. The front 900 mm offset driving drum allows the compactor to operate against a wall, curb or other vertical obstructions achieving complete compaction coverage.

Visibility. Optimum visibility to the front offset drum edge provides the operator with complete control when working close to vertical obstructions or barriers.

Serviceability

The CB14, CB 14 XW and CB14 Full Flush provide the reliability and serviceability that you've come to expect from Caterpillar.



Engine Enclosure. Fiberglass engine enclosure pivots upward and locks open with a prop rod.

Vibe Lubrication. Oil-bath lubrication of eccentric weight bearings reduces routine maintenance to 1 year/500 hour intervals.

Service Points. External engine components, hydraulics and routine service points are clustered in easy-to-access locations.

Oils. Extended-life oils increase maintenance intervals for the vibratory system, hydraulic system and engine oil. Engine oil change interval has been extended to 500 hours.

Drains. Remote-mounted drains for engine, hydraulic oil and cooling system provide simplified collection of fluids.

Hydraulic Test Ports. Quick-connect hydraulic test ports simplify system diagnosis.

Electrical System. Electrical wiring is color-coded and numbered for simple troubleshooting. Nylon-braided wrap and all-weather connectors ensure electrical system integrity.

Engine

Four-stroke cycle, three cylinder Caterpillar C1.1 diesel engine meets EU directive 97/68/EC Stage II emission requirements.

Gross Power	2400 rpm
SAE J1995	16.1 kW/22 hp
Net Power	2400 rpm
ISO 9249	15.5 kW/21 hp
80/1269/EEC	15.5 kW/21 hp
Bore	77 mm
Stroke	81 mm
Displacement	1131 cm ³

- All engine horsepower are metric including front cover.
- Net power ratings are tested at the reference conditions for the specified standard.
- Net power advertised is the power available at the flywheel when the engine is equipped with fan, air cleaner, muffler and alternator.
- Dual-element, dry-type air cleaner with visual restriction indicator.

Transmission

- Dual hydrostatic drum drive with hydraulic motors fitted in series.
- Variable-displacement piston-type pump supplies pressure flow to fixed-displacement hydraulic motors that drive the front and rear drums.
- A propel lever located at the operator's station provides smooth control of the infinitely variable speeds in both forward and reverse.

Speed

Forward and reverse 0-8.5 km/h

Steering

Priority-demand hydraulic power-assist steering system provides smooth, firm machine handling.

Minimum turning radius

Inside drum edge	mm
CB14	2650
CB14 XW (900 mm)	2625
CB14 XW (1000 mm)	2600
CB14 Full Flush	L2650/R2600
Outside drum edge	
CB14	3050
CB14 XW (900 mm)	3075
CB14 XW (1000 mm)	3100
CB14 Full Flush	L3100/R3050
Steering angle	32°

Instrumentation

- The control console includes: steering wheel with knob, roading light switch, horn, water spray system switch, vibratory drum selector switch, turn signals, hazard flasher control, parking brake, engine ignition with preheat and working light switch (if equipped).
- The instrument panel cluster integrates the service hour meter and also the light indicators for: working lights (if equipped), water spray, roading lights, parking brake, engine coolant temperature, alternator, engine oil temperature, vibratory system, engine preheat and turn signals.
- The vibratory system is actuated with a switch on the top of the propel lever.
- When the vibratory system is activated, a vibration indicator light illuminates.
- The vibratory system includes an automatic start feature that activates whenever the propel lever is moved from the neutral position and deactivates when moved into neutral.
- The engine throttle control is operated via a lever positioned to the right side of the steering column.
- The control console, the hood and the literature compartment are equipped with lockable covers.

Water Spray System

- The standard gravity fed water spray system is equipped with a plastic spray bar for corrosion resistance. The water tank is reinforced polyethylene.
- The optional pressurized water spray system is equipped with spray nozzles and an electric water pump that provides either continuous or intermittent spray. Intermittent spray setting increases spray time by 50 percent over continuous setting.
- Triple filtration includes a filter on the tank fill spout, an in-line filter at the water pump and filters on each spray nozzle. Spray nozzles with drop stop feature are easily removed without tools for cleaning (if equipped with the optional pressurized water spray system).
- Four spray nozzles are fitted over the rear drum and three nozzles over the front drum for optimum water coverage (if equipped with the optional pressurized water spray system).

Frame

Fabricated from heavy gauge steel plate and rolled sections. The two sections are joined by two hardened steel pins that are supported by heavy-duty roller bearings. A vertical pin provides a $\pm 32^\circ$ steering angle and the frame/yoke provides $\pm 8^\circ$ oscillation for a smooth ride and uniform drum loading.

Electrical System

The 12-volt electrical system includes one maintenance-free Cat[®] battery and color-coded and numbered wiring wrapped in nylon braid. The system includes a 65-amp alternator.

Brakes

Brake systems meet EN500-4. The braking system will automatically engage if a pressure drop in the hydraulic system occurs.

Service

Closed-loop hydrostatic drive system provides dynamic braking during machine operation.

Secondary and Parking

Spring-applied/hydraulically released brake on front and rear drums. Actuated by switch on console or automatically when pressure is lost in brake circuit or when engine is shut off.

Optional Equipment

Back-up Alarm
Roll Over Protective Structure (ROPS)
Foldable ROPS
Pressurized Water Spray
Working Light Package
Roading and Working Light Package
Lights Protection
Rotating Beacon
Battery Disconnect Switch
Suspension Seat with Seat Switch
Spark Arrestor Muffler
Single Lifting Point
Biodegradable Hydraulic Oil

Compaction Characteristics

Vibration selections

CB14	Front or both
CB14 XW	Front or both
CB14 Full Flush	Rear
Eccentric weight drive	Hydraulic
Frequency	53 Hz

Nominal amplitude

CB14	0.4 mm
CB14 XW (900 mm)	0.38 mm
CB14 XW (1000 mm)	0.4 mm
CB14 Full Flush	0.4 mm

Centrifugal force per drum

CB14	10.3 kN
CB14 XW (900 mm)	10.3 kN
CB14 XW (1000 mm)	11.4 kN
CB14 Full Flush	10.3 kN

Static linear load

CB14	10.1 kg/cm
CB14 XW (900 mm)	9.5 kg/cm
CB14 XW (1000 mm)	9.2 kg/cm
CB14 Full Flush	9.4 kg/cm

Dimensions

All dimensions are approximate.

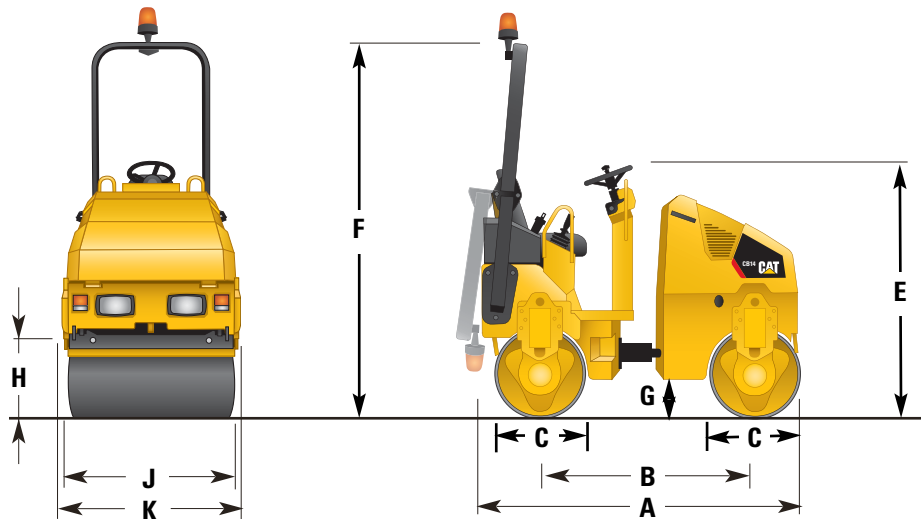

	CB14	CB14 XW (900/1000 mm)	CB14 Full Flush
	mm	mm	mm
A Length	2050	2050	2050
B Wheelbase	1300	1300	1300
C Drum diameter	575	575	575
Drum shell thickness	10	10	10
E Height at steering wheel	1630	1630	1630
F Height at ROPS	2395	2395	2395
G Ground clearance	250	250	250
H Curb clearance	370	370	370/*
J Compaction width	800	900/1000	900
K Machine width	884	984/1084	960

* Offset drum on right side

Service Refill Capacities

	Liters
Fuel Tank	30
Engine oil with filter	4.9
Hydraulic fluid tank	34
Water spray system	150

Weights

Operating weights include lubricants, 80 kg operator, full fuel tank, full hydraulic system and half-full water tanks (all weights are approximate).

	CB14	CB14 XW (900/1000 mm)	CB14 Full Flush
	kg	kg	kg
Operating weight with ROPS	1620	1710/1840	1600
at front drum	740	785/840	720
at rear drum	880	925/1000	880

CB14, CB14 XW and CB14 Full Flush Asphalt Compactors

For more complete information on Cat products, dealer services, and industry solutions, visit us on the web at www.cat.com

Materials and specifications are subject to change without notice. Featured machines in photos may include additional equipment. See your Caterpillar dealer for available options.

© 2007 Caterpillar -- All rights reserved

HEHH3561 (02/2007) hr

CAT, CATERPILLAR, their respective logos, "Caterpillar Yellow" and the POWER EDGE trade dress as well as corporate and product identity used herein, are trademarks of Caterpillar and may not be used without permission.

CATERPILLAR[®]