

# Hiab XS 1055

## Capacity 90 tm



# Hiab XS 1055 Basic data

<b>Technical data</b>	<b>EP-6 HiPro</b>	<b>E-6 HiPro</b>	<b>E-8 HiPro*</b>	<b>E-10 HiPro</b>
Max. lifting capacity (kNm)	826	820	804	796
Outreach - hydraulic extensions (m)	16.5	15.3	19.6	24.0
Outreach - manual extensions (m)	-	-	-	-
Outreach - jib (m)	-	25.0	29.2	-
Outreach / lifting capacity (m / kg)	4.7 / 18000	4.4 / 18000	4.4 / 18000	4.4 / 18000
	6.2 / 13300	5.9 / 13900	6.1 / 13000	6.3 / 12300
	8.0 / 10100	7.6 / 10500	7.8 / 9800	8.0 / 9300
	9.9 / 8000	9.3 / 8400	9.5 / 7800	9.7 / 7300
	11.9 / 6600	11.2 / 6900	11.4 / 6300	11.6 / 5800
	14.1 / 5500	13.2 / 5800	13.4 / 5200	13.6 / 4750
	16.3 / 4750	15.1 / 5000	15.3 / 4450	15.5 / 4050
	-	-	17.4 / 3850	17.6 / 3500
	-	-	19.4 / 3450	19.6 / 3050
	-	-	-	21.8 / 2720
	-	-	-	23.8 / 2500
Outreach / lifting capacity, with Jib (m / kg)	-	18.4 / 2920	22.5 / 1780	-
	-	19.4 / 2740	23.5 / 1680	-
	-	20.7 / 2540	24.8 / 1560	-
	-	21.9 / 2320	26.0 / 1480	-
	-	23.4 / 1840	27.5 / 1380	-
	-	24.9 / 1520	29.0 / 1240	-
	-	26.4 / 1280**	30.5 / 1020**	-
Slewing angle	∞	∞	∞	∞
Height in folded position (mm)	2587	2507	2507	2602
Width in folded position (mm)	2504	2500	2500	2505
Installation space needed (mm)	1626	1665	1730	1730
Weight - "standard" crane without stabilizers (kg)	7010	7260	7770	8150
Weight - Jib (kg)	-	1390	1370	-
Weight - manual extension for Jib (kg)	-	50	50	-
Frame attachments (kg)	130	130	130	130
Weight - support leg equipment 9 m span (kg)	1220 - 1390	1220 - 1390	1220 - 1390	1220 - 1390

\* Jib with Dual Capacity (JDC)

\*\* With jib + 1 man. extension

**Hiab XS 1055 E-10 HiPro**

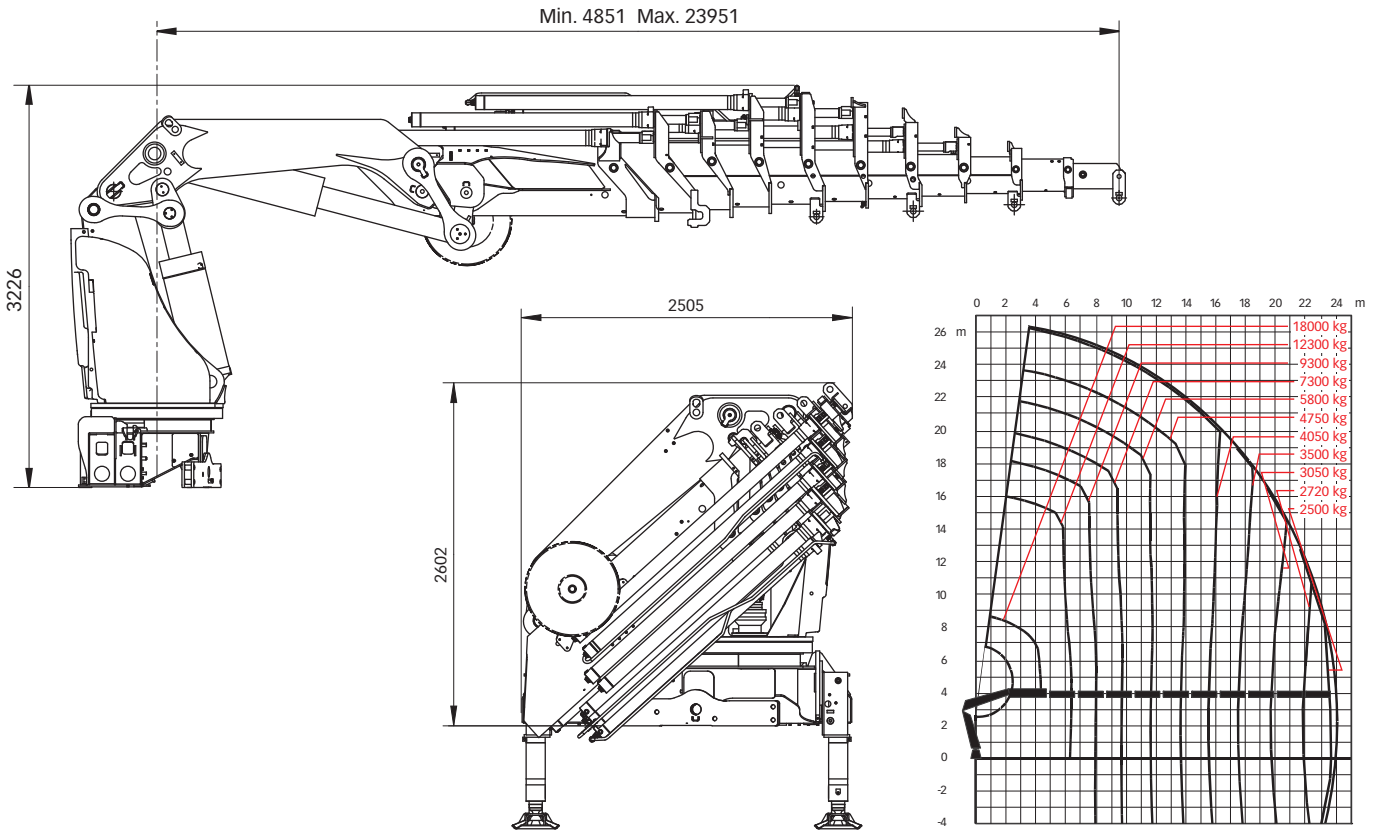

**Hiab XS 1055 E-8 HiPro jib 175X-5 JDC**

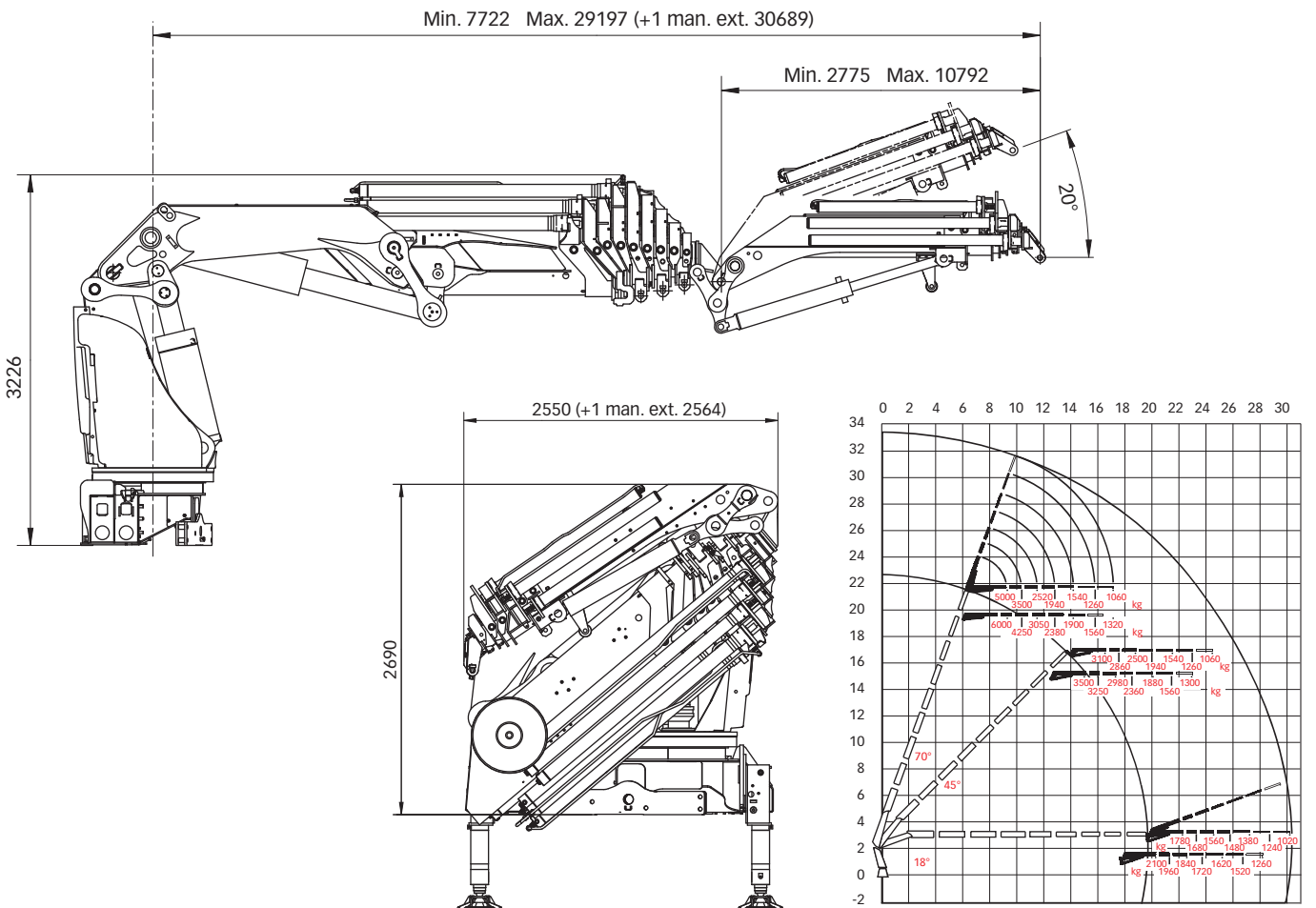

**Disclaimer.** Hiab cranes have been built to meet the highest standards of safety and service life and have been thoroughly tested. Strength calculations for this model have been carried out in accordance with EN13001 in fatigue class S0. Cargotec's certified Quality Assurance System complies with ISO 9001. Some of the items in our literature may be extra equipment. Certain applications may require an official permit. We reserve the right to change technical specifications without prior notice. Hiab cranes produced for EU-countries are CE-marked and comply with the European Standard EN 12999.

**Cargotec** improves the efficiency of cargo flows by offering solutions for the loading and unloading of goods on land and at sea – wherever cargo is on the move. Cargotec's main daughter brands for cargo handling Hiab, Kalmar and MacGregor are global market leaders in their fields. [www.cargotec.com](http://www.cargotec.com)

