

# REACH TRUCK



INDUSTRIAL EQUIPMENT

REACH NEW HEIGHTS

2500 - 4500 LBS.

SPECIFICATIONS



9BRU18-23 | 9BDRU13-15

CLASS  
2

ELECTRIC MOTOR NARROW AISLE

ToyotaForklift.com



## REACH TRUCK

CAPACITY  
**2500 - 4500 LBS.**

WHEELBASE  
**57 - 67 IN.**

LOAD CENTER  
**24 IN.**

### INDUSTRIES



Cold Storage



Distribution



Factory



Food Processing



Food Storage



General Manufacturing



General Warehousing



Retail

## STANDARD FEATURES

### PERFORMANCE

- 24-Volt electrical system<sup>1</sup>
- 36-Volt electrical system
- Variable-speed lift and lowering
- Electric power-steering motor
- Two-speed reach/retract
- Current-controlled proportional valve
- Multifunction control handle
- Interactive digital display panel
  - Multifunctional hour meter
  - Time & date display
  - Programmable travel, acceleration, lift/lower speeds, reach/retract
  - Fault code memory
- AC-powered drive system with torque control
- AC hydraulic system
- Lowering flow limiter
- Lift system relief valve
- UL-approved type “E” rating

### OPERABILITY

- 180° electronic power steering
- Auto position hold
- Flexible dock stance operator compartment
- Wide-view 3-stage mast (FSV)
- Hydraulic cushioned mast staging
- Hydraulic cushioned retract system
- Hydraulic fork deceleration at floor level
- Lift slow down at max lift
- 33" - 50" base leg openings (ID)
  - In 1" increments<sup>2,3</sup>
- Polyurethane drive tire (13.5" dia. x 6")
- Tandem articulated, bolt-on polyurethane load wheels (5" x 3.63")
- Polyurethane caster wheel (dual)
- Proportional handle plugging
- Tapered toe box (5" x 3.63") (9BDRU13, 9BDRU15 only)
- Universal operator presence pedal with cushioned pad
- Electric disc brake
- Regenerative braking
- Ventilated tractor compartment with high-capacity cooling fan
- 48" tilting load backrest extension (5° forward/3° backward)<sup>6</sup>
- ITA Class II hook-type carriage (32" wide)
- Anti-static ground strap
- Adjustable speed limit above Free-Lift (0 - 3.5 mph)
- Forks: 42" x 1.75" x 4"
  - 42" x 1.5" x 4" on 9BRU18

### ERGONOMICS

- Bubble-cushioned padded floor and brake pedal
- Ergonomically angled floorboard
- Integrated clipboard, amenities tray and cup holder
- High-visibility overhead guard
- Safety glass mast guard<sup>4</sup>
- Comfort-padded lean points
- Cushioned knee pad

### SERVICEABILITY

- Battery compartment rollers
- Adjustable battery retaining gates
- SB350 red connector<sup>5</sup>
- SB350 gray connector<sup>6</sup>
- Battery discharge indicator with lift interrupt
- Self-diagnostics
- Built-in analyzer
- Over temperature indicator with protection
  - on drive & lift motor
- Emergency power disconnect switch
- Electric horn
- Key switch
- Self-adjusting electric disc brake
- Enclosed battery compartment
  - 14.5" x 38.62" x 31"<sup>11</sup>
  - 16.5" x 38.62" x 31"<sup>11</sup>
  - 18.5" x 38.62" x 31"<sup>17</sup>
  - 21.5" x 38.62" x 31"<sup>18</sup>

## OPTIONAL EQUIPMENT

- Dock stance package
  - Tall operator backrest
  - Third overhead guard pillar
- Battery side gate interlock switches
- Poly drive tire options
- Poly load wheel options
- Load weight display (not legal for trade)
- Operator compartment fan
- LED overhead guard-mounted worklights
- LED operator compartment dome light
- LED strobe light options (top mounted)
- Directional travel alarm options
- Fire extinguisher
- Mast lift limit switch with bypass
- Height & tilt indicator
- Acculaser
- Reach interlock switch
- RF bracket options with 2 amp power hookup
- Keyless on/off switch
- Operator PIN code entry system
- Optional battery connector colors
- UL-approved type “EE” rating
- Cold storage/freezer conditioning

<sup>1</sup> Only available on 9BRU18 & 9BDRU13.

<sup>2</sup> Specify base leg opening size (inside dimension).

<sup>3</sup> When ordering the truck without a sideshifter, in order to straddle the load, ensure that the base leg opening size (ID) is at least 2" greater than the load width.

<sup>4</sup> When the cold storage/freezer conditioning option is ordered, the safety glass mast guard is replaced with the wire mesh mast guard.

<sup>5</sup> Standard on 24-Volt trucks.

<sup>6</sup> Standard on 36-Volt trucks.

<sup>7</sup> Only available on 9BRU18, 9BRU23 & 9BDRU15.

<sup>8</sup> Only available on 9BRU23 & 9BDRU15.

**Note:** Please check with your local Toyota sales professional for additional options.

TRUCK SPECIFICATIONS

MODEL NUMBERS / BATTERY COMPARTMENT SIZE

| GENERAL DATA   |                       |              | 9BRU18 / 14.5                  |                   | 9BRU18 / 16.5                  |                   | 9BRU18 / 18.5                  |  |
|--|-----------------------|--------------|--------------------------------|-------------------|--------------------------------|-------------------|--------------------------------|--|
| Type / Load Capacity <sup>1</sup> (with 24" load center) | lb (kg)               |              | Single Reach / 3500 (1580)     |                   | Single Reach / 3500 (1580)     |                   | Single Reach / 3500 (1580)     |  |
| Total Weight (without battery)                           | lb (kg)               |              | 6100 (2767)                    |                   | 6150 (2790)                    |                   | 6200 (2812)                    |  |
| Operator Position  |                       |              | Stand-Up Rider                 |                   | Stand-Up Rider                 |                   | Stand-Up Rider                 |  |
| EXTERIOR DIMENSIONS                                      |                       |              | 9BRU18 / 14.5                  |                   | 9BRU18 / 16.5                  |                   | 9BRU18 / 18.5                  |  |
| <b>A</b> Battery Compartment Size <sup>2</sup> (length)  | in (mm)               |              | 14.5 (368)                     |                   | 16.5 (419)                     |                   | 18.5 (470)                     |  |
| <b>B</b> Maximum Fork Height <sup>1</sup>                | in (mm)               |              | 271 (6883)                     |                   | 301 (7645)                     |                   | 301 (7645)                     |  |
| <b>C</b> Mast Lowered Height                             | in (mm)               |              | 119 (3022)                     |                   | 131 (3327)                     |                   | 131 (3327)                     |  |
| <b>D</b> Mast Extended Height                            | in (mm)               |              | 319 (8103)                     |                   | 319 (8103)                     |                   | 319 (8103)                     |  |
| <b>E</b> Free-Lift                                       | in (mm)               |              | 76 (1930)                      |                   | 76 (1930)                      |                   | 76 (1930)                      |  |
| <b>F</b> Wheelbase                                       | in (mm)               |              | 57.1 (1450)                    |                   | 59.1 (1501)                    |                   | 61.1 (1552)                    |  |
| <b>G</b> Head Length (length to fork face)               | in (mm)               |              | 55.3 (1405)                    |                   | 57.3 (1430)                    |                   | 59.3 (1506)                    |  |
| <b>H</b> Truck Length (length to end of base legs)       | in (mm)               |              | 76.2 (1935)                    |                   | 78.2 (1986)                    |                   | 80.2 (2037)                    |  |
| <b>I</b> Power Unit Length                               | in (mm)               |              | 35.5 (902)                     |                   | 37.5 (953)                     |                   | 39.5 (1003)                    |  |
| <b>J</b> Power Unit Width                                | in (mm)               |              | 42.5 (1080)                    |                   | 42.5 (1080)                    |                   | 42.5 (1080)                    |  |
| <b>K</b> Power Unit Height <sup>3</sup>                  | in (mm)               |              | 51.5 (1308)                    |                   | 51.5 (1308)                    |                   | 51.5 (1308)                    |  |
| <b>L</b> Carriage Width                                  | in (mm)               |              | 32 (813)                       |                   | 32 (813)                       |                   | 32 (813)                       |  |
| <b>M</b> Load Backrest Height                            | in (mm)               |              | 48 (1220)                      |                   | 48 (1220)                      |                   | 48 (1220)                      |  |
| <b>N</b> Tilt Range (forward / backward)                 | deg                   |              | 3 / 4.5                        |                   | 3 / 4.5                        |                   | 3 / 4.5                        |  |
| <b>O</b> Overhead Guard Height <sup>4</sup>              | in (mm)               |              | 90.81 (2307)                   |                   | 90.81 (2307)                   |                   | 90.81 (2307)                   |  |
| <b>P</b> Base Legs Opening (inside dimensions)           | in (mm)               |              | 33 - 50 (838 - 1270)           |                   | 33 - 50 (838 - 1270)           |                   | 33 - 50 (838 - 1270)           |  |
| <b>Q</b> Base Legs Overall Width (outside dimensions)    | in (mm)               |              | 44 - 61 (1118 - 1550)          |                   | 44 - 61 (1118 - 1550)          |                   | 44 - 61 (1118 - 1550)          |  |
| Base Leg Width   | in (mm)               |              | 5.5 (140)                      |                   | 5.5 (140)                      |                   | 5.5 (140)                      |  |
| Fork Size (T x W x L)                                    | in (mm)               |              | 1.5 x 4 x 42 (38 x 100 x 1070) |                   | 1.5 x 4 x 42 (38 x 100 x 1070) |                   | 1.5 x 4 x 42 (38 x 100 x 1070) |  |
| <b>R</b> Fork Adjustment (minimum / maximum)             | in (mm)               |              | 15 (381) / 30 (762)            |                   | 15 (381) / 30 (762)            |                   | 15 (381) / 30 (762)            |  |
| <b>S</b> Step Height                                     | in (mm)               |              | 9 (229)                        |                   | 9 (229)                        |                   | 9 (229)                        |  |
| <b>T</b> Battery Roller Height                           | in (mm)               |              | 7 (178)                        |                   | 7 (178)                        |                   | 7 (178)                        |  |
| <b>U</b> Bumper to Centerline of Drive Wheel             | in (mm)               |              | 11.35 (288)                    |                   | 11.35 (288)                    |                   | 11.35 (288)                    |  |
| <b>V</b> Underclearance (centerline of wheelbase)        | in (mm)               |              | 2 (50)                         |                   | 2 (50)                         |                   | 2 (50)                         |  |
| Reach Stroke   | in (mm)               |              | 22.75 (578)                    |                   | 22.75 (578)                    |                   | 22.75 (578)                    |  |
| Maximum Reach  | in (mm)               |              | 28.5 (724)                     |                   | 28.5 (724)                     |                   | 28.5 (724)                     |  |
| <b>W</b> Outside Turning Radius                          | in (mm)               |              | 70.8 (1798)                    |                   | 72.8 (1849)                    |                   | 74.8 (1900)                    |  |
| PERFORMANCE DATA   |                       |              | 9BRU18 / 14.5                  |                   | 9BRU18 / 16.5                  |                   | 9BRU18 / 18.5                  |  |
|  |                       |              | 24V                            | 36V               | 24V                            | 36V               | 36V                            |  |
| Maximum Travel Speed                                     | Full Load             | mph (km/h)   | 6.5 (10.5)                     | 7.5 (12.1)        | 6.5 (10.5)                     | 7.5 (12.1)        | 7.5 (12.1)                     |  |
|  | No Load               | mph (km/h)   | 6.5 (10.5)                     | 7.5 (12.1)        | 6.5 (10.5)                     | 7.5 (12.1)        | 7.5 (12.1)                     |  |
| Lifting Speed  | Full Load             | fpm (mm/sec) | 40 (200)                       | 70 (355)          | 40 (200)                       | 70 (355)          | 70 (355)                       |  |
|  | No Load               | fpm (mm/sec) | 64 (325)                       | 100 (508)         | 64 (325)                       | 100 (508)         | 100 (508)                      |  |
| Lowering Speed   | Full Load             | fpm (mm/sec) | 110 (559)                      | 110 (559)         | 110 (559)                      | 110 (559)         | 110 (559)                      |  |
|  | No Load               | fpm (mm/sec) | 110 (559)                      | 110 (559)         | 110 (559)                      | 110 (559)         | 110 (559)                      |  |
| Out of Free-Lift   |                       | mph (km/h)   | 0 - 3.5 (0 - 5.6)              | 0 - 3.5 (0 - 5.6) | 0 - 3.5 (0 - 5.6)              | 0 - 3.5 (0 - 5.6) | 0 - 3.5 (0 - 5.6)              |  |
| Maximum Reach / Retract                                  | Full Load             | sec          | 4.8                            | 4.8               | 4.8                            | 4.8               | 4.8                            |  |
|  | No Load               | sec          | 4.8                            | 4.8               | 4.8                            | 4.8               | 4.8                            |  |
| POWER SYSTEM   |                       |              | 9BRU18 / 14.5                  |                   | 9BRU18 / 16.5                  |                   | 9BRU18 / 18.5                  |  |
| Battery Type   |                       |              | Lead Acid                      |                   | Lead Acid                      |                   | Lead Acid                      |  |
| Voltage / Capacity (6-hour ratings)                      | Maximum               | V / AH       | 24 / 1080                      | 36 / 1240         | 24 / 1080                      | 36 / 1240         | 36 / 1240                      |  |
|  | Minimum               | lb (kg)      | 1600 (726)                     | 1600 (726)        | 2000 (907)                     | 2000 (907)        | 2300 (1043)                    |  |
| Weight   | Maximum               | lb (kg)      | 2000 (907)                     | 2000 (907)        | 2300 (1043)                    | 2300 (1043)       | 2600 (1179)                    |  |
|  | Drive                 | hp (kw)      | 6.3 (4.7)                      | 7.1 (5.3)         | 6.3 (4.7)                      | 7.1 (5.3)         | 7.1 (5.3)                      |  |
| Electric Motors  | Load Handling         | hp (kw)      | 14.1 (10.5)                    | 17.3 (12.9)       | 14.1 (10.5)                    | 17.3 (12.9)       | 17.3 (12.9)                    |  |
| CONTROL TYPE   |                       |              | 9BRU18 / 14.5                  |                   | 9BRU18 / 16.5                  |                   | 9BRU18 / 18.5                  |  |
| Drive  |                       |              | AC                             | AC                | AC                             | AC                | AC                             |  |
| Load Handling  |                       |              | AC                             | AC                | AC                             | AC                | AC                             |  |
| Power Steering   |                       |              | Transistor                     | Transistor        | Transistor                     | Transistor        | Transistor                     |  |
| TIRES  |                       |              | 9BRU18 / 14.5                  |                   | 9BRU18 / 16.5                  |                   | 9BRU18 / 18.5                  |  |
| Tire Type  |                       |              | Polyurethane                   |                   | Polyurethane                   |                   | Polyurethane                   |  |
| Wheels (x = driven)                                      | Drive / Caster / Load |              | 1x / 1 / 4                     |                   | 1x / 1 / 4                     |                   | 1x / 1 / 4                     |  |
|  | Drive                 | in (mm)      | 13.5 x 6.0 (345 x 152.4)       |                   | 13.5 x 6.0 (345 x 152.4)       |                   | 13.5 x 6.0 (345 x 152.4)       |  |
| Size (diameter x width)                                  | Caster                | in (mm)      | 8 x 4 (203 x 102)              |                   | 8 x 4 (203 x 102)              |                   | 8 x 4 (203 x 102)              |  |
|  | Load                  | in (mm)      | 5 x 3.63 (127 x 92)            |                   | 5 x 3.63 (127 x 92)            |                   | 5 x 3.63 (127 x 92)            |  |
| Suspension   | Caster                |              | Spring Loaded                  |                   | Spring Loaded                  |                   | Spring Loaded                  |  |
| Grade Clearance  | %                     |              | 14                             |                   | 14                             |                   | 14                             |  |
| Brake Type   |                       |              | Electric Disc                  |                   | Electric Disc                  |                   | Electric Disc                  |  |

1 Please refer to the Mast Specifications & Rated Capacities charts.  
 2 Please refer to the Battery Compartment Specification Chart.

3 Add 8.5" (216 mm) for optional extended operator backrest.  
 4 Overhead guard height with FSV 89" / 193" mast is 88.75" (2254 mm).

MODEL NUMBERS / BATTERY COMPARTMENT SIZE

| GENERAL DATA   |                       |              | 9BDRU13 / 14.5                 | 9BDRU13 / 16.5                 |
|--|-----------------------|--------------|--------------------------------|--------------------------------|
| Type / Load Capacity <sup>1</sup> (with 24" load center) | lb (kg)               |              | Double Reach / 2500 (1134)     | Double Reach / 2500 (1134)     |
| Total Weight (without battery)                           | lb (kg)               |              | 6558 (2975)                    | 6608 (2997)                    |
| Operator Position  |                       |              | Stand-Up Rider                 | Stand-Up Rider                 |
| EXTERIOR DIMENSIONS                                      |                       |              | 9BDRU13 / 14.5                 | 9BDRU13 / 16.5                 |
| <b>A</b> Battery Compartment Size <sup>2</sup> (length)  | in (mm)               |              | 14.5 (368)                     | 16.5 (419)                     |
| <b>B</b> Maximum Fork Height <sup>1</sup>                | in (mm)               |              | 264 (6706)                     | 264 (6706)                     |
| <b>C</b> Mast Lowered Height                             | in (mm)               |              | 118 (2997)                     | 118 (2997)                     |
| <b>D</b> Mast Extended Height                            | in (mm)               |              | 312 (7925)                     | 312 (7925)                     |
| <b>E</b> Free-Lift                                       | in (mm)               |              | 79 (2007)                      | 79 (2007)                      |
| <b>F</b> Wheelbase                                       | in (mm)               |              | 59.6 (1514)                    | 61.6 (1565)                    |
| <b>G</b> Head Length (length to fork face)               | in (mm)               |              | 60 (1524)                      | 62 (1575)                      |
| <b>H</b> Truck Length (length to end of base legs)       | in (mm)               |              | 81.3 (2065)                    | 83.3 (2116)                    |
| <b>I</b> Power Unit Length                               | in (mm)               |              | 35.5 (902)                     | 37.5 (952)                     |
| <b>J</b> Power Unit Width                                | in (mm)               |              | 42.5 (1080)                    | 42.5 (1080)                    |
| <b>K</b> Power Unit Height <sup>3</sup>                  | in (mm)               |              | 51.5 (1308)                    | 51.5 (1308)                    |
| <b>L</b> Carriage Width                                  | in (mm)               |              | 32 (813)                       | 32 (813)                       |
| <b>M</b> Load Backrest Height                            | in (mm)               |              | 48 (1220)                      | 48 (1220)                      |
| <b>N</b> Tilt Range (forward / backward)                 | deg                   |              | 3 / 4.5                        | 3 / 4.5                        |
| <b>O</b> Overhead Guard Height <sup>4</sup>              | in (mm)               |              | 90.81 (2307)                   | 90.81 (2307)                   |
| <b>P</b> Base Legs Opening (inside dimensions)           | in (mm)               |              | 33 - 50 (838 - 1270)           | 33 - 50 (838 - 1270)           |
| <b>Q</b> Base Legs Overall Width (outside dimensions)    | in (mm)               |              | 43 - 60 (1092 - 1524)          | 43 - 60 (1092 - 1524)          |
| Base Leg Width   | in (mm)               |              | 5 (127)                        | 5 (127)                        |
| Fork Size (T x W x L)                                    | in (mm)               |              | 1.5 x 4 x 42 (38 x 100 x 1070) | 1.5 x 4 x 42 (38 x 100 x 1070) |
| <b>R</b> Fork Adjustment (minimum / maximum)             | in (mm)               |              | 15 (381) / 30 (762)            | 15 (381) / 30 (762)            |
| <b>S</b> Step Height                                     | in (mm)               |              | 9 (229)                        | 9 (229)                        |
| <b>T</b> Battery Roller Height                           | in (mm)               |              | 7 (178)                        | 7 (178)                        |
| <b>U</b> Bumper to Centerline of Drive Wheel             | in (mm)               |              | 11.35 (288)                    | 11.35 (288)                    |
| <b>V</b> Underclearance (centerline of wheelbase)        | in (mm)               |              | 2 (50)                         | 2 (50)                         |
| Reach Stroke   | in (mm)               |              | 42.75 (1086)                   | 42.75 (1086)                   |
| Maximum Reach  | in (mm)               |              | 53.25 (1353)                   | 53.25 (1353)                   |
| <b>W</b> Outside Turning Radius                          | in (mm)               |              | 73.6 (1869)                    | 75.6 (1920)                    |
| PERFORMANCE DATA   |                       |              | 9BDRU13 / 14.5                 | 9BDRU13 / 16.5                 |
| Maximum Travel Speed                                     | Full Load             | mph (km/h)   | 6.5 (10.5)                     | 6.5 (10.5)                     |
|  | No Load               | mph (km/h)   | 6.5 (10.5)                     | 6.5 (10.5)                     |
| Lifting Speed  | Full Load             | fpm (mm/sec) | 40 (200)                       | 40 (200)                       |
|  | No Load               | fpm (mm/sec) | 60 (305)                       | 60 (305)                       |
| Lowering Speed   | Full Load             | fpm (mm/sec) | 110 (559)                      | 110 (559)                      |
|  | No Load               | fpm (mm/sec) | 110 (559)                      | 110 (559)                      |
| Out of Free-Lift   |                       | mph (km/h)   | 0 - 3.5 (0 - 5.6)              | 0 - 3.5 (0 - 5.6)              |
| Maximum Reach / Retract                                  | Full Load             | sec          | 5.0                            | 5.0                            |
|  | No Load               | sec          | 5.0                            | 5.0                            |
| POWER SYSTEM   |                       |              | 9BDRU13 / 14.5                 | 9BDRU13 / 16.5                 |
| Battery Type   |                       |              | Lead Acid                      | Lead Acid                      |
| Voltage / Capacity (6-hour ratings)                      | Maximum               | V / AH       | 24 / 1080                      | 24 / 1080                      |
|  | Minimum               | lb (kg)      | 1600 (726)                     | 2000 (907)                     |
| Weight   | Maximum               | lb (kg)      | 2000 (907)                     | 2300 (1043)                    |
|  | Drive                 | hp (kw)      | 6.3 (4.7)                      | 6.3 (4.7)                      |
| Electric Motors  | Load Handling         | hp (kw)      | 14.1 (11)                      | 14.1 (11)                      |
|  |                       |              |                                |                                |
| CONTROL TYPE   |                       |              | 9BDRU13 / 14.5                 | 9BDRU13 / 16.5                 |
| Drive  |                       |              | AC                             | AC                             |
| Load Handling  |                       |              | AC                             | AC                             |
| Power Steering   |                       |              | Transistor                     | Transistor                     |
| TIRES  |                       |              | 9BDRU13 / 14.5                 | 9BDRU13 / 16.5                 |
| Tire Type  |                       |              | Polyurethane                   | Polyurethane                   |
| Wheels (x = driven)                                      | Drive / Caster / Load |              | 1x / 1 / 4                     | 1x / 1 / 4                     |
|  | Drive                 | in (mm)      | 13.5 x 6.0 (345 x 152.4)       | 13.5 x 6.0 (345 x 152.4)       |
| Size (diameter x width)                                  | Caster                | in (mm)      | 8 x 4 (203 x 102)              | 8 x 4 (203 x 102)              |
|  | Load                  | in (mm)      | 5 x 3.63 (127 x 92)            | 5 x 3.63 (127 x 92)            |
| Suspension   | Caster                |              | Spring Loaded                  | Spring Loaded                  |
| Grade Clearance  |                       | %            | 14                             | 14                             |
| Brake Type   |                       |              | Electric Disc                  | Electric Disc                  |

1 Please refer to the Mast Specifications & Rated Capacities charts.

2 Please refer to the Battery Compartment Specification Chart.

3 Add 8.5" (216 mm) for optional extended operator backrest.

4 Overhead guard height with FSV 89" / 193" mast is 88.75" (2254 mm).

# TRUCK SPECIFICATIONS

## MODEL NUMBERS / BATTERY COMPARTMENT SIZE

| GENERAL DATA   |                       |              | 9BRU23 / 16.5                   | 9BRU23 / 18.5                   | 9BRU23 / 21.5                   |
|--|-----------------------|--------------|---------------------------------|---------------------------------|---------------------------------|
| Type / Load Capacity <sup>1</sup> (with 24" load center) | lb (kg)               |              | Single Reach / 4500 (2040)      | Single Reach / 4500 (2040)      | Single Reach / 4500 (2040)      |
| Total Weight (without battery)                           | lb (kg)               |              | 6364 (2887)                     | 6414 (2909)                     | 6514 (2955)                     |
| Operator Position  |                       |              | Stand-Up Rider                  | Stand-Up Rider                  | Stand-Up Rider                  |
| EXTERIOR DIMENSIONS                                      |                       |              | 9BRU23 / 16.5                   | 9BRU23 / 18.5                   | 9BRU23 / 21.5                   |
| <b>A</b> Battery Compartment Size <sup>2</sup> (length)  | in (mm)               |              | 16.5 (419)                      | 18.5 (470)                      | 21.5 (546)                      |
| <b>B</b> Maximum Fork Height <sup>1</sup>                | in (mm)               |              | 301 (7645)                      | 301 (7645)                      | 301 (7645)                      |
| <b>C</b> Mast Lowered Height                             | in (mm)               |              | 131 (3327)                      | 131 (3327)                      | 131 (3327)                      |
| <b>D</b> Mast Extended Height                            | in (mm)               |              | 349 (8865)                      | 349 (8865)                      | 349 (8865)                      |
| <b>E</b> Free-Lift                                       | in (mm)               |              | 88 (2235)                       | 88 (2235)                       | 88 (2235)                       |
| <b>F</b> Wheelbase                                       | in (mm)               |              | 59.1 (1501)                     | 61.1 (1552)                     | 64.1 (1628)                     |
| <b>G</b> Head Length (length to fork face)               | in (mm)               |              | 57.3 (1430)                     | 59.3 (1506)                     | 62.3 (1582)                     |
| <b>H</b> Truck Length (length to end of base legs)       | in (mm)               |              | 78.2 (1986)                     | 80.2 (2037)                     | 83.2 (2113)                     |
| <b>I</b> Power Unit Length                               | in (mm)               |              | 37.5 (953)                      | 39.5 (1003)                     | 42.5 (1080)                     |
| <b>J</b> Power Unit Width                                | in (mm)               |              | 42.5 (1080)                     | 42.5 (1080)                     | 42.5 (1080)                     |
| <b>K</b> Power Unit Height <sup>3</sup>                  | in (mm)               |              | 51.5 (1308)                     | 51.5 (1308)                     | 51.5 (1308)                     |
| <b>L</b> Carriage Width                                  | in (mm)               |              | 32 (813)                        | 32 (813)                        | 32 (813)                        |
| <b>M</b> Load Backrest Height                            | in (mm)               |              | 48 (1220)                       | 48 (1220)                       | 48 (1220)                       |
| <b>N</b> Tilt Range (forward / backward)                 | deg                   |              | 3 / 4.5                         | 3 / 4.5                         | 3 / 4.5                         |
| <b>O</b> Overhead Guard Height <sup>4</sup>              | in (mm)               |              | 90.81 (2307)                    | 90.81 (2307)                    | 90.81 (2307)                    |
| <b>P</b> Base Legs Opening (inside dimensions)           | in (mm)               |              | 33 - 50 (838 - 1270)            | 33 - 50 (838 - 1270)            | 33 - 50 (838 - 1270)            |
| <b>Q</b> Base Legs Overall Width (outside dimensions)    | in (mm)               |              | 44 - 61 (1118 - 1550)           | 44 - 61 (1118 - 1550)           | 44 - 61 (1118 - 1550)           |
| Base Leg Width   | in (mm)               |              | 5.5 (140)                       | 5.5 (140)                       | 5.5 (140)                       |
| Fork Size (T x W x L)                                    | in (mm)               |              | 1.75 x 4 x 42 (45 x 100 x 1070) | 1.75 x 4 x 42 (45 x 100 x 1070) | 1.75 x 4 x 42 (45 x 100 x 1070) |
| <b>R</b> Fork Adjustment (minimum / maximum)             | in (mm)               |              | 15 (381) / 30 (762)             | 15 (381) / 30 (762)             | 15 (381) / 30 (762)             |
| <b>S</b> Step Height                                     | in (mm)               |              | 9 (229)                         | 9 (229)                         | 9 (229)                         |
| <b>T</b> Battery Roller Height                           | in (mm)               |              | 7 (175)                         | 7 (175)                         | 7 (175)                         |
| <b>U</b> Bumper to Centerline of Drive Wheel             | in (mm)               |              | 11.35 (288)                     | 11.35 (288)                     | 11.35 (288)                     |
| <b>V</b> Underclearance (centerline of wheelbase)        | in (mm)               |              | 2 (50)                          | 2 (50)                          | 2 (50)                          |
| Reach Stroke   | in (mm)               |              | 22.75 (578)                     | 22.75 (578)                     | 22.75 (578)                     |
| Maximum Reach  | in (mm)               |              | 28.5 (724)                      | 28.5 (724)                      | 28.5 (724)                      |
| <b>W</b> Outside Turning Radius                          | in (mm)               |              | 74.2 (1885)                     | 76.2 (1935)                     | 79.2 (2012)                     |
| PERFORMANCE DATA   |                       |              | 9BRU23 / 16.5                   | 9BRU23 / 18.5                   | 9BRU23 / 21.5                   |
| Maximum Travel Speed                                     | Full Load             | mph (km/h)   | 7.5 (12.1)                      | 7.5 (12.1)                      | 7.5 (12.1)                      |
|  | No Load               | mph (km/h)   | 7.5 (12.1)                      | 7.5 (12.1)                      | 7.5 (12.1)                      |
| Lifting Speed  | Full Load             | fpm (mm/sec) | 65 (330)                        | 65 (330)                        | 65 (330)                        |
|  | No Load               | fpm (mm/sec) | 115 (584)                       | 115 (584)                       | 115 (584)                       |
| Lowering Speed   | Full Load             | fpm (mm/sec) | 110 (559)                       | 110 (559)                       | 110 (559)                       |
|  | No Load               | fpm (mm/sec) | 110 (559)                       | 110 (559)                       | 110 (559)                       |
| Out of Free-Lift   |                       | mph (km/h)   | 0 - 3.5 (0 - 5.6)               | 0 - 3.5 (0 - 5.6)               | 0 - 3.5 (0 - 5.6)               |
| Maximum Reach / Retract                                  | Full Load             | sec          | 4.8                             | 4.8                             | 4.8                             |
|  | No Load               | sec          | 4.8                             | 4.8                             | 4.8                             |
| POWER SYSTEM   |                       |              | 9BRU23 / 16.5                   | 9BRU23 / 18.5                   | 9BRU23 / 21.5                   |
| Battery Type   |                       |              | Lead Acid                       | Lead Acid                       | Lead Acid                       |
| Voltage / Capacity (6-hour ratings)                      | Maximum               | V / AH       | 36 / 1240                       | 36 / 1240                       | 36 / 1240                       |
| Weight   | Minimum               | lb (kg)      | 2000 (907)                      | 2300 (1043)                     | 2600 (1179)                     |
|  | Maximum               | lb (kg)      | 2300 (1043)                     | 2600 (1179)                     | 2900 (1315)                     |
| Electric Motors  | Drive                 | hp (kw)      | 7.1 (5.3)                       | 7.1 (5.3)                       | 7.1 (5.3)                       |
|  | Load Handling         | hp (kw)      | 17.3 (12.9)                     | 17.3 (12.9)                     | 17.3 (12.9)                     |
| CONTROL TYPE   |                       |              | 9BRU23 / 16.5                   | 9BRU23 / 18.5                   | 9BRU23 / 21.5                   |
| Drive  |                       |              | AC                              | AC                              | AC                              |
| Load Handling  |                       |              | AC                              | AC                              | AC                              |
| Power Steering   |                       |              | Transistor                      | Transistor                      | Transistor                      |
| TIRES  |                       |              | 9BRU23 / 16.5                   | 9BRU23 / 18.5                   | 9BRU23 / 21.5                   |
| Tire Type  |                       |              | Polyurethane                    | Polyurethane                    | Polyurethane                    |
| Wheels (x = driven)                                      | Drive / Caster / Load |              | 1x / 1 / 4                      | 1x / 1 / 4                      | 1x / 1 / 4                      |
|  | Drive                 | in (mm)      | 13.5 x 6.0 (345 x 152.4)        | 13.5 x 6.0 (345 x 152.4)        | 13.5 x 6.0 (345 x 152.4)        |
| Size (diameter x width)                                  | Caster                | in (mm)      | 8 x 4 (203 x 102)               | 8 x 4 (203 x 102)               | 8 x 4 (203 x 102)               |
|  | Load                  | in (mm)      | 5 x 3.63 (127 x 92)             | 5 x 3.63 (127 x 92)             | 5 x 3.63 (127 x 92)             |
| Suspension   | Caster                |              | Spring Loaded                   | Spring Loaded                   | Spring Loaded                   |
| Grade Clearance  |                       | %            | 14                              | 14                              | 14                              |
| Brake Type   |                       |              | Electric Disc                   | Electric Disc                   | Electric Disc                   |

1 Please refer to the Mast Specifications & Rated Capacities charts.  
 2 Please refer to the Battery Compartment Specification Chart.  
 3 Add 8.5" (216 mm) for optional extended operator backrest.  
 4 Overhead guard height with FSV 89" / 193" mast is 88.75" (2254 mm).

MODEL NUMBERS / BATTERY COMPARTMENT SIZE

| GENERAL DATA   |                       |              | 98DRU15 / 16.5                  | 98DRU15 / 18.5                  | 98DRU15 / 21.5                  |
|--|-----------------------|--------------|---------------------------------|---------------------------------|---------------------------------|
| Type / Load Capacity <sup>1</sup> (with 24" load center) | lb (kg)               |              | Double Reach / 3000 (1360)      | Double Reach / 3000 (1360)      | Double Reach / 3000 (1360)      |
| Total Weight (without battery)                           | lb (kg)               |              | 6608 (2997)                     | 6658 (3020)                     | 6758 (3065)                     |
| Operator Position  |                       |              | Stand-Up Rider                  | Stand-Up Rider                  | Stand-Up Rider                  |
| EXTERIOR DIMENSIONS                                      |                       |              | 98DRU15 / 16.5                  | 98DRU15 / 18.5                  | 98DRU15 / 21.5                  |
| <b>A</b> Battery Compartment Size <sup>2</sup> (length)  | in (mm)               |              | 16.5 (419)                      | 18.5 (470)                      | 21.5 (546)                      |
| <b>B</b> Maximum Fork Height <sup>1</sup>                | in (mm)               |              | 302 (7671)                      | 302 (7671)                      | 302 (7671)                      |
| <b>C</b> Mast Lowered Height                             | in (mm)               |              | 135 (3429)                      | 135 (3429)                      | 135 (3429)                      |
| <b>D</b> Mast Extended Height                            | in (mm)               |              | 350 (7671)                      | 350 (7671)                      | 350 (7671)                      |
| <b>E</b> Free-Lift                                       | in (mm)               |              | 96 (2438)                       | 96 (2438)                       | 96 (2438)                       |
| <b>F</b> Wheelbase                                       | in (mm)               |              | 61.6 (1565)                     | 63.6 (1615)                     | 66.6 (1692)                     |
| <b>G</b> Head Length (length to fork face)               | in (mm)               |              | 62 (1575)                       | 64 (1626)                       | 67 (1702)                       |
| <b>H</b> Truck Length (length to end of base legs)       | in (mm)               |              | 83.3 (2116)                     | 85.3 (2167)                     | 88.3 (2243)                     |
| <b>I</b> Power Unit Length                               | in (mm)               |              | 37.5 (953)                      | 39.5 (1003)                     | 42.5 (1080)                     |
| <b>J</b> Power Unit Width                                | in (mm)               |              | 42.5 (1080)                     | 42.5 (1080)                     | 42.5 (1080)                     |
| <b>K</b> Power Unit Height <sup>3</sup>                  | in (mm)               |              | 51.5 (1308)                     | 51.5 (1308)                     | 51.5 (1308)                     |
| <b>L</b> Carriage Width                                  | in (mm)               |              | 32 (813)                        | 32 (813)                        | 32 (813)                        |
| <b>M</b> Load Backrest Height                            | in (mm)               |              | 48 (1219)                       | 48 (1219)                       | 48 (1219)                       |
| <b>N</b> Tilt Range (forward / backward)                 | deg                   |              | 3 / 4.5                         | 3 / 4.5                         | 3 / 4.5                         |
| <b>O</b> Overhead Guard Height <sup>4</sup>              | in (mm)               |              | 90.81 (2307)                    | 90.81 (2307)                    | 90.81 (2307)                    |
| <b>P</b> Base Legs Opening (inside dimensions)           | in (mm)               |              | 33 – 50 (838 – 1270)            | 33 – 50 (838 – 1270)            | 33 – 50 (838 – 1270)            |
| <b>Q</b> Base Legs Overall Width (outside dimensions)    | in (mm)               |              | 43 – 60 (1092 – 1524)           | 43 – 60 (1092 – 1524)           | 43 – 60 (1092 – 1524)           |
| Base Leg Width   | in (mm)               |              | 5 (127)                         | 5 (127)                         | 5 (127)                         |
| Fork Size (T x W x L)                                    | in (mm)               |              | 1.75 x 4 x 42 (45 x 100 x 1070) | 1.75 x 4 x 42 (45 x 100 x 1070) | 1.75 x 4 x 42 (45 x 100 x 1070) |
| <b>R</b> Fork Adjustment (minimum / maximum)             | in (mm)               |              | 15 (381) / 30 (762)             | 15 (381) / 30 (762)             | 15 (381) / 30 (762)             |
| <b>S</b> Step Height                                     | in (mm)               |              | 9 (229)                         | 9 (229)                         | 9 (229)                         |
| <b>T</b> Battery Roller Height                           | in (mm)               |              | 7 (175)                         | 7 (175)                         | 7 (175)                         |
| <b>U</b> Bumper to Centerline of Drive Wheel             | in (mm)               |              | 11.35 (288)                     | 11.35 (288)                     | 11.35 (288)                     |
| <b>V</b> Underclearance (centerline of wheelbase)        | in (mm)               |              | 2 (50)                          | 2 (50)                          | 2 (50)                          |
| Reach Stroke   | in (mm)               |              | 42.75 (1086)                    | 42.75 (1086)                    | 42.75 (1086)                    |
| Maximum Reach  | in (mm)               |              | 53.25 (1352)                    | 53.25 (1352)                    | 53.25 (1352)                    |
| <b>W</b> Outside Turning Radius                          | in (mm)               |              | 75.6 (1920)                     | 77.6 (1971)                     | 80.6 (2047)                     |
| PERFORMANCE DATA   |                       |              | 98DRU15 / 16.5                  | 98DRU15 / 18.5                  | 98DRU15 / 21.5                  |
| Maximum Travel Speed                                     | Full Load             | mph (km/h)   | 7.5 (12.1)                      | 7.5 (12.1)                      | 7.5 (12.1)                      |
|  | No Load               | mph (km/h)   | 7.5 (12.1)                      | 7.5 (12.1)                      | 7.5 (12.1)                      |
| Lifting Speed  | Full Load             | fpm (mm/sec) | 75 (381)                        | 75 (381)                        | 75 (381)                        |
|  | No Load               | fpm (mm/sec) | 110 (559)                       | 110 (559)                       | 110 (559)                       |
| Lowering Speed   | Full Load             | fpm (mm/sec) | 110 (559)                       | 110 (559)                       | 110 (559)                       |
|  | No Load               | fpm (mm/sec) | 110 (559)                       | 110 (559)                       | 110 (559)                       |
| Out of Free-Lift   |                       | mph (km/h)   | 0 – 3.5 (0 – 5.6)               | 0 – 3.5 (0 – 5.6)               | 0 – 3.5 (0 – 5.6)               |
| Maximum Reach / Retract                                  | Full Load             | sec          | 5.0                             | 5.0                             | 5.0                             |
|  | No Load               | sec          | 5.0                             | 5.0                             | 5.0                             |
| POWER SYSTEM   |                       |              | 98DRU15 / 16.5                  | 98DRU15 / 18.5                  | 98DRU15 / 21.5                  |
| Battery Type   |                       |              | Lead Acid                       | Lead Acid                       | Lead Acid                       |
| Voltage / Capacity (6-hour ratings)                      | Maximum               | V / AH       | 36 / 1240                       | 36 / 1240                       | 36 / 1240                       |
|  | Weight                | lb (kg)      | 2000 (900)                      | 2300 (1040)                     | 2600 (1179)                     |
| Electric Motors  | Maximum               | lb (kg)      | 2300 (1040)                     | 2600 (1179)                     | 2900 (1310)                     |
|  | Drive                 | hp (kw)      | 7.1 (5.3)                       | 7.1 (5.3)                       | 7.1 (5.3)                       |
| Load Handling  | hp (kw)               |              | 17.3 (12.9)                     | 17.3 (12.9)                     | 17.3 (12.9)                     |
| CONTROL TYPE   |                       |              | 98DRU15 / 16.5                  | 98DRU15 / 18.5                  | 98DRU15 / 21.5                  |
| Drive  |                       |              | AC                              | AC                              | AC                              |
| Load Handling  |                       |              | AC                              | AC                              | AC                              |
| Power Steering   |                       |              | Transistor                      | Transistor                      | Transistor                      |
| TIRES  |                       |              | 98DRU15 / 16.5                  | 98DRU15 / 18.5                  | 98DRU15 / 21.5                  |
| Tire Type  |                       |              | Polyurethane                    | Polyurethane                    | Polyurethane                    |
| Wheels (x = driven)                                      | Drive / Caster / Load |              | 1x / 1 / 4                      | 1x / 1 / 4                      | 1x / 1 / 4                      |
|  | Drive                 | in (mm)      | 13.5 x 6.0 (345 x 152.4)        | 13.5 x 6.0 (345 x 152.4)        | 13.5 x 6.0 (345 x 152.4)        |
| Size (diameter x width)                                  | Caster                | in (mm)      | 8 x 4 (203 x 102)               | 8 x 4 (203 x 102)               | 8 x 4 (203 x 102)               |
|  | Load                  | in (mm)      | 5 x 3.63 (127 x 92)             | 5 x 3.63 (127 x 92)             | 5 x 3.63 (127 x 92)             |
| Suspension   | Caster                |              | Spring Loaded                   | Spring Loaded                   | Spring Loaded                   |
| Grade Clearance  | %                     |              | 14                              | 14                              | 14                              |
| Brake Type   |                       |              | Electric Disc                   | Electric Disc                   | Electric Disc                   |

1 Please refer to the Mast Specifications & Rated Capacities charts.  
 2 Please refer to the Battery Compartment Specification Chart.  
 3 Add 8.5" (216 mm) for optional extended operator backrest.  
 4 Overhead guard height with FSV 89" / 193" mast is 88.75" (2254 mm).

TRUCK DIMENSIONS

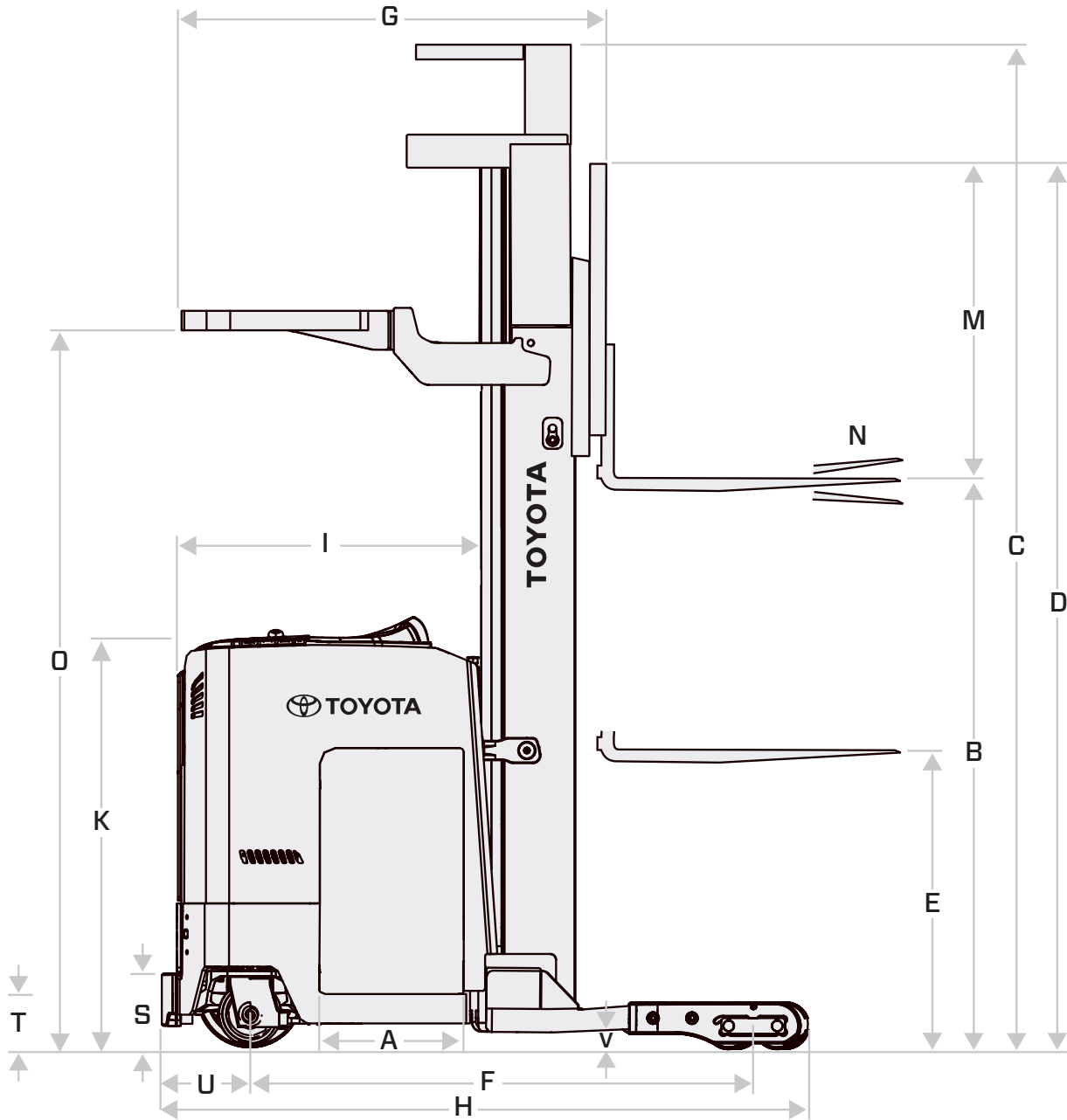



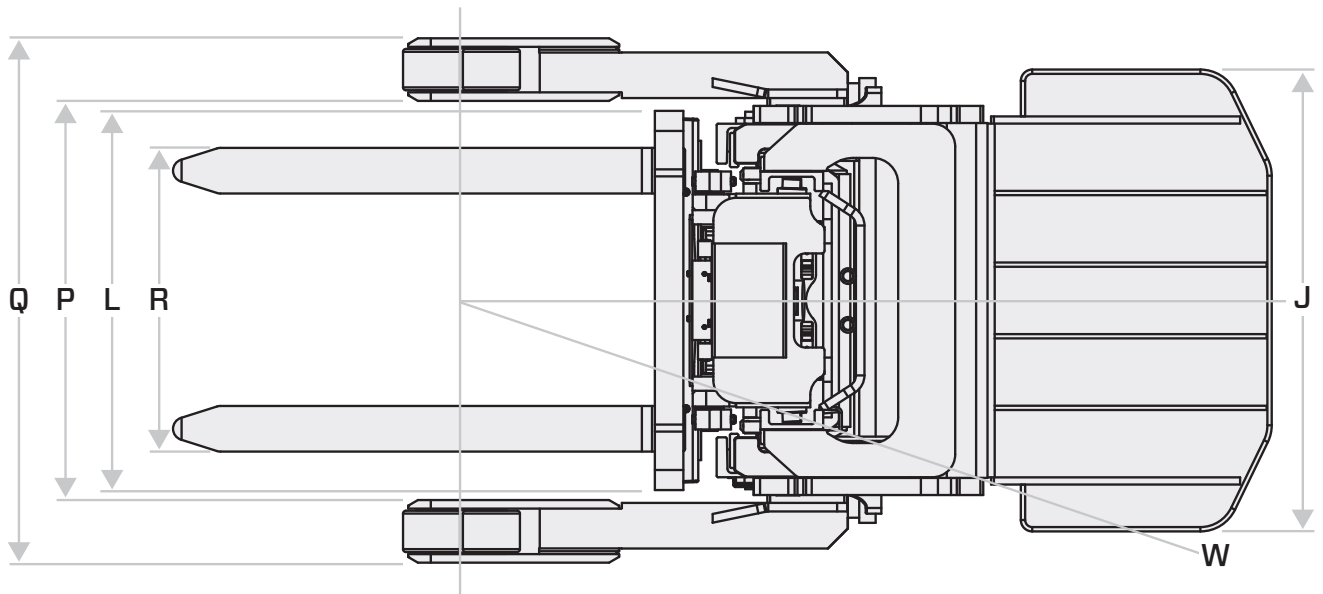

## MAST SPECIFICATIONS

| MAST TYPE                          | MAXIMUM FORK HEIGHT<br>(TOP OF FORKS) | OVERALL HEIGHT |                             | FREE-LIFT                   | TILT RANGE <sup>3</sup> |     |
|------------------------------------|---------------------------------------|----------------|-----------------------------|-----------------------------|-------------------------|-----|
|                                    |                                       | LOWERED        | WITH STANDARD LOAD BACKREST | WITH STANDARD LOAD BACKREST | FWD                     | BWD |
|                                    |                                       | in (mm)        | in (mm)                     | in (mm)                     | deg                     | deg |
| <b>9BRU18</b>                      |                                       |                |                             |                             |                         |     |
| Full Free-Lift<br>3-Stage<br>(FSV) | 193 (4902) <sup>1</sup>               | 89 (2261)      | 241 (6121)                  | 46 (1168)                   | 3                       | 4.5 |
|                                    | 211 (5359)                            | 95 (2413)      | 259 (6579)                  | 52 (1321)                   | 3                       | 4.5 |
|                                    | 217 (5512)                            | 99 (2515)      | 265 (6731)                  | 56 (1422)                   | 3                       | 4.5 |
|                                    | 241 (6121)                            | 107 (2718)     | 289 (7341)                  | 64 (1626)                   | 3                       | 4.5 |
|                                    | 250 (6350)                            | 110 (2794)     | 298 (7569)                  | 67 (1701)                   | 3                       | 4.5 |
|                                    | 271 (6883)                            | 119 (3023)     | 319 (8103)                  | 76 (1930)                   | 3                       | 4.5 |
|                                    | 280 (7112)                            | 122 (3099)     | 328 (8331)                  | 79 (2007)                   | 3                       | 4.5 |
| 301 (7645)                         | 131 (3327)                            | 349 (8865)     | 88 (2235)                   | 3                           | 4.5                     |     |
| <b>9BDRU13</b>                     |                                       |                |                             |                             |                         |     |
| Full Free-Lift<br>3-Stage<br>(FSV) | 189 (4801) <sup>1</sup>               | 89 (2261)      | 237 (6020)                  | 47 (1194)                   | 3                       | 4.5 |
|                                    | 207 (5258)                            | 95 (2413)      | 255 (6477)                  | 57 (1448)                   | 3                       | 4.5 |
|                                    | 216 (5486)                            | 100 (2540)     | 264 (6706)                  | 62 (1575)                   | 3                       | 4.5 |
|                                    | 237 (6020)                            | 107 (2718)     | 285 (7239)                  | 68 (1727)                   | 3                       | 4.5 |
|                                    | 252 (6401)                            | 114 (2896)     | 300 (7620)                  | 75 (1905)                   | 3                       | 4.5 |
|                                    | 264 (6706)                            | 118 (2997)     | 312 (7925)                  | 79 (2007)                   | 3                       | 4.5 |
| <b>9BRU23</b>                      |                                       |                |                             |                             |                         |     |
| Full Free-Lift<br>3-Stage<br>(FSV) | 193 (4902) <sup>2</sup>               | 89 (2260)      | 241 (6121)                  | 46 (1168)                   | 3                       | 4.5 |
|                                    | 211 (5359)                            | 95 (2413)      | 259 (6579)                  | 52 (1321)                   | 3                       | 4.5 |
|                                    | 226 (5740)                            | 102 (2591)     | 274 (6960)                  | 59 (1499)                   | 3                       | 4.5 |
|                                    | 241 (6121)                            | 107 (2718)     | 289 (7341)                  | 64 (1626)                   | 3                       | 4.5 |
|                                    | 250 (6350)                            | 110 (2794)     | 298 (7569)                  | 67 (1702)                   | 3                       | 4.5 |
|                                    | 268 (6807)                            | 118 (2997)     | 316 (8026)                  | 75 (1905)                   | 3                       | 4.5 |
|                                    | 280 (7112)                            | 122 (3099)     | 328 (8331)                  | 79 (2007)                   | 3                       | 4.5 |
|                                    | 301 (7645)                            | 131 (3327)     | 349 (8865)                  | 88 (2235)                   | 3                       | 4.5 |
| <b>9BDRU15</b>                     |                                       |                |                             |                             |                         |     |
| Full Free-Lift<br>3-Stage<br>(FSV) | 189 (4801) <sup>1</sup>               | 89 (2261)      | 237 (6020)                  | 47 (1194)                   | 3                       | 4.5 |
|                                    | 207 (5258)                            | 95 (2413)      | 255 (6477)                  | 57 (1448)                   | 3                       | 4.5 |
|                                    | 216 (5486)                            | 100 (2540)     | 264 (6706)                  | 62 (1575)                   | 3                       | 4.5 |
|                                    | 237 (6020)                            | 107 (2718)     | 285 (7239)                  | 68 (1727)                   | 3                       | 4.5 |
|                                    | 252 (6401)                            | 114 (2896)     | 300 (7620)                  | 75 (1905)                   | 3                       | 4.5 |
|                                    | 264 (6706)                            | 118 (2997)     | 312 (7925)                  | 79 (2007)                   | 3                       | 4.5 |
|                                    | 276 (7010)                            | 122 (3099)     | 324 (8230)                  | 83 (2108)                   | 3                       | 4.5 |
|                                    | 288 (7315)                            | 128 (3251)     | 336 (8534)                  | 89 (2261)                   | 3                       | 4.5 |
|                                    | 302 (7671)                            | 135 (3429)     | 350 (8890)                  | 96 (2438)                   | 3                       | 4.5 |

1 Overhead guard height with FSV 89"; 192" mast is 88.75" (2254 mm).

2 Overhead guard height with FSV 89"; 189" mast is 88.75" (2254 mm).

3 Tilting load backrest.

Note: Height of standard load backrest is 48" (1220 mm).

# aisle width requirements for right-angle stacking

## 9BRU18

|             |           | Load Width |              |              |              |              |              |
|-------------|-----------|------------|--------------|--------------|--------------|--------------|--------------|
|             |           | in (mm)    | 40 (1016)    | 44 (1117)    | 48 (1219)    | 54 (1372)    | 60 (1524)    |
| Load Length | 30 (762)  | in (mm)    | 82.5 (2096)  | 82.5 (2096)  | 82.5 (2096)  | 82.5 (2096)  | 82.5 (2096)  |
|             | 36 (914)  | in (mm)    | 82.5 (2096)  | 82.5 (2096)  | 82.5 (2096)  | 82.5 (2096)  | 82.5 (2096)  |
|             | 40 (1016) | in (mm)    | 87 (2210)    | 86.5 (2197)  | 86 (2184)    | 85.2 (2164)  | 84.4 (2144)  |
|             | 44 (1118) | in (mm)    | 92 (2337)    | 91.5 (2324)  | 91 (2311)    | 90.3 (2294)  | 89.6 (2276)  |
|             | 48 (1219) | in (mm)    | 96.7 (2456)  | 96.3 (2446)  | 95.8 (2433)  | 95.2 (2418)  | 94.6 (2403)  |
|             | 54 (1372) | in (mm)    | 103.5 (2629) | 103.1 (2619) | 102.8 (2611) | 102.2 (2596) | 101.7 (2583) |
|             | 60 (1524) | in (mm)    | 110.1 (2797) | 109.8 (2789) | 109.4 (2779) | 109 (2769)   | 108.5 (2756) |

Minimum aisle width = 14.5" (368 mm) battery compartment.  
4" (100 mm) clearance each side of load.

Add 2" (51 mm) for 16.5" (410 mm) battery compartment.  
Add 4" (102 mm) for 18.5" (460 mm) battery compartment.  
Add a minimum of 6" (150 mm) to 12" (305 mm) for easy maneuvering.  
For base leg inner dimension greater than 41," add 2" to aisle width requirements.

## 9BDRU13

|             |           | Load Width |              |              |              |             |              |
|-------------|-----------|------------|--------------|--------------|--------------|-------------|--------------|
|             |           | in (mm)    | 40 (1016)    | 44 (1117)    | 48 (1219)    | 54 (1372)   | 60 (1524)    |
| Load Length | 40 (1016) | in (mm)    | 94 (2388)    | 93.6 (2377)  | 93.1 (2365)  | 92.4 (2347) | 91.7 (2329)  |
|             | 44 (1118) | in (mm)    | 98.7 (2507)  | 98.3 (2497)  | 97.9 (2487)  | 97.3 (2471) | 96.6 (2454)  |
|             | 48 (1219) | in (mm)    | 103.3 (2624) | 102.9 (2614) | 102.5 (2604) | 102 (2591)  | 101.4 (2576) |

Minimum aisle width = 16.5" (419 mm) battery compartment.  
4" (100 mm) clearance each side of load.

**Note:** Aisle width values shown are based on a 42" (1067 mm) base leg opening (inside dimension).  
Subtract 2" (51 mm) for 14.5" (359 mm) battery compartment.  
Add a minimum of 6" (150 mm) to 12" (305 mm) for easy maneuvering.

## 9BRU23

|             |           | Load Width |              |              |              |              |              |
|-------------|-----------|------------|--------------|--------------|--------------|--------------|--------------|
|             |           | in (mm)    | 40 (1016)    | 44 (1117)    | 48 (1219)    | 54 (1372)    | 60 (1524)    |
| Load Length | 30 (762)  | in (mm)    | 85.3 (2167)  | 85.3 (2167)  | 85.3 (2167)  | 85.3 (2167)  | 85.3 (2167)  |
|             | 36 (914)  | in (mm)    | 85.3 (2167)  | 85.3 (2167)  | 85.3 (2167)  | 85.3 (2167)  | 85.3 (2167)  |
|             | 40 (1016) | in (mm)    | 90 (2286)    | 89.5 (2273)  | 88.9 (2258)  | 88.7 (2253)  | 87.3 (2217)  |
|             | 44 (1118) | in (mm)    | 95 (2413)    | 94.5 (2400)  | 94 (2388)    | 93.3 (2370)  | 92.6 (2352)  |
|             | 48 (1219) | in (mm)    | 99.7 (2532)  | 99.3 (2522)  | 98.9 (2512)  | 98.3 (2497)  | 97.6 (2479)  |
|             | 54 (1372) | in (mm)    | 106.6 (2708) | 106.2 (2697) | 105.9 (2690) | 105.3 (2675) | 104.8 (2662) |
|             | 60 (1524) | in (mm)    | 113.2 (2875) | 112.9 (2868) | 112.6 (2860) | 112.1 (2847) | 111.6 (2835) |

Minimum aisle width = 16.5" (419 mm) battery compartment.  
4" (100 mm) clearance each side of load.

Add 2" (50 mm) for 18.5" battery compartment.  
Add 5" (127 mm) for 21.5" battery compartment.  
Add a minimum of 6" (150 mm) to 12" (305 mm) for easy maneuvering.  
For base leg inner dimension greater than 41," add 2" to aisle width requirements.

## 9BDRU15

|             |           | Load Width |              |              |              |              |              |
|-------------|-----------|------------|--------------|--------------|--------------|--------------|--------------|
|             |           | in (mm)    | 40 (1016)    | 44 (1117)    | 48 (1219)    | 54 (1372)    | 60 (1524)    |
| Load Length | 40 (1016) | in (mm)    | 96 (2438)    | 95.5 (2426)  | 95 (2413)    | 94.4 (2398)  | 93.7 (2380)  |
|             | 44 (1118) | in (mm)    | 100.7 (2558) | 100.3 (2548) | 99.8 (2535)  | 99.2 (2520)  | 98.6 (2504)  |
|             | 48 (1219) | in (mm)    | 105.2 (2672) | 104.9 (2664) | 104.5 (2654) | 103.9 (2639) | 103.4 (2626) |

Minimum aisle width = 16.5" (419 mm) battery compartment.  
4" (100 mm) clearance each side of load.

Add 2" (50 mm) for 18.5" battery compartment.  
Add 5" (127 mm) for 21.5" battery compartment.  
Add a minimum of 6" (150 mm) to 12" (305 mm) for easy maneuvering.  
**Note:** Aisle width values shown are based on a 42" (1067 mm) base leg opening (inside dimension).

Some product features described herein are optional. Please consult your dealer for specifications.  
Details of specifications and equipment are based on information available at time of printing and may change without notice.



**INDUSTRIAL EQUIPMENT**

**REACH NEW HEIGHTS**

007229BRUSS

©2016 Toyota Material Handling, U.S.A., Inc.