

953C

Track Loader



Engine

| | | |
|--------------------|------------------------------|--------|
| Engine Model | Cat [®] 3126B ATAAC | |
| Net Flywheel Power | 95 kW | 128 hp |

Buckets

| | | |
|-------------------------------|---------------------|----------------------|
| Capacity – General Purpose | 1.85 m ³ | 2.42 yd ³ |
| Capacity – Multi-Purpose | 1.6 m ³ | 2.09 yd ³ |

Weights

| | | |
|------------------|-----------|-----------|
| Operating Weight | 15 145 kg | 33,389 lb |
|------------------|-----------|-----------|

953C Track Loader

Leading edge design, state-of-the art technology, and unmatched versatility in one machine allows maximum productivity.

Engine

The 3126B ATAAC diesel engine features a Hydraulic Electronic Unit Injection (HEUI™) fuel system and variable speed fan drive. Designed for performance, durability, serviceability, and fuel economy, it meets EPA Tier 2, EU Stage II and Japan MOC exhaust emission regulations. **pg. 4**

Operator Station

The C-Series Track Loader is designed for operator comfort, convenience, and productivity. Sound suppressed ROPS cab, heating and air conditioning, an adjustable air-suspension seat with side-to-side isolator, and pilot hydraulic implement controls help reduce operator fatigue. **pg. 6**

Electronic Monitoring System (EMS III)

The Caterpillar® Electronic Monitoring System monitors hydrostatic and electrical systems, providing instant feedback on the machine condition. **pg. 8**

Special Application Arrangements

Special arrangements – Waste Handling, Shiphold and more, are available or can be designed on request, to allow the 953C to work in special applications. **pg. 13**

Work Tools and GET

✓ A large choice of buckets, Ground Engaging Tools (GET), and attachments, allow configuration of the 953C for maximum performance in virtually any job. **pg. 14**

The 953C works well in a wide range of applications. Excavating, clearing, stripping topsoil, landscape contouring, grading, dozing, backfilling, hard bank digging, carrying material, and truck loading all can be accomplished with one machine.

Reliable, durable operation. Rugged construction, self-diagnosis of electrical and power train systems, and easy maintenance help ensure extended service life with low operating costs.



Hydrostatic Drive

The hydrostatic drive with electronic control provides precise modulation for quick, smooth operation and superior maneuverability. Shorter cycle times, high efficiency, and excellent maneuverability results in increased productivity. **pg. 9**

SystemOne™ Undercarriage

- ✓ The revolutionary Cat SystemOne Undercarriage provides maximum undercarriage life and reliability no matter the application, environment or underfoot conditions. Built to last longer and require less maintenance it ensures a dramatic drop in owning and operating costs. **pg. 10**

Structure

The box-section main frame is designed specifically for the work of a track loader. It provides durability, resistance to twisting, and a solid base for all components. The Z-bar linkage offers increased breakout force and fast dump speed for enhanced productivity. **pg. 12**

Serviceability and Customer Support

The 953C design offers reduced maintenance, convenient access to components, easy diagnostic capabilities, as well as easy and economical component replacement possibilities. Cat Dealers also provide quick parts availability. **pg. 16**



✓ *New Feature*

Engine

Provides power, reliability and acts as a working counterweight in the rear of the machine, for optimum machine balance.

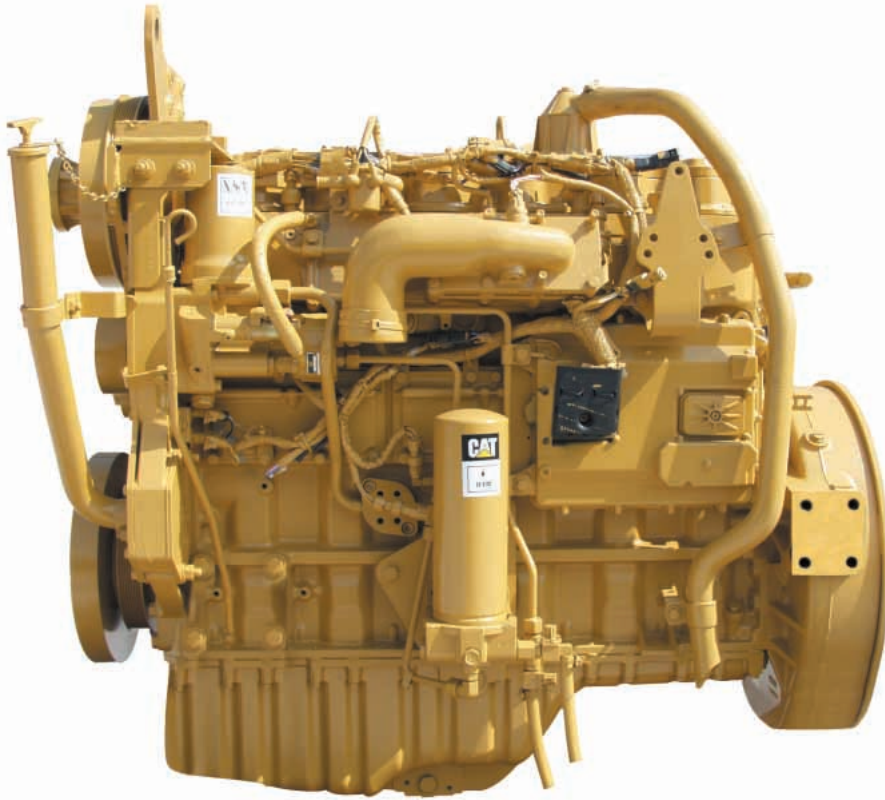

Cat 3126B Diesel Engine. The Cat 3126B diesel engine is a six cylinder, four-cycle design that provides long, effective power strokes for high torque and more complete fuel combustion. The 3126B is rated at 95 net kW (128 net hp) at 2,000 rpm. The 3126B is equipped with an electronic air inlet heater. The heater warms the air in the air inlet manifold for easier starting and reduced white smoke on cold starts.

Engine Installation. The engine is installed using rubber mounts to reduce the transfer of engine vibration to the frame and cab, lowering operator vibration, sound levels, and fatigue.

Rear Engine Location. Rear engine location allows excellent forward visibility, while serving as a working counterweight. It also helps reduce radiator plugging while providing easy service access to the engine and other major components.

Fuel System. The Hydraulic-actuated Electronic Unit Injection (HEUI) is a unique and proven high-pressure, direct injection fuel system for diesel engines. High injection pressures and short injection duration provide fast response, clean burning and added fuel savings.

Design. The fuel system design eliminates external high-pressure fuel lines, providing efficient, precise fuel delivery, and timing.

Serviceability. Unit injectors can be serviced individually, without the need to service the whole fuel system.

Fuel Priming Pump. An electrical fuel-priming pump, standard, is located between the fuel tank and the combined water separator/primary fuel filter. The dual fuel filters, water separator design, provides protection to the injection system against low-quality or contaminated fuel.

Displacement-to-Power Ratio. High displacement-to-power ratio provides extended engine life and exceptional reliability.

ADEM™ III. The Advanced Diesel Engine Management – Electronic Control Module continuously monitors important engine conditions and functions. It precisely controls each time the HEUI injects fuel into a cylinder and signals the machine Electronic Monitoring System (EMS III) if a problem occurs with the engine.

EHC Interface. The ADEM III controller interfaces with the hydrostatic drive Electronic Hydrostatic Control (EHC), when the engine is started, to determine if the parking brake switch is in the “Brake-on” position and the Speed-Direction control lever is in the “Brake-on” position in the “reverse-V” pattern.

Electronic Engine Speed Selector. The Electronic Speed Selector Switch (A), a “rocker” switch located on the left console, sets the engine rpm. The ADEM III engine controller will always start the engine in low idle. Any time the switch is activated to change the rpm of the engine, the Digital Message Display will automatically switch to the Digital Tachometer mode for 15 seconds to show the engine rpm.

Turbocharger and Aftercooler. A well-matched turbocharger and air-to-air aftercooler results in increased power. The exhaust driven turbocharger packs more air into the cylinders, while the air-to-air aftercooler cools the pressurized air from the turbocharger, making the engine intake air denser. The increased air in the cylinders results in more power, improved combustion, and reduced exhaust emissions.



Variable Speed Fan Drive. A viscous clutch demand fan drive regulates the fan speed based on the cooling system requirements. Provides lower spectator noise level and improved operator comfort along with lower fuel consumption for the machine, as the fan parasitic will be reduced during lower cooling demand. Additionally, there is less debris plugging of the radiators due to lower average airflow.

Extended Life Design. The engine features an extended life design including seven main bearings that provide a large bearing surface area to distribute force loads in the engine. Durable single piece aluminum alloy pistons are standard for long life.



L/R: hydraulic oil cooler, engine radiator, air-to-air aftercooler

Cooling System. The cooling system incorporates into a single cooling unit the hydraulic oil cooler, the engine radiator, and the air-to-air aftercooler. By locating the cooling system in the rear of the loader, they are away from the dust and debris stirred up by the bucket while working.

Starting System. The ADEM III controller controls the electric starter motor and the starter relay. The ADEM III prevents fuel from being supplied for starting until sufficient oil pressure is present. This prevents wear on the bearings due to operating without adequate lubrication.

Operator Station

Designed for operator comfort, convenience, and ease of operation throughout the workday.



1. Heating and Air Conditioning.

The air circulation system delivers filtered, pressurized, and temperature-controlled air through 10 louvered vents. Air conditioning is standard on cab-equipped machines. Heater with controls is standard on both cab and canopy-equipped machines.

2. Caterpillar Air-suspension Seat.

The Caterpillar air-suspension seat, with side-to-side isolator, is ergonomically designed and fully adjustable for maximum operator comfort and control. Cushioned side bolsters prevent side movement. The backrest centerline conforms to the operator's spinal curve. The contoured base curves away from lower back to reduce pressure. Retractable seat belt is 75 mm (3 in) wide for positive, comfortable restraint.

3. Storage Space. Storage spaces include a lockable storage box, a lunch box compartment, beverage holder, and coat hook.

4. Armrests. Adjustable armrests can be positioned up or down. The right armrest is adjustable forward and backward. Each armrest can be inclined to different angles for excellent operator comfort and control.

5. Dash Board. The newly designed smooth, rounded dashboard with integral defroster vents, provide all of the necessary functions and instrumentation within the operator's normal line of sight.

6. Hydrostatic Drive System Controls.

The system controls allow quick speed and directional changes from a single control lever for maximum maneuverability. Steering pedals can be adjusted from 35° to 50° depending on operator preference and allow precise control of each track independently and on-demand counter rotation. The brake pedal supplements dynamic hydraulic braking provided by the hydrostatic drive system. Pushing, digging, dozing performance is enhanced when the travel/work mode switch is in "work position". The engine is allowed to lug down, enhancing performance. In this mode, top machine speed is limited to 70% of maximum for ease of control in tight places.



7. Speed Switches. The speed mode switch (B) allows the operator to choose between "work mode" and "travel mode" for maximum drive speed, to best match the machine speed to various job conditions. Switching between travel and work mode takes effect immediately. The electronic engine speed selector switch (A) is used by the operator to set engine RPM.



8. Pilot Operated Controls. Pilot operated implement controls allow easier operation and greater productivity. Choice of single-lever pilot control (standard) or two-lever (optional) is available for bucket lift and dump. Automatic adjustable magnetic lift and bucket kickouts allow the operator to concentrate on positioning the machine, resulting in higher productivity.

9. Viewing Area. The viewing area includes tinted glass to reduce glare and provides an excellent visibility to the bucket, tracks, and around the engine enclosure to the rear. Sun visor, windshield wipers and washers are all standard features on the cab. The front wiper has variable speed, intermittent control.

10. Rearview Mirror. The rearview mirror is located above the front windshield, maximizing the operator's visibility.

Radio Installation Arrangement.

The optional radio installation arrangement includes a 24 to 12 volt converter and speakers. A heavy-duty AM/FM radio/cassette player is also available.

Dome Light. A dome light is located above the left door.

Electronic Monitoring System (EMS III)

The Electronic Monitoring System offers three main functions.



EMS III Functions. The Caterpillar EMS III offers three main functions. These include quick and simple calibration of the hydrostatic drive system, prevention of damage by alerting the operator if a machine fault has occurred, and monitoring of hydrostatic and electrical systems to aid service personnel in troubleshooting and repairs.

Gauge Cluster. The gauge cluster contains four gauges, which monitor:

- Engine coolant temperature
- Pump drive oil temperature
- Hydraulic tank oil temperature
- Fuel level

Alert Indicators. The alert indicator cluster groups the individual alert indicators for:

- Low fuel pressure
- Case drain filter bypass
- Charge filter bypass
- High pump drive (Splitter Box) oil temperature
- Low hydrostatic system charge pressure
- Low engine oil pressure
- Check engine detected by the ADEM III
- Low/high alternator output
- System warning for hydrostatic drive system
- Air inlet heater activated

Fluid Indicators. In addition to the ten alert indicators, there are two light indicators on the left side of the instrument panel showing low fuel and low coolant.

Digital Message Display. The digital display can show the operator's choice of hour meter, engine rpm, odometer, or service codes.

Three Level Warning System. EMS III also functions as a warning system with three levels of warning.

EMS III – Self-test. The EMS III self-test verifies that the main display module is operating properly every time the key start switch is turned from the “off” to the “on” position.

Product Link. EMS III, when coupled with the Caterpillar Product Link System, offers the possibility of making machine maintenance far easier.

Hydrostatic Drive

The electronically controlled hydrostatic drive helps provide quick response for shorter cycle times and increased productivity.

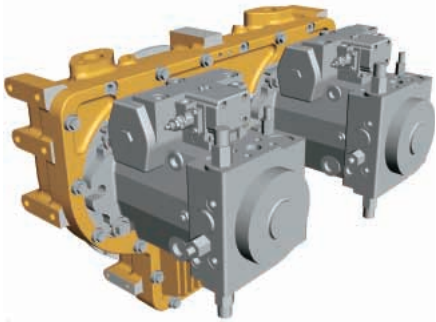

Shifting. The hydrostatic drive eliminates the need for transmission shifting, which allows the operator to concentrate on working, maneuvering, and production.

Electronic Hydrostatic Control (EHC).

The EHC maintains engine rpm in optimum operating range and balances the two track drive systems for straight travel without machine drift.

Machine Speed. The EHC automatically adjusts machine speed to give the equipment hydraulic system priority, while the hydrostatic system takes advantage of all remaining engine power.

Speed-Direction Control Lever (SDL).

The operator controls the speed of the machine and the direction of travel with a single “Speed-Direction control Lever” (SDL) located on the left console. The “reverse V” pattern of the SDL is designed to prevent an accidental full-speed-forward command when the loader encounters sudden resistance while traveling forward. If the loader should accidentally strike a dump truck, for example, inertia will tend to make the operator’s left arm move the control forward to the center of the “reverse V”, – which is the full-stop position. If we had a traditional joystick control for speed and direction, the same involuntary arm movement would command full-speed-forward, potentially increasing the damage to the truck.

Electronic Monitoring System (EMS III).

The EHC interfaces with the EMS III for system diagnostics and calibrations. It is self-diagnosing, and fully compatible with Electronic Technician (Cat ET) software. This allows quick and easy calibrations and troubleshooting.

Variable Displacement Pumps and Drive Motors.

Variable displacement pumps and drive motors are electronically controlled by the EHC, offering high efficiency and precise travel. Each track is independently driven by a separate hydraulic circuit consisting of one pump, connected by Cat XT-6™ hydraulic hose and couplings to a piston motor.

Separate Hydraulic Pumps.

Separate hydraulic pumps offer easy servicing.

Maneuverability. Independent power is provided to each track, providing great maneuverability, speed, and side slope operation. Independent power and speed for each track allows the operator to maintain full power to both tracks while turning. For additional maneuverability, the operator can use counter rotation, which allows spot turns in tight locations.

Steering. The operator steers the 953C by depressing the left (1) or right (2) steering pedal. The center brake pedal (3) is used to decrease the speed of the machine, assist in reducing rollback, and to stop the machine. Steering is accomplished by changing relative pump flows and/or motor displacements. The steering system causes one track to rotate slower than the other track. A more aggressive steering command (pushing one foot pedal down farther) will cause one track to stop while the other track continues to rotate. Pushing one pedal all the way down will cause one track to reverse direction while the other track continues to rotate in the original direction. This “counter-rotation” allows the machine to make a complete turn within its own length.

Travel Speeds. Travel speeds are infinitely variable between zero and top speed. Two speed modes, “travel” and “work”, provide two different speed ranges to best match machine speed and torque to the job conditions for maximum productivity. Maximum travel speed is increased to 10 kph (6.2 mph) when the switch is set in the travel position.

SystemOne™ Undercarriage

Exclusively for Caterpillar machines the SystemOne Undercarriage is a revolutionary new undercarriage system – from the ground up.

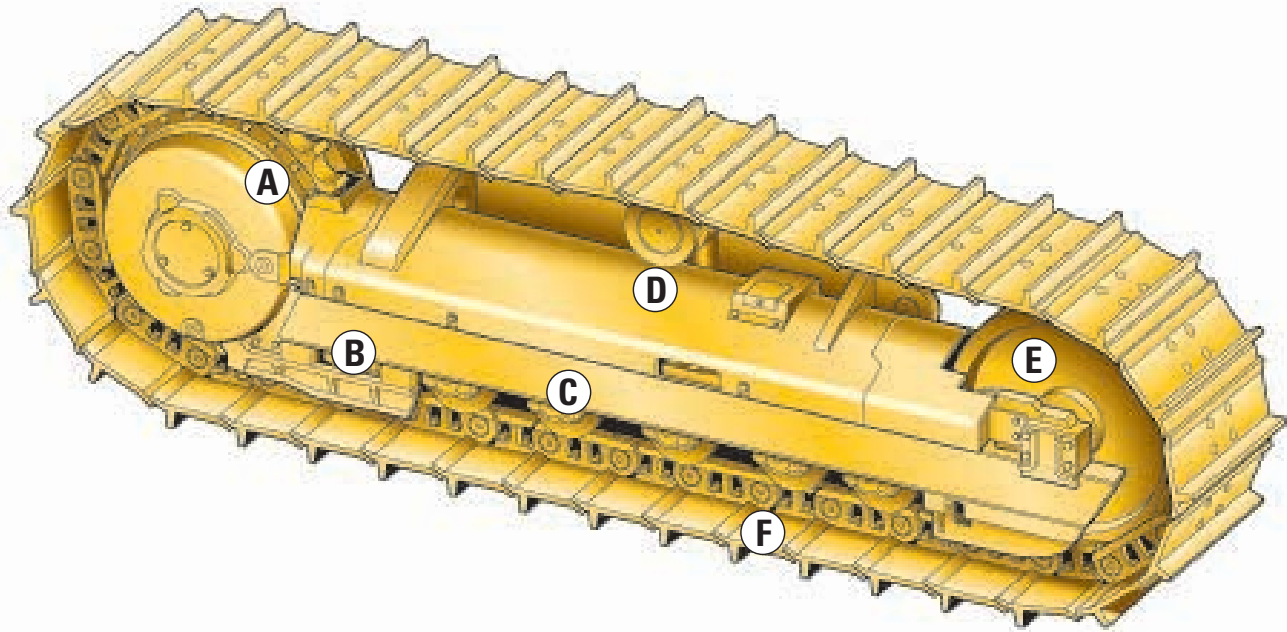

Revolutionary Undercarriage.

The revolutionary Cat SystemOne Undercarriage provides a maximum undercarriage life for all applications, environment or underfoot conditions. Cat SystemOne will deliver the longest life and greatest reliability of any undercarriage. Built to last longer and require less maintenance, it ensures greater extended life and a dramatic drop in owner and operating costs.

A) Long-life Sprocket. Extended life sprockets will outlast two or more tracks. The rotating bushing technology extends life.

B) Guiding System. Better, more rigid guiding. The guiding system contacts link rails instead of pin ends and helps keep the track within the roller system.

C) Track Roller Frames. The track roller frames are a welded, box section design, similar to the box section design of the main frame and loader tower, which provides strength and resistance to bending without adding extra weight. Six track rollers spread the machine weight over a larger area. This improves stability and provides a more comfortable ride for the operator. The increased flange diameter on the rollers provide optimum guiding.

D) Carrier Rollers. A single upper carrier roller on each side mounts to the machine mainframe. This mounting arrangement helps resist mud packing of the undercarriage. Redesigned carrier rollers are factory sealed and serviced as a unit. The larger diameter provides extended wear to better match system life.

E) Idlers. The center tread idlers contact only the bushing – not the links – eliminating scalloping and providing more guiding to the link assembly. The idlers last longer because it contacts a rotating bushing instead of a link rail.

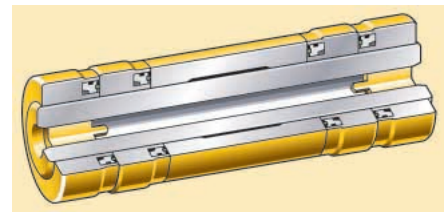

F) Cartridge Joints. Factory-sealed cartridge joints are welded to control end play. They offer improved seal integrity through an innovative new sealing system and do not depend on the link interface to remain sealed. As with all new Cat undercarriage products, they are filled with special oils.

Track Shoes. Several track shoe types tailor your machine for work in all underfoot conditions.

Extreme Service Shoes.

- Work best in moderate to high impact conditions.
- Recommended for applications where the links outlast the shoes.
- More hardened wear material than moderate service track shoes.

Moderate Service Shoes.

- Work best in low to medium abrasion conditions and low to moderate impact conditions.
- All-purpose shoes recommended for any general application.
- Provides good penetration and traction and resist wear and bending.

Multi-Grouser Shoes.

- Work best in applications that require less penetration and traction.
- Recommended for applications that require better turning capability and less ground disturbance.
- Feature two or three short grousers instead of one tall grouser.

Trapezoidal Center Hole Shoes.

- Work best in applications where packing causes the track to tighten, accelerating pin and bushing wear.
- Recommended for applications with large amounts of debris that tend to pack in the track.
- Reduces extrudable packing between the shoe and the bushing since they allow the sprocket to punch out dirt and debris.

Oscillating Track Roller Frame.

The oscillating track roller frame design decreases ground induced impact loads to the machine, increases machine stability on rough terrain, and provides a smoother, more comfortable ride for the operator.

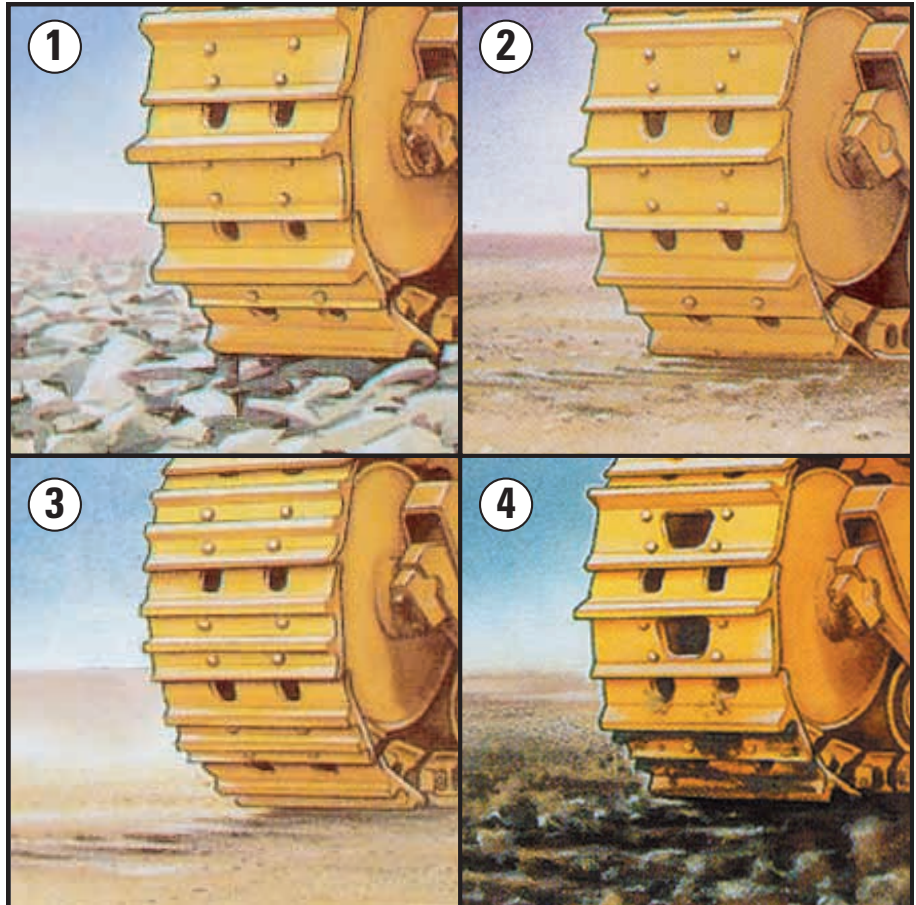

(1) Extreme Service (2) Moderate Service (3) Multi-Grouser (4) Trapezoidal Center

Pivot Shaft. Steel pivot shafts attach the rear ends of the track roller frames to the loader mainframe and carry most of the weight. The pivot shafts transfer ground induced shock loads from the track roller frames to the loader mainframe rather than through the final drives. The result is longer final drive life.

Track Adjuster. The track adjuster and mechanical recoil system uses a large recoil spring and grease filled adjustment cylinder, which allows the idler to move forward and back to maintain proper track tension as it absorbs undercarriage shock loads.

Equalizer Bar. The equalizer bar is pinned in its center to the machine mainframe and at the ends to each track roller frame. This allows the forward ends of the track roller frames to oscillate, or move vertically, to keep more track on the ground in uneven underfoot conditions. The equalizer bar also provides a more stable work platform for the operator, who will be comfortable working at faster speeds for increased productivity.

Swing-Link Idler. Permits horizontal idler movement, absorbing shock loads and maintaining proper track tension, while eliminating the need for shims and wear strips. The removal of wear strips eliminates a point of service and maintenance. Cat idler provide superior structural support.

Structure

The box-section mainframe is designed to handle heavy loads, while Z-Bar linkage maximizes breakout force, while distributing stress loads to the mainframe.



Mainframe and Loader Tower.

The mainframe and loader tower is a single, welded fabrication with castings and forgings incorporated at points of high stress to distribute those stresses over wide areas for long structural life.

Design. Strong box-section mainframe design, with continuous, deep-penetration welds resist twisting loads to protect components from excessive wear or damage without adding extra weight to the machine. The frame rails consist of two box sections, which are joined at the rear by a box-section cross member. Mounting points for the final drives, pivot shafts, and operator's platform are integrated into each mainframe side rail.

Four-Plate Loader Tower. The four-plate loader tower is integral with the basic mainframe. The loader tower distributes forces evenly from the lift arms to the mainframe, which eliminates twisting for maximum structural durability. The loader tower provides solid mounting points for lift arms, lift cylinders, and Z-Bar tilt cylinder.

Castings. Steel Castings (shown in red) are used in areas of high stress concentration. Large radius curves dissipate stresses that could cause fatigue and cracking.

Steel Frame. Fatigue resistant steel frame sections along with castings provide flexibility, durability and excellent resistance to impact loads.

Durability. Structures are designed to provide durability and extended service life to support multiple rebuilds.

Straddle Mounting. Straddle mounting supports all lift arm pivot points on both ends of the pin, eliminating twisting forces and enhancing structural durability.

Z-Bar Linkage. Breakout force is exceptionally high due to mechanical advantage of Z-bar linkage design, and hydraulic pressure applied to the head end of the tilt cylinder. Using a single tilt cylinder and linkage provides the operator a better view of the work area, bucket, and cutting edge.

Sealed Loader Linkage. The 953C linkage has fewer grease points compared to other linkage designs because every pin joint is sealed to keep grease in and dirt out. Fewer grease points and sealed pins means less downtime for maintenance allowing more working hours between servicing.

Simultaneous Lift and Dump.

Simultaneous lift and dump for fast truck loading and smooth grading, and the ability to meter material from bucket.

Lift Kickout. Automatic, adjustable magnetic lift kickout and bucket positioner allow the operator to concentrate on positioning the machine rather than the bucket. This results in higher efficiency for greater productivity.

Return-to-Dig. The "Return-to-dig" switch assembly is located on the tilt cylinder and rod. It sets the angle the bucket will return to after it is dumped, when the bucket lever is placed in the Tilt-back – hold position.

Lift Arms. The two arms are welded into a single unit, using a weld-fabricated cross-tube. The fabricated cross-tube and tilt lever use forging at high stress points to spread the loads for long life.

Special Application Arrangements

Special arrangements are available, or can be designed on request, to allow the 953C to work in special applications.



Waste Handling Arrangements. Waste Handling arrangements provide added versatility and are designed to make the 953C perform well in sanitary landfills, or waste handling applications where the machine spreads, compacts, sorts, shreds and crushes materials.

Wide Gauge Arrangement. The Wide Gauge 953C is designed for work in very soft underfoot conditions. For enhanced flotation and stability, the track gauge has been widened and wider track shoes installed. The larger track shoes increase the ground contact area for reduced ground pressure.

Shiphold Arrangement. Shiphold arrangements allow the 953C to work in the confined and harsh shiphold environment where the machine assists in the off-loading of bulk materials, such as iron ore, steel scrap, coal, minerals, and grain.

Custom Products Arrangements. Many other arrangements are available. For other custom-designed arrangements for specific applications, contact your Caterpillar Dealer.

Work Tools and GET

A variety of attachments and Ground Engaging Tools (GET) are available to maximize performance in any application.

Versatility. The large variety of tasks an operator can perform with the standard machine and Work Tools has led to the Caterpillar Track Loader's reputation for versatility.



General Purpose Bucket. The General Purpose (GP) bucket is designed for excellent loadability and long life in a broad range of applications such as hard bank excavating, stripping and stockpile loading. High-strength, low-alloy steel helps the bucket resist dents and abrasions.

General Purpose Landfill Bucket.

With the integrated trash-rack, the General Purpose Landfill (GP Landfill) bucket becomes ideal for digging, loading and carrying as well as dozing and spreading material at landfills, or loading refuse at a transfer station.

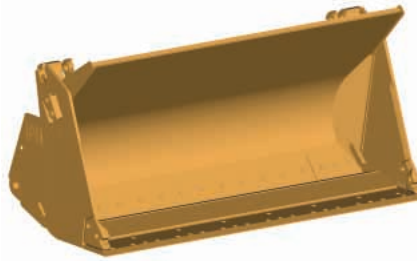

Multi-Purpose Bucket. The Multi-Purpose (MP) bucket combines the performances of a standard bucket, dozer blade and clamp. The bucket provides maximum versatility combined with strength to handle a broad range of applications, such as loading, stripping topsoil, clearing, bulldozing, picking up debris and fine grading.

Multi-Purpose Landfill Bucket.

The Multi-Purpose Landfill (MP Landfill) bucket combines the versatility of a Multi-Purpose bucket with the performance of a landfill design. Constructed with a trash-rack for increased capacity, extra strength and better load retention. Ideal for applications in the harsh refuse market, whether digging or spreading material at the landfill or grasping and loading refuse at a transfer station.



Pallet Forks. When used with a quick coupler, Pallet Forks increase the versatility of the machine. They are ideal for handling a variety of materials.



Ripper-Scarifier. The ripper-scarifier adds extra versatility to expand the application of the machine. Hinged-type, with three shanks, beam mounted with two pins pressed into each side of the mainframe. Raised and lowered with two wide-mounted cylinders. Six-pin linkage requires no lubrication.

Additional Work Tools. Beyond the GP and MP buckets and the Ripper-scarifier your Cat dealer offers: Side-Dump Buckets, Landfill Buckets, Straight Trim Blades, Pallet Forks, Extendible Material Handling Arms, and Horizontal Pin Quick Couplers.

Bucket Protection Options. Caterpillar offers several types of adapters, tips, and cutting edges, which increase bucket life and maximize performance.

- (1) Bolt-on adapters, tips, and bolt-on reversible edge segments provide a clean working floor and increase bucket capacity. Heavy-duty segments are available with 62 percent more wear material than standard segments.
- (2) Bolt-on, 2-strap adapters, and tips, including corner adapters, offer excellent penetration.
- (3) Bolt-on, reversible, cutting edges are ideal when penetration is not a consideration, such as in clean-up work or stockpiling applications.

(4) Weld-on, top-strap adapters are also available with a GP bucket. They are flush-mounted with the bottom of the cutting edge to provide a smooth bucket bottom and unrutted work surface. These adapters can be used with any of the tip options (not with a bolt-on protection system).



K Series™ Tooth System: Cat Exclusive.

The new K-Series tooth system provides longer tip and adapter life, faster cycle time with greater bucket fills and reduced machine strain.

Longer Tooth Life. Tips are installed with a slight twist and secured with a one-piece retainer, providing less tip movement and nose wear.

Stable System Geometry. Opposing, sloped rails on the adapter provide full length stabilization with minimal movement. The tip bears directly on the end of the adapter nose to absorb thrust loads, leading to better tip retention and a longer adapter life.

Easy Installation and Removal.

Opposing sloped side rails and flanks keep the tip on the nose as the retainer is being installed and removed. The one-piece vertical retainer requires low force and no special tools, allowing faster and easier removal and installation, amounting to less machine down time for tip changes.

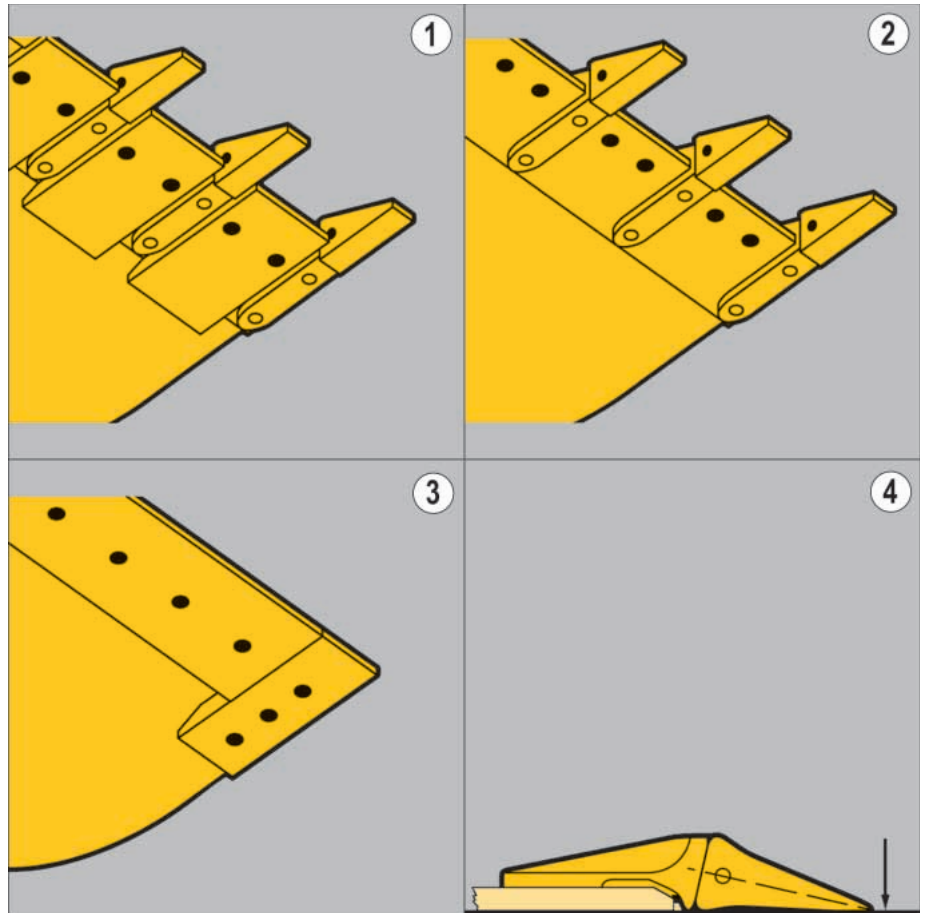

Sharper Digging Profile. Lower height at the front and the back of the nose provides a sharper profile. This provides more production, less machine strain and lower cost of machine operation.

Reversible Tips. Each tip ear has a retainer groove with a locking recess. Tips can be run in one direction, then “flipped,” or reversed, to get the maximum use of wear material from the tip.

Tip Options. Caterpillar GET offers a variety of tips to better accommodate your needs in any working environment, whether that is high impact or general-purpose applications.

These and other GET options are available from your Caterpillar Dealer.

Short Tips. Short tips are extremely strong and are for use in high impact and pry-out work such as rock.

General Duty Tips. General duty tips are for use in most general applications where breakage is not a concern.

Heavy-duty, Tips. Heavy-duty long tips are for use in general loading and excavation work. They have thirty-six percent more wear material than on standard tip. Provides increased strength, extended service life, and low cost-per-hour.

Serviceability and Customer Support

Simplified service and extended service intervals means more productive uptime.

Caterpillar. The difference counts.™



Reduced Maintenance. The 953C has many service features incorporated in the machine including:

- Caterpillar Extended Life Coolant for extended change intervals.
- Sealed electrical connectors lock out dust and moisture.
- Caterpillar XT™ hydraulic hose, in medium and high-pressure circuits, provide high abrasion resistance and far exceeds industry standards.
- O-Ring Face Seals (ORFS) hydraulic couplings eliminate fluid leaks, provide positive seals, and are reusable for lower operating costs.
- Removable cab floor panels allow access to engine, and hystat and implement pumps.

- Extended change intervals for engine and hydraulic/hystat oil.
- Scheduled Oil Sampling Fluids Analysis helps avoid unnecessary downtime. S•O•SSM fluid taps are included to make oil sampling easier.

Service Intervals. The time between fluid and filter service intervals has significantly increased, minimizing downtime and maximizing productivity.

Easy Component Access. The rear engine design and large engine access doors make it easy to reach the engine, electrical components, hydrostatic system, battery, and toolbox.

Hydraulic and fuel filters are located close to each other.

The hydrostatic drive system features separate pumps and motors for low replacement or rebuild cost. All lubrication points are accessible from ground level.

The swing-out grille, now standard, reduces downtime and the cost for cleaning, inspection, and repair of the cooling package.

Charge and Case drain Filters.

Two spin-on, hydraulic oil filters for the hydrostatic drive system, are located inside the right access door for ease of access.

Water Separator and Fuel Filter.

The water separator and fuel filter are located on the right rear of the machine.

Engine Oil Filter. The engine oil filter is located just inside the left access door of the machine. This makes filter changes easier and decreases the risk of spilling oil.

Air Filter Elements. The primary and secondary air filter elements are located on the left side of the machine in the air cleaner housing.

Batteries. The two maintenance-free batteries are located together in the battery box.

Swing-out Grille. A swing-out grille, now standard, reduces downtime and the cost for cleaning, inspection, and repair of the cooling package.

Hydraulic Oil Tank. The hydraulic oil tank, common for both the power train and the implement hydraulic systems, is located at the front of the machine between the lift arms.

Radiator Pressure Cap. The radiator pressure cap is located below the cover on top of the engine hood.

Precleaner Bowl. The precleaner bowl for the engine air intake system is located directly behind the operator's station.

Fuse Panel. The fuse panel is located inside the cab, behind the trim panel under the Speed-Direction control console.

Removable Cab Floor. Removable cab floor panels create easy access to internal components.

Product Link. This option allows the customer or dealer to obtain machine diagnostics and location from their offices. Product Link provides updates on service meter hours, machine condition, machine location, and integrated mapping/route planning.

Easy Diagnosis. The Electronic Monitoring System (EMS III) and self-diagnosing Electronic Hydraulic Control (EHC) work together to warn against both occurring and impending faults to reduce downtime.

S-O-S Fluid Taps. Simplifies drawing fluid samples for Scheduled Oil Sampling and reduces sample contamination.

Quick-Connect Fittings. The quick-connect hydraulic fittings allow quick diagnosis of the hydrostatic drive and the implement hydraulic systems. Clustered for easy access.

Service Switches. Service switches let a service technician access information in the Equipment Monitoring System (EMS III) and the Electronic Hydrostatic Control (EHC).

Product Support. Your Cat Dealer offers a wide range of services that can be set up under a Customer Support Agreement (CSA) when you purchase your equipment. The dealer will help you choose a plan that can cover everything from the machine and attachment selection to replacement. This will help you get the best return on your investment.

Service Capability. Whether in the dealer's fully equipped shop or in the field, you will get trained service technicians using the latest technology and tools.

Selection. Make detailed comparisons of the machines you are considering before you buy. How long do components last? What is the cost of preventive maintenance? What is the true cost of lost production? Your Cat Dealer can give you answers to these questions.

Purchase. Consider the financing options available as well as day-to-day operating costs. This is also the time to look at dealer services that can be included in the cost of the machine to yield lower equipment owning and operating costs over the long run.

Maintenance. More and more equipment buyers are planning for effective maintenance before buying equipment. Choose from your dealer's wide range of maintenance services at the time of your purchase. Repair option programs guarantee the cost of repairs up front. Diagnostic programs such as Scheduled Oil Sampling and Technical Analysis help avoid unscheduled repairs.

Remanufactured Components. Save money with remanufactured parts. You receive the same warranty and reliability as new products at a cost savings of 40 to 70 percent.

Engine

| | | |
|-------------------------|-----------------|---------------------|
| Engine Model | Cat 3126B ATAAC | |
| Net Flywheel Power | 95 kW | 128 hp |
| Net Power – Caterpillar | 95 kW | 128 hp |
| Net Power – ISO 9249 | 95 kW | 128 hp |
| Net Power – SAE J1349 | 95 kW | 128 hp |
| Net Power – EEC 80/1269 | 95 kW | 128 hp |
| Bore | 110 mm | 4.33 in |
| Stroke | 127 mm | 5 in |
| Displacement | 7.2 L | 439 in ³ |

- Engine ratings at 2,000 rpm.
- Meets the U.S. EPA Tier 2, European Union Stage 2 and Japan MOC exhaust emission regulations.
- Net flywheel power advertised is the power available at the flywheel when the engine is equipped with fan, air cleaner, muffler, and alternator.
- No derating required up to 4573 m (15,000 ft) altitude.

Undercarriage

| | | |
|-------------------------------------|---------------------------------|-----------------------|
| Track Shoe Type | Double Grouser, Extreme Service | |
| Track Shoe Width – Standard | 500 mm | 20 in |
| Track Shoe Width – Optional | 380 mm | 15 in |
| Track Rollers – Each Side | 6.0 | |
| Number of Shoes – Each Side | 37.0 | |
| Track on Ground | 2345 mm | 92.4 in |
| Ground Contact Area – Standard Shoe | 2.3 m ² | 3,565 in ² |
| Ground Contact Area – Optional Shoe | 1.8 m ² | 2,790 in ² |
| Ground Pressure – Standard Shoe | 65.8 kPa | 9.5 psi |
| Ground Pressure – Optional Shoe | 84.1 kPa | 12.2 psi |
| Grouser Height – Double Grouser | 35 mm | 1.4 in |
| Track Gauge | 1800 mm | 71 in |

- Super LGP arrangement available for lower ground pressure applications.
- Ground pressure is calculated using operating weight of machine with GP bucket, teeth and segments.

Drive System

| | | |
|----------------------|---|-----------|
| Type | Hydrostatic drive with infinite machine speeds to 10.0 km/h (6.2 mph) | |
| Drive Pump | Two, variable-displacement, slipper-type axial piston pumps | |
| Track Motor | Two, variable-displacement, link-type piston motors | |
| Relief Valve Setting | 44 000 kPa | 6,380 psi |

Hydraulic System – Equipment

| | | |
|---------------------------|------------|--------------|
| Type | Vane | |
| Output | 120 L/min | 31.7 gal/min |
| Main Relief Valve Setting | 24 000 kPa | 3,481 psi |
| Lift Cylinders – Bore | 120.65 mm | 4.75 in |
| Lift Cylinders – Stroke | 711 mm | 28 in |
| Tilt Cylinders – Bore | 139.7 mm | 5.5 in |
| Tilt Cylinders – Stroke | 478 mm | 18.8 in |

Hydraulic System – Pilot

| | | |
|---------------------------------------|-------------|-------------|
| Output – Maximum | 12 L/min | 3.2 gal/min |
| Relief Valve Setting | 2850 kPa | 413 psi |
| Cycle Time – Raise | 6.9 Seconds | |
| Cycle Time – Dump | 1.3 Seconds | |
| Cycle Time – Lower, Empty, Float Down | 2.6 Seconds | |

- With simultaneous raise and dump, dump time is included in raise time.

Service Refill Capacities

| | | |
|--|---------|----------|
| Fuel Tank | 233.5 L | 62 gal |
| Cooling System | 26 L | 6.9 gal |
| Crankcase (with Filter) | 18 L | 4.8 gal |
| Final Drives (each) | 15.5 L | 4.1 gal |
| Hydraulic System (Equipment, Power Train and Tank) | 110 L | 29.1 gal |
| Hydraulic Tank | 67 L | 17.7 gal |
| Pump Drive Box | 3.8 L | 1 gal |
| Pivot Shaft | 0.8 L | 0.2 gal |

Electrical System

| | |
|------------------|----------------------------------|
| Type | 24V DC |
| Battery Capacity | 750 CCA |
| Battery Voltage | 12 |
| Battery Quantity | 2 |
| Alternator | 70 amps, Heavy-Duty Brushless |

Weights

| | | |
|-------------------------------------|-----------|-----------|
| Operating Weight | 15 145 kg | 33,389 lb |
| Shipping Weight – without Bucket | 13 732 kg | 30,274 lb |

- Operating Weight: Includes coolant, lubricants, 100% fuel tank, ROPS/FOPS cab, General Purpose Bucket with long bolt-on teeth and segments and 75 kg/165 lb operator.
- Shipping Weight: Includes coolant, lubricants, 10% fuel tank, ROPS/FOPS cab and no bucket.

Buckets

| | | |
|--------------------------------|---------------------|----------------------|
| Capacity – General Purpose | 1.85 m ³ | 2.42 yd ³ |
| Capacity – Multi-Purpose | 1.6 m ³ | 2.09 yd ³ |
| Bucket Width – General Purpose | 2380 mm | 93.7 in |
| Bucket Width – Multi-Purpose | 2378 mm | 93.6 in |

- Bucket widths are based on a bare bucket.
- Bucket capacities are with long bolt-on teeth and segments.

Operating Specifications

| | | |
|-------------------|---------|---------|
| Max. Travel Speed | 10 km/h | 6.2 mph |
|-------------------|---------|---------|

Ripper Specifications

| | | |
|---|-------------|--------------|
| Type | Radial | |
| Number of Pockets | 3 | |
| Overall Width/Beam | 1952 mm | 76.9 in |
| Shank Cross Section | 50 x 109 mm | 2.0 x 4.3 in |
| Ground Clearance | 507 mm | 20 in |
| Penetration | 290 mm | 11.4 in |
| Ripping Width | 1800 mm | 70.9 in |
| Cylinders – Bore | 101.6 mm | 4 in |
| Cylinders – Stroke | 270 mm | 10.6 in |
| Addition to Machine Length due to Ripper (in Transportation Position) | 247 mm | 9.7 in |

Standards

| | |
|-----------|-----------|
| ROPS/FOPS | ROPS/FOPS |
| Brakes | Brakes |
| Cab | Cab |

- ROPS (Rollover Protective Structure) offered by Caterpillar for the machine meets ROPS criteria SAE J397 OCT95, SAE J1040 MAY94, ISO 3164:1995, ISO 3471:1994.
- FOPS (Falling Object Protective Structure) meets SAE J231 JAN81, ISO 3449:1992 Level II.
- Brakes meet the standard SAE J1026 APR90, ISO 10265:1998.
- The operator sound exposure Leq (equivalent sound pressure level) measured according to the work cycle procedures specified in ANSI/SAE J1166 MAY90 is 82 dB(A), for cab offered by Caterpillar, when properly installed and maintained and tested with the door
- Hearing protection may be needed when operating with an open operator station and cab (when not properly maintained or doors/windows open) for extended periods or in a noisy environment.
- The exterior sound pressure level for the standard machine measured at a distance of 15 meters (49.2 ft) according to the test procedures specified in SAE J88 APR95, mid-gear-moving operation, is 77 dB(A).

Dimensions

All dimensions are subject to change without notice.

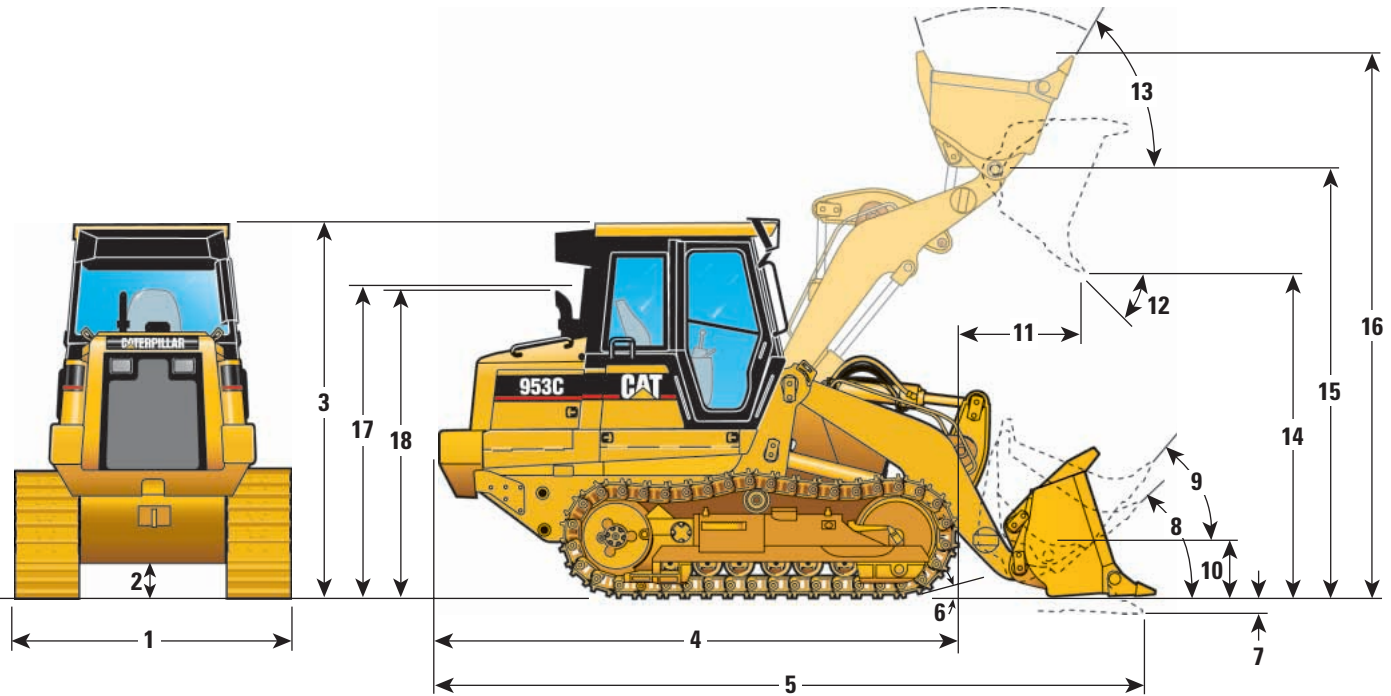

System One

| | | |
|-----------|---|--|
| 1 | Overall machine width without bucket: with standard tracks – 500 mm (19.7 in shoes) with narrow tracks – 380 mm (14.9 in shoes) | 2300 mm (90.5 in) 2060 mm (81.1 in) |
| 2 | Ground clearance from face of shoe | 410.5 mm (16.2 in) |
| | Grading angle | 74° |
| 3 | Machine height to top of cab | 3160.5 mm (124.4 in) |
| 4 | Length to front of track | 4350 mm (171.3 in) |
| 5 | Overall machine length | ◆ |
| 6 | Carry position approach angle | 15° |
| 7 | Digging depth | ◆ |
| 8 | Maximum rollback at ground | ◆ |
| 9 | Maximum rollback at carry position | ◆ |
| 10 | Bucket height in carry position | ◆ |
| 11 | Reach at full lift height | ◆ |
| 12 | S.A.E. specified dump angle | 45° (56° max.) |
| 13 | Maximum rollback, fully raised | 56° |
| 14 | Dump clearance at full lift height and 45° discharge | ◆ |
| 15 | Height to bucket hinge pin | 3595.5 mm (141.6 in) |
| 16 | Overall machine height, bucket fully raised | ◆ |
| 17 | Height to top of seat with headrest | 2624.5 mm (103.3 in) |
| 18 | Height to top of stack | 2664.5 mm (104.9 in) |

◆ Dimensions vary with bucket. Refer to Operating Specifications chart.

Operating Specifications

| | | General purpose bucket | | | | Landfill bucket | | |
|--|-----------------|------------------------|--------------------------|----------------------|--|-----------------|--------------------------|----------------------|
| | | Bare | Bolt-on teeth & segments | Bolt-on cutting edge | Flush mounted, weld-on adapters & tips | Bare | Bolt-on teeth & segments | Bolt-on cutting edge |
| Rated bucket capacity † | m ³ | 1.75 | 1.85 | 1.85 | 1.75 | 2.00 | 2.10 | 2.10 |
| | yd ³ | 2.29 | 2.42 | 2.42 | 2.29 | 2.61 | 2.74 | 2.74 |
| Struck capacity † | m ³ | 1.45 | 1.55 | 1.55 | 1.45 | — | — | — |
| | yd ³ | 1.90 | 2.03 | 2.03 | 1.90 | — | — | — |
| Bucket width – overall | mm | 2380 | 2432 | 2397 | 2438 | 2378 | 2536 | 2378 |
| | in | 93.7 | 95.7 | 94.4 | 96.0 | 93.6 | 99.8 | 93.6 |
| Bucket weight | kg | 951 | 1175 | 1101 | 1052 | 1508 | 1785 | 1626 |
| | lb | 2,097 | 2,590 | 2,427 | 2,370 | 3,325 | 3,935 | 3,585 |
| Dump clearance at full lift and 45° discharge † | mm | 2903 | 2749 | 2857 | 2748 | — | — | — |
| | in | 114.3 | 108.2 | 112.5 | 108.2 | — | — | — |
| Reach at 45° discharge angle and 2133 mm (84 in) clearance † | mm | 1518 | 1607 | 1529 | 1633 | — | — | — |
| | in | 59.8 | 63.3 | 60.2 | 64.3 | — | — | — |
| Reach at full lift and 45° discharge | mm | 974 | 1162 | 1030 | 1165 | — | — | — |
| | in | 38.3 | 45.7 | 40.6 | 45.9 | — | — | — |
| Digging depth † | mm | 96 | 131 | 121 | 96 | — | — | — |
| | in | 3.78 | 5.16 | 4.76 | 3.78 | — | — | — |
| Maximum rollback at ground | Deg | 41° | 41° | 41° | 41° | — | — | — |
| Maximum rollback at carry position | Deg | 48° | 48° | 48° | 48° | — | — | — |
| Bucket height in carry position | mm | 422 | 422 | 422 | 422 | — | — | — |
| | in | 16.61 | 16.61 | 16.61 | 16.61 | — | — | — |
| Overall machine length Bucket level on ground | mm | 5879 | 6122 | 5951 | 6125 | — | — | — |
| | in | 231.5 | 241.0 | 234.3 | 241.1 | — | — | — |
| Overall machine height with bucket at full raise | mm | 4871 | 4871 | 4871 | 4871 | 5344 | 5344 | 5344 |
| | in | 191.8 | 191.8 | 191.8 | 191.8 | 210.4 | 210.4 | 210.4 |
| Static tipping load | kg | 10 689 | 10 395 | 10 492 | 10 556 | 10 170 | 9808 | 10 034 |
| | lb | 23,565 | 22,917 | 23,131 | 23,272 | 22,421 | 21,623 | 22,121 |
| Breakout force – with tilt cylinders Bucket level at ground | kN | 136.3 | 122.7 | 123.5 | 138.1 | — | — | — |
| | lb | 30,641 | 27,584 | 27,764 | 31,046 | — | — | — |
| Operating weight* | kg | 14 921 | 15 145 | 15 071 | 15 022 | 15 558 | 15 835 | 15 676 |
| | lb | 32,895 | 33,389 | 33,226 | 33,118 | 34,229 | 34,910 | 34,560 |

* Includes coolant, lubricants, full fuel tank, ROPS cab, bucket and 75 kg/165 lb operator.

† Specifications and ratings conform to all applicable standards recommended by the Society of Automotive Engineers. SAE Standard J732 JUN92 and SAE Standard J742 FEB85 govern loader ratings.

| | Change In Operating Weight | | Change In Static Tipping Load | |
|---------------------------------------|----------------------------|---------|-------------------------------|-----------|
| ROPS canopy only (cab removed) | -350 kg | -551 lb | -332 kg | -732 lb |
| Ripper with 3 shanks (bumper removed) | +376 kg | +829 lb | +655 kg | +1,444 lb |
| Rear bumper (removal) | -207 kg | -456 lb | -423 kg | -932 lb |

NOTE: Machine stability can be affected by the addition of other attachments. Add or subtract to/from machine operating weight and static tipping load.

Operating Specifications

| | | Multi-purpose bucket | | |
|--|-----------------|----------------------|--------------------------|----------------------|
| | | Bare | Bolt-on teeth & segments | Bolt-on cutting edge |
| Rated bucket capacity † | m ³ | 1.50 | 1.60 | 1.60 |
| | yd ³ | 1.96 | 2.09 | 2.09 |
| Struck capacity † | m ³ | 1.25 | 1.35 | 1.35 |
| | yd ³ | 1.63 | 1.77 | 1.77 |
| Bucket width – overall | mm | 2378 | 2536 | 2378 |
| | in | 93.6 | 99.8 | 93.6 |
| Bucket weight | kg | 1324 | 1601 | 1442 |
| | lb | 2,919 | 3,530 | 3,179 |
| Dump clearance at full lift and 45° discharge † | mm | 2728 | 2556 | 2677 |
| | in | 107.4 | 100.6 | 105.4 |
| Reach at 45° discharge angle and 2133 mm (84 in) clearance † | mm | 1404 | — | — |
| | in | 55.3 | — | — |
| Reach at full lift and 45° discharge | mm | 949 | 1121 | 1000 |
| | in | 37.4 | 44.1 | 39.4 |
| Digging depth † | mm | 147 | 181 | 171 |
| | in | 5.79 | 7.13 | 6.73 |
| Maximum rollback at ground | Deg | 42° | 42° | 42° |
| Maximum rollback at carry position | Deg | 50° | 50° | 50° |
| Bucket height in carry position | mm | — | — | — |
| | in | — | — | — |
| Overall machine length | mm | 6036 | 6279 | 6108 |
| | in | 237.6 | 247.2 | 240.5 |
| Overall machine height with bucket at full raise | mm | 4862 | 4862 | 4862 |
| | in | 191.4 | 191.4 | 191.4 |
| Static tipping load | kg | 10 354 | 9992 | 10 218 |
| | lb | 22,827 | 22,029 | 22,527 |
| Breakout force – with tilt cylinders | kN | 107.1 | 97.4 | 97.9 |
| | lb | 24,077 | 21,896 | 22,009 |
| Operating weight* | kg | 15 374 | 15 651 | 15 492 |
| | lb | 33,894 | 34,505 | 34,154 |

* Includes coolant, lubricants, full fuel tank, ROPS cab, bucket and 75 kg/165 lb operator.

† Specifications and ratings conform to all applicable standards recommended by the Society of Automotive Engineers. SAE Standard J732 JUN92 and SAE Standard J742 FEB85 govern loader ratings.

Standard Equipment

Standard equipment may vary. Consult your Caterpillar dealer for details.

ELECTRICAL

- Alarm, back-up
- Alternator (24-volt, 70-amp)
- Batteries, Cat premium, heavy-duty (900 CCA)
- Electronic Hydrostatic Control (EHC)
- Electronic Monitoring System (EMS III)
- Lights (2), ROPS mounted, forward facing (halogen)
- Lighting system (halogen) four lights, 2 forward, 2 rear
- Power outlet, 12-volt
- Starting motor, 24-volt electric

OPERATOR ENVIRONMENT

- Adjustable steering pedal
- Air conditioner
- Armrests, adjustable
- Ashtray, lighter (24-volt)
- Cab, pressurized and sound suppressed tinted glass, (ROPS/FOPS)
- Coat hook
- Control, single lever, pilot operated for implement hydraulics
- Cup holder
- Heater and defroster
- Horn
- Instrumentation, gauges
 - Engine coolant temperature, fuel level, hydraulic oil temperature, pump drive gear box oil temperature
- Instrumentation, warning indicators
 - Air inlet temperature, case drain filter bypass, case drain filter bypass, charge oil pressure, check engine, electrical charging (too high/too low), engine oil pressure, fuel pressure, hydrostatic drive system, pump drive (splitter box) oil temperature
- Key start
- Mirror, review (internal)
- Parking brake switch, brake-on indicator light
- Radio ready, 24-volt to 12-volt converter, speakers, antenna, mounting bracket
- Seat, (cloth) air-suspension with side-to-side isolator
- Seat belt, retractable
- Sound suppression, spectator
- Speed mode switch, (work-travel)
- Storage compartments under armrests (lockable on right armrest)
- Adjustable steering pedals
- Wipers/washers (front and rear)
 - Intermittent front wiper

POWER TRAIN

- Air inlet heater
- Demand fan
- Engine, Cat 3126B HEUI diesel with ATAAC turbocharged, with ADEM III Controller
- Filters, air (radial seal)
- Fuel priming pump, electric
- Pre-cleaner, air intake
- Radiator guard, HD, perforated

UNDERCARRIAGE

- Sprocket guards
- Sprocket rims, segmented
- Track shoes, 500 mm (20.1 in) SystemOne track shoes
- Track adjuster, hydraulic
- Track guiding guards, end section
- Track idlers, lifetime lubricated
- Track rollers (6), one upper carrier roller lifetime lubricated
- Track shoes, 500 mm (19.7 in), double grouser, extreme service
- Track shoes, 500 mm (20.1 in) SystemOne

OTHER STANDARD EQUIPMENT

- Bucket positioner, automatic
- Bumper, rear
- Coolant, extended life
- Cooler, hydraulic oil
- Crankcase guard, full
- Hitch, front retrieval
- Engine enclosure, lockable doors
- Lift kickout, automatic
- O-ring face seal couplings
- Radiator grille, swing-out
- S•O•S valves
- Vandalism protection – fuel tank cap with padlock, three padlocks for front service doors and radiator cap access door
- XT Hoses

Optional Equipment

Optional equipment may vary. Consult your Caterpillar dealer for details.

Antifreeze for temperatures between -37°C (-34°F) and -50°C (-58°F)

Anti-theft, Machine Security System (MSS)

Buckets:

General purpose 1.75 m^3 (2.25 yd^3)

General purpose with flush-mounted adapters 1.75 m^3 (2.25 yd^3)

Multi-purpose 1.5 m^3 (2.0 yd^3)

Bucket cutting edge, reversible, with end bits, sharpened, bolt-on for GP or MP buckets

Bucket bolt-on adapters and tips for GP or MP bucket, set of 8, includes corner adapters

Heavy duty 166 366

General duty 160 353

Penetration 158 348

Bucket edge segments, bolt-on for GP or MP bucket

Bucket teeth, weld on, flush mounted adapters, set of 8, includes corner teeth for GP and MP buckets

Bucket tips for use with flush adapters (on GP bucket), set of 8
Heavy duty

Bumper (removal)

Canopy, ROPS (cab removed) includes rearview mirror, 2 forward facing lights, heater, vinyl seat and vandalism protection consisting of cab vandalism package plus instrument panel guard group with padlock

Controls (for equipment hydraulic system)

Two-lever controls

3rd valve for use with lines for front or rear attachments

Diverter valve for use when both front and rear lines are required

Counterweights – 2 arrangements

Light

Heavy

Drawbar hitch

Guards:

Cab/canopy lights

Heavy-duty bottom guards

Idler

Seal protection – final drive, pivot shaft, and idler seals

Track roller

Ripper/scarifier – with three ripper shanks, bumper removed

Starting aids:

Engine coolant heater, 120- or 220-volt

SystemOne™ Undercarriage:

Track, 800 mm (31.5 in) DBL GR (37 SEC)

Track, 380 mm (15 in) DBL GR (37 SEC)

Track, 500 mm (19.7 in) DBL GR, w/center hole (37 SEC)

Notes

953C Track Loader

For more complete information on Cat products, dealer services,
and industry solutions, visit us on the web at www.cat.com

© 2005 Caterpillar
All Rights Reserved
Printed in U.S.A.

Materials and specifications are subject to change without notice.
Featured machines in photos may include additional equipment.
See your Caterpillar dealer for available options.

CAT, CATERPILLAR, their respective logos and "Caterpillar Yellow,"
as well as corporate and product identity used herein, are
trademarks of Caterpillar and may not be used without permission.

AEHQ5541-02 (10-05)

CATERPILLAR[®]