



**693+** PROGRESS THROUGH DIVERSITY **SPALECK** since 1869  
conveying and separation technology

f YouTube t

The Terex Finlay 693+ Spaleck is the ultimate in mobile fine screening and separation technology. At the heart of the plant is an innovative 2-deck German designed and constructed high performance aggressive screenbox with state of the art flip flow technology on both the top and bottom decks.

Its processing capabilities and application flexibility make the machine the ultimate tracked mobile solution for the processing and separation of recycling materials such as incineration slag, shredder light and heavy fraction, scrap metal, electronic scrap, compost, clay, quarry dust, agg-lime, plastic fractions, biomass, topsoil, ore and aggregates etc.

### Features:

- ▶ Unique flip-flow on top and bottom deck guarantees first-class screening, even for difficult material.
- ▶ Double deck screen box, each deck 5.9m x 1.53m (20' x 5').
- ▶ Non blinding screening mats - less contamination.
- ▶ Dynamic wear resistant screening mats allow an efficient material flow - screwless mounted and fast changeover.
- ▶ Low maintenance, since the high acceleration on the screening mats ensures a self-cleaning effect.
- ▶ Wet, moist, dry and mixed materials e.g. recycling and skip waste fines material, compost, aggregates, waste wood, timber etc.

### Transport Dimensions



### Working Dimensions

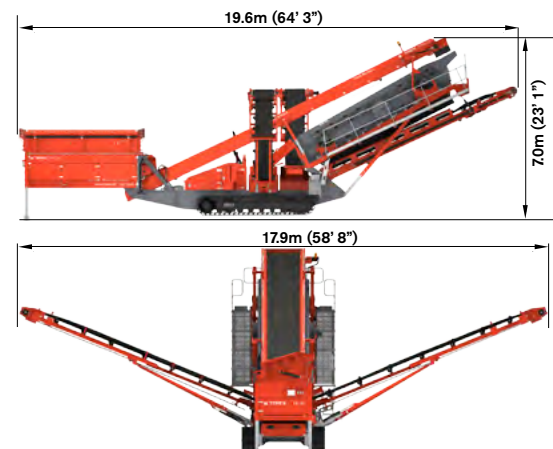

Machine Weight: \* 33,500kg (73,855lbs) \* With tipping grid



**693+** PROGRESS THROUGH DIVERSITY **SPALECK** since 1869  
conveying and separation technology

