



CONSTRUCTION LOADALLS: TOOL CARRIER RANGE

506-23 TC/509-23 TC/512-26 TC/509-45 TC/510-44 TC/510-55 TC/508-66 TC

Gross power: 74hp / 55kW – 125hp / 93 kW Lift capacity: 6000 – 12000 lbs Lift height: 23' – 66'



JCB LOADALL: ULTIMATE RETURN ON INVESTMENT.

JCB LOADALLS ARE ONE OF NORTH AMERICA'S MOST POPULAR CONSTRUCTION VEHICLES, AND IT'S NO WONDER. AVAILABLE IN A HUGE RANGE OF DIFFERENT STYLES AND SIZES, OUR VERSATILE TELEHANDLERS OFFER YOU ALL THE DURABILITY, VERSATILITY AND LOW COST OF OWNERSHIP THAT YOU NEED TO COMPETE IN TODAY'S COMPETITIVE CONSTRUCTION MARKET, WHETHER YOU'RE WORKING IN RENTAL OR ON THE SITE ITSELF.

Having pioneered the Telehandler concept back in 1977, JCB remains the world's number one Telehandler manufacturer. One reason for our success is that we are a company that manufactures a high percentage of our machines' componentry including the engine, axles, rams, chassis and booms. This means that a JCB telescopic handler is perfectly matched to our customers' requirements, our components are fully integrated and its levels of build quality is unsurpassed.

Our EcoMAX Tier 4 Final engine, for example, is a highly productive unit that's designed to work in perfect harmony with our JCB drivetrain. And we manufacture all of our own chassis and booms, which means we can ensure the highest levels of structural integrity to cope with the demands of the construction industry.

Through our worldwide dealer network you have a 'one stop shop' for parts and service. JCB Loadalls boast extended service intervals and simplified maintenance procedures. Our telescopic handlers remain highly desirable long after their initial purchase. So much so that, throughout the world, JCB telescopic handlers can drive premium residual values.

All of which means that if you want the most productive, efficient and safest telescopic handler combining ultimate strength with quick and easy servicing – delivering the lowest possible cost of ownership – then you want a JCB Loadall.



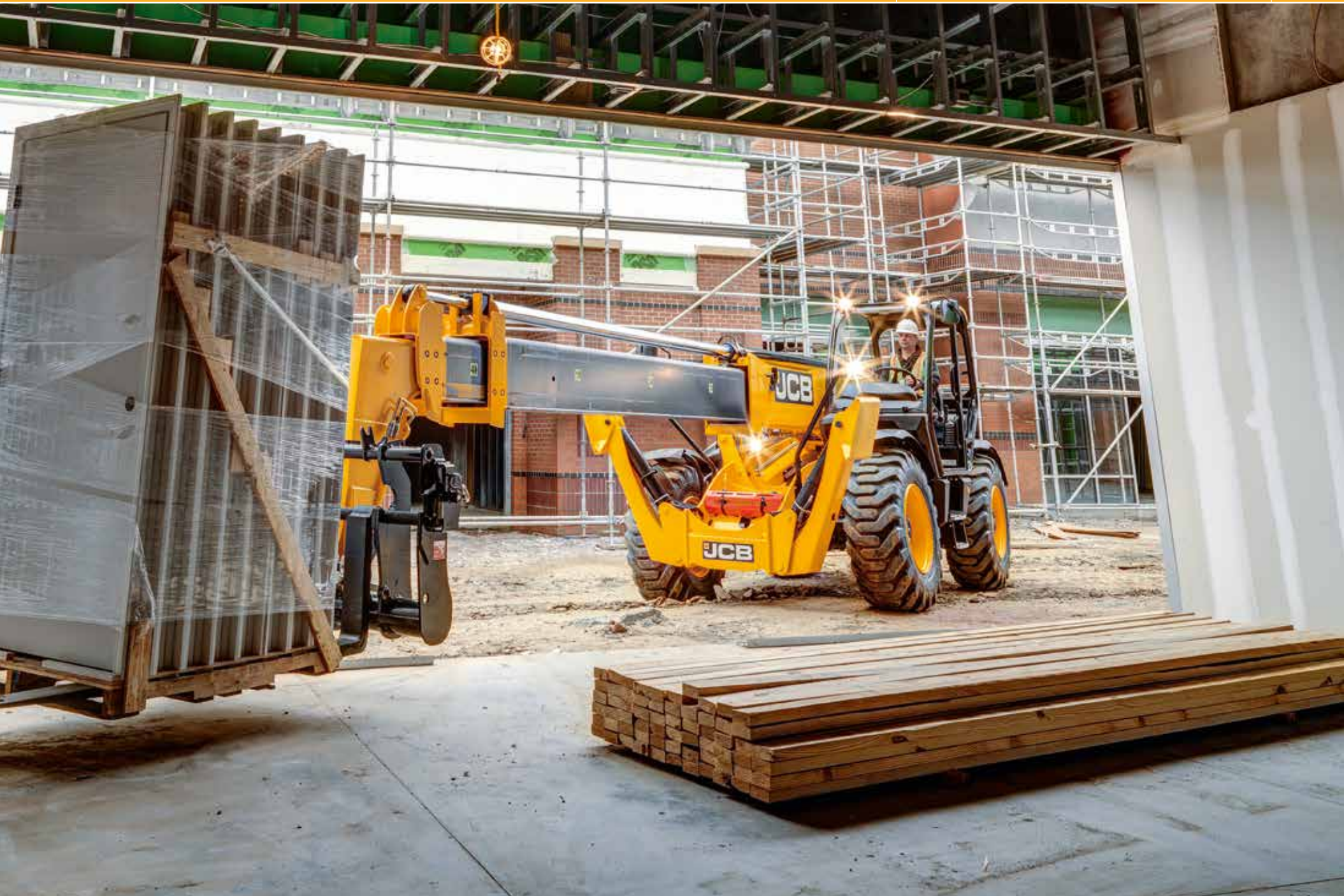

ULTIMATE PERFORMANCE, ULTIMATE PRODUCTIVITY.

JCB's efficient EcoMAX Tier 4 Final engine produces its power and torque at lower rpms for great responsiveness, and our wide range of Loadall models means you can find the perfect machine for your requirements.

THE NEW CONSTRUCTION LOADALL RANGE IS DESIGNED TO MAKE THE MOST EFFICIENT USE OF YOUR TIME AND MONEY. THAT MEANS YOU CAN EXPECT SUPERIOR PERFORMANCE, VERSATILITY, VISIBILITY, CYCLE TIMES AND ERGONOMICS. CLASS-LEADING PRODUCTIVITY IS THEREFORE, A GIVEN.



A productive machine.

1 A JCB construction Loadall is extremely maneuverable making it easy to operate in confined spaces; the compact wheelbase and large steering lock angles save you valuable travel time on site.

2 Loadalls come with 4WD as standard (optional 2WD can also be selected to minimize tire wear and fuel use during travel), helping you maintain plenty of traction and performance in soft, muddy areas. A limited slip differential in the front axle is available as an option too.

Variable geometry turbo (VGT) technology minimizes lag for excellent performance at low revs. VGT also delivers excellent speed pick-up and superior efficiency at higher revs.

Productive lifting and hydraulics.

3 JCB's optional Smoothride System (SRS)* cushions shocks from the boom, improving load retention and increasing operator comfort (and therefore productivity) when travelling at speed on the road or on uneven sites.

4 Sway frames enable an operator to make the machine level before lifting.*



*Model dependant

Productive controls.

5 For the most efficient lifting, extending and pushing – our class-leading hydraulics will give you the fastest cycle times.

On our three and four stage boom machines we fit stabilizers for increased stability and lift performance.

6 A construction Loadall has three selectable steer modes. There’s two wheel steer, which is ideal for travelling at high speed on the road; four-wheel steer for working in tight spaces; and crab steer for maneuvering close to walls and buildings.

An optional reversing fan can be used to clear dust and debris from the cooling system to maintain performance.

7 For added versatility, all JCB Loadalls are fitted as standard with a single boom auxiliary feature; which can power a wide range of attachments. The JCB quickhitch system makes attachment changes quick and easy.

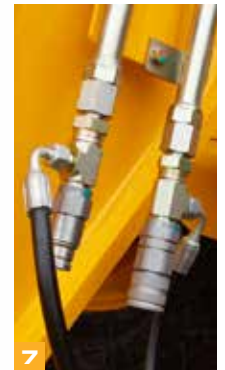

A SOUND INVESTMENT.

A JCB CONSTRUCTION LOADALL ISN'T JUST EFFICIENT TO USE – IT'S ALSO EFFICIENT TO OWN AND OPERATE. WE'VE DESIGNED THESE MACHINES TO GIVE YOU THE MAXIMUM POSSIBLE RETURN ON YOUR INVESTMENT, WITH GREAT FUEL EFFICIENCY, UNPARALLELED RESALE VALUE AND LOW RUNNING COSTS ALL PART OF THE PACKAGE.

EcoMAX efficiency.

1 109 hp (81kW) EcoMAX engines are fitted with a variable speed cooling fan that automatically reacts to ambient temperature, adjusting the fan speed for maximum economy and minimum noise.

The new 74ph (55kW) high-torque engine provides productivity and maximum efficiency.

2 Many competitive machines require a Diesel Particulate Filter (DPF) to meet Tier 4 Final legislation. JCB Loadalls use a sealed-for-life SCR system.* Among the numerous benefits of this setup is the fact that there's no loss of productivity during DPF regeneration.

3 An LED screen on the dash provides operators with useful information for efficient running, like fuel remaining, fuel used since last fill, and current average fuel consumption figures. With Tier 4 Final this will now show the Diesel Exhaust Fluid (DEF) level and current warnings.

*Model dependent

By producing high levels of power and torque even at engine speeds as low as 1300–1400rpm, EcoMAX can provide fuel-efficient matching of transmission and hydraulics.



Further efficiency.

4 A JCB construction Loadall is a great asset in so many respects, not least financially – huge global demand, plus legendary productivity, plus superb build quality equals maximum resale value.

5 High back-off brakes on the 506-23 Tool Carrier and 509-23 Tool Carrier, reduce viscous drag during travel and rehandling, which improves fuel economy by up to 2%.

We've reduced the Powershift oil level for a 1% energy boost.

6 Your engine can be remapped to run on lower-grade fuels, which means your machine (where legislation permits) can be resold into non-regulated territories, with a corresponding boost to residual values. The 74hp (55kW) engine is Tier 4 Final and requires no after treatment. This means all 74hp (55kW) engine options will not require any after treatment and therefore will not require DEF.



The 74hp (55kW) engine is Tier 4 Final and requires no after treatment. This means all 74hp (55kW) engine options are free of after treatment and therefore do not require a DPF.



THE STRONGEST CONTENDER.

IN ORDER TO BE TRULY EFFICIENT, OUR CONSTRUCTION LOADALLS ARE DESIGNED TO PROVIDE YOU WITH MAXIMUM UPTIME. TO DO THAT, WE BUILD OUR MACHINES TO BE AS TOUGH AS POSSIBLE, USING TOP QUALITY COMPONENTS AND INNOVATIVE MANUFACTURING PROCESSES. THIS, IN TURN, ENSURES MAXIMUM SERVICE LIFE.

Tough boom design.

- 1 For ultimate strength and durability, we've built in large boom overlaps of more than 3ft on all of our machines.
- 2 Hoses are routed through the boom for maximum protection.

Built-in protection.

- 3 Engine hoods on construction Loadalls are protected from damage by being side-mounted on the chassis and recessed.
- 4 Our construction Loadalls have fold-up rear lights that can be kept clear and well protected from on-site damage.
- 5 Opt for front and top screen roof guards for added protection from falling objects.

- 6 Heavy-duty axle feet help a construction Loadall absorb the stresses generated during material rehandling applications.

To protect our construction Loadalls from corrosion over the long term, we dip the cab in electrophoretic alloy before painting it.



We've fitted a tough inverted U-shaped boom pressing with fully welded closing plates. For extra strength, we've reduced the number of joints and stress points across our integrated boom nose and one-piece closing plate.

The boom on a construction Loadall is mounted low in the chassis, providing an extremely rigid structure and maximum over-the-shoulder visibility.

Centralized lift and displacement rams ensure load stresses are evenly distributed.

Durable components.

7 The new construction Loadall range's stringent testing program has included prolonged high stress loading of the chassis, boom and other key components, as well as cold climate testing and repeated transmission use over thousands of cycles.

8 The lift, tilt and extension rams are held in place by keyhole castings for even greater structural integrity.

9 The Tier 4 Final engine builds on the proven success of the JCB EcoMAX platform. Since the start of the engine program we have achieved over 200,000 hours of testing across the toughest applications and environments.

10 The one-piece fully welded chassis maximizes strength and minimizes weight.

11 At JCB, we make our own hydraulic cylinders, cabs, axles, transmissions and engines – all designed to work in perfect harmony for optimum reliability.



11



7



8



9



10

A SLICK OPERATION.

FOR A MACHINE TO PROVIDE MAXIMUM EFFICIENCY, IT NEEDS TO BE INTUITIVE AND COMFORTABLE TO OPERATE. WITH THAT IN MIND, WE'VE DESIGNED THE NEW CONSTRUCTION LOADALL RANGE TO PROVIDE THE MOST ERGONOMIC OPERATOR ENVIRONMENT POSSIBLE. AS A RESULT YOU GET THE MOST OUT OF YOUR MACHINE AND YOUR OPERATOR.

Ergonomic controls

- 1 There are simple to use twin manual levers and one manual auxiliary with optional single lever joystick.*
- 2 Backlit switches are crystal clear, even in the dark.
- 3 New instruments and a hi-res LED screen form an intuitive automotive-style layout.
- 4 To create the perfect driving position, opt for the easily adjustable tilting telescopic steering column.

*Model dependent



Comfort and convenience.

- 5 The 7-speed fan heater creates the most comfortable, productive operator environment.
- 6 The optional cab, front, rear and boom work lights provide excellent visibility.
- 7 Visibility on a construction Loadall is excellent, courtesy of direct glazing, large roof screen and low profile hood.

In addition, we have angled our roof bars to ensure maximum visibility when placing at height.

- 8 On our 510-44 TC and 510-55 TC construction Loadalls we have fitted a servo joystick for fast and precise control.

The exterior top door slam latch is new – you can now close the upper door from outside and hold the door ajar.



On bright days, a construction Loadall's standard-fit tinted cab glass will reflect 30% of the sun's energy for enhanced operator comfort.

The new-look Loadall hood isn't purely cosmetic; the cooling fan airflow is now angled upwards, reducing dust build-up.



5



6



7



8

SAFE AND SECURE.

A JCB CONSTRUCTION LOADALL CAN SAVE MORE THAN JUST TIME AND MONEY – IT CAN SAVE ITSELF AND ITS OPERATOR FROM POTENTIALLY DANGEROUS SITUATIONS. WE EQUIP OUR LOADALLS WITH STRINGENT SAFETY MEASURES TO PROTECT FROM ACCIDENTS, AS WELL AS EFFECTIVE SECURITY TECHNOLOGY TO GUARD AGAINST THEFT.



JCB LiveLink telematics real-time geofencing alerts tell you when machines move out of predetermined zones, and real-time curfew alerts inform you of unauthorised usage. Further benefits include real-time location information.

A safer choice.

- 1 Cab access is extremely safe, with three points of contact, ergonomically positioned grab handles and two steps.
- 2 A construction Loadall has hose burst check valves (HBCVs) to protect the rams from collapse in the event of a hose failure.
- 3 The low boom profile and pivot means that operators get excellent rear visibility; there's also a full set of side and rear-view mirrors to enhance all-around visibility and safety compliance.
- 4 For extra safety, bystanders are safeguarded by our standard-fit reversing alarm.



LESS SERVICING, MORE SERVICE.

NATURALLY, YOU WANT YOUR CONSTRUCTION LOADALL TO SPEND AS MUCH TIME AS POSSIBLE AT WORK, NOT BEING WORKED ON. WHICH IS WHY JCB LOADALLS HAVE LONG SERVICE INTERVALS; AND, WHEN MAINTENANCE DOES NEED TO BE CARRIED OUT, YOU'LL FIND OUR MACHINES ARE EASY AND QUICK TO SERVICE.

Minimizing downtime.

1 Most Tier 4 Final engines use a (DPF). The JCB EcoMAX doesn't. That means no worrying about loss of productivity during the regeneration process and potential extra expense in replacing DPF's.

All daily checks, greasing and serviceable components can be accessed at ground level.

2 You can access a construction Loadall's battery easily (and without specialty tools) via a lockable cover that's opened with the ignition key.

3 It's easy to fill both the diesel and DEF tanks from ground level. Both tanks also have built-in pre-filters in the filler necks to guard against dirt and contaminants.

4 A dry lubricant system means a Loadall's wear pads are extremely durable, with service intervals of 500 hours.

5 The filters on a Loadall (engine oil, hydraulic oil and fuel) are centrally located for fast, easy servicing.



UNRIVALLED REACH AND HEIGHT: THE 508-66 TOOL CARRIER.

INTRODUCING THE 508-66 TC LOADALL, THIS INDUSTRY LEADING TELESCOPIC HANDLER OFFERS INCREDIBLE REACH, A 66FT LIFT HEIGHT, ALL-TERRAIN CAPABILITY AND PROPORTIONAL BOOM EXTEND/RETRACT. ALL OF WHICH MAKES IT A HIGHLY EFFICIENT ALTERNATIVE TO A ROTO OR MOBILE CRANE, AND A PERFECT ADDITION TO ANY RENTAL OR CUSTOMER FLEET.

Rapid cycle times.

1 The 508-66 TC has a precise high-speed double boom chain extension system to maximise job site efficiency. Electro servo hydraulics and a high-flow 29 gal/min hydraulic pump also ensure fast cycle times.

2 JCB's regenerative hydraulics harness gravitational forces, diverting oil back to the rams while the arm is lowering. On the 508-66 TC this feature helps to reduce cycle times by up to 20% and fuel consumption by 4.4%.

Access all areas.

3 The formidable forward reach capability (440lbs at 52ft, 3307lbs at 29ft) means the 508-66 TC can reach across typical building foundations with ease.

A clever 5-piece boom design combines a hydraulic ram and chains to extend or retract all the sections proportionally in one fast, smooth movement. What's more, it's all operated from just one lever.

4 Sway chassis keeps the 508-66 TC level on uneven ground, what's more, the stabilizer legs provide a wide spread to maximise operator confidence and load capacity throughout the lift envelope.

5 Changing attachments is easy thanks to the combination of JCB quickhitch and an auxiliary hydraulics venting valve operated by a button in the cab.



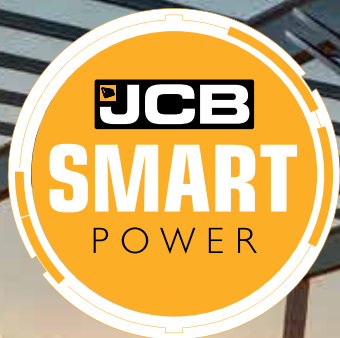

**74hp SMART POWER – No DEF, No DPF,
No hassle. The highest reach Telehandler in
North America that requires no after-treatment.**



UNRIVALLED PRODUCTIVITY: THE 512-26 TOOL CARRIER.

THE JCB 512-26 TC LOADALL IS THE HIGHEST CAPACITY MACHINE IN THE LOADALL TOOL CARRIER RANGE. WITH A MASSIVE 12,000LBS OF LIFTING CAPACITY AND A POWERFUL 125HP ECOMAX ENGINE, THE OPERATIONAL OUTPUT WILL BE HIGHER THAN EVER.

The 512-26 TC is equipped with a host of Smart Hydraulic features for improved cycle times and fuel efficiency, alongside increasing productivity and comfort.

Regenerative hydraulics.

1 Making the most out of every drop of precious fuel, gravitational forces are harnessed to make boom lowering and retract more energy.

Auto bucket control/rattle.

2 JCB's auto bucket control technology makes it easier to meter out or fully empty material from your bucket or manure fork via a feature button on the joystick.

512-26 WasteMaster.

Build specifically for those tough conditions and is fitted with additional undercarriage belly guards, fuel tank protection and semi-solid tires.



With a huge 12,000lbs capacity, 125hp and a clever series of **SMART** Hydraulics features the 512-26 TC really puts Wheel Loader productivity into Telehandlers.



LIVELINK, WORK SMARTER.

LIVELINK IS AN INNOVATIVE SOFTWARE SYSTEM THAT LETS YOU MANAGE JCB MACHINES REMOTELY – ONLINE, BY EMAIL OR ON YOUR CELL PHONE. ACCESS EVERYTHING FROM MACHINE ALERTS TO FUEL REPORTS AND HISTORY INFORMATION, WITH ALL DATA STORED AT A SECURE CENTER.

Productivity and cost benefits

By providing information like idle time monitoring and machine fuel consumption, JCB LiveLink helps reduce your fuel usage, saving money and improving productivity. Machine location information can help improve efficiency and perhaps even reduce insurance costs.

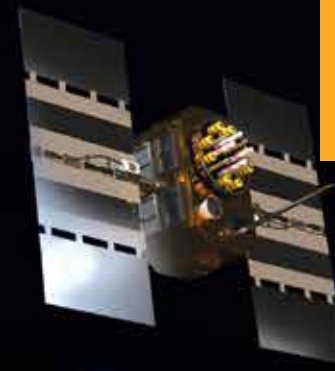

Maintenance benefits

Manage machine maintenance easily – accurate hours monitoring and service alerts improve maintenance planning, while real-time location data helps you manage your fleet. Critical machine alerts and maintenance history records are also available.



Security benefits

Keep your machine operating safely with JCB LiveLink. Real-time geofencing alerts tell you when machines move out of predetermined operating zones, and real-time curfew alerts inform you if machines are being used when they're not supposed to be. Real time location information helps you store your machines in the safest places.



VALUE ADDED.

JCB'S WORLDWIDE CUSTOMER SUPPORT IS FIRST CLASS. WHATEVER YOU NEED AND WHEREVER YOU ARE, WE'LL BE AVAILABLE QUICKLY AND EFFICIENTLY TO HELP MAKE SURE YOUR MACHINERY IS PERFORMING TO ITS FULL POTENTIAL.



1

1 Our Technical Support Service provides instant access to factory expertise, day or night, while our Finance and Insurance teams are always on hand to provide fast, flexible, competitive quotes.

2 The global network of JCB Parts Centers is another model of efficiency; with 16 regional bases, we can deliver around 95% of all parts anywhere in the world within 24 hours. Our genuine JCB parts are designed to work in perfect harmony with your machine for optimum performance and productivity.



2

3 JCB Assetcare offers comprehensive extended warranties and service agreements, as well as service-only or repair and maintenance contracts. Irrespective of what you opt for, our maintenance teams around the world charge competitive labor rates, and offer no-obligation quotations as well as fast, efficient insurance repair work.



3

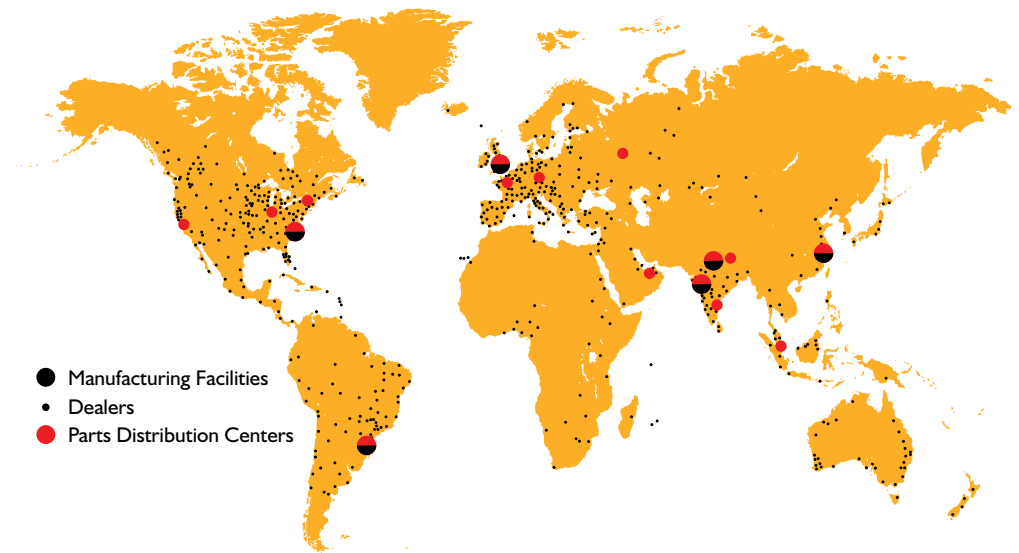

- Manufacturing Facilities
- Dealers
- Parts Distribution Centers

STATIC DIMENSIONS

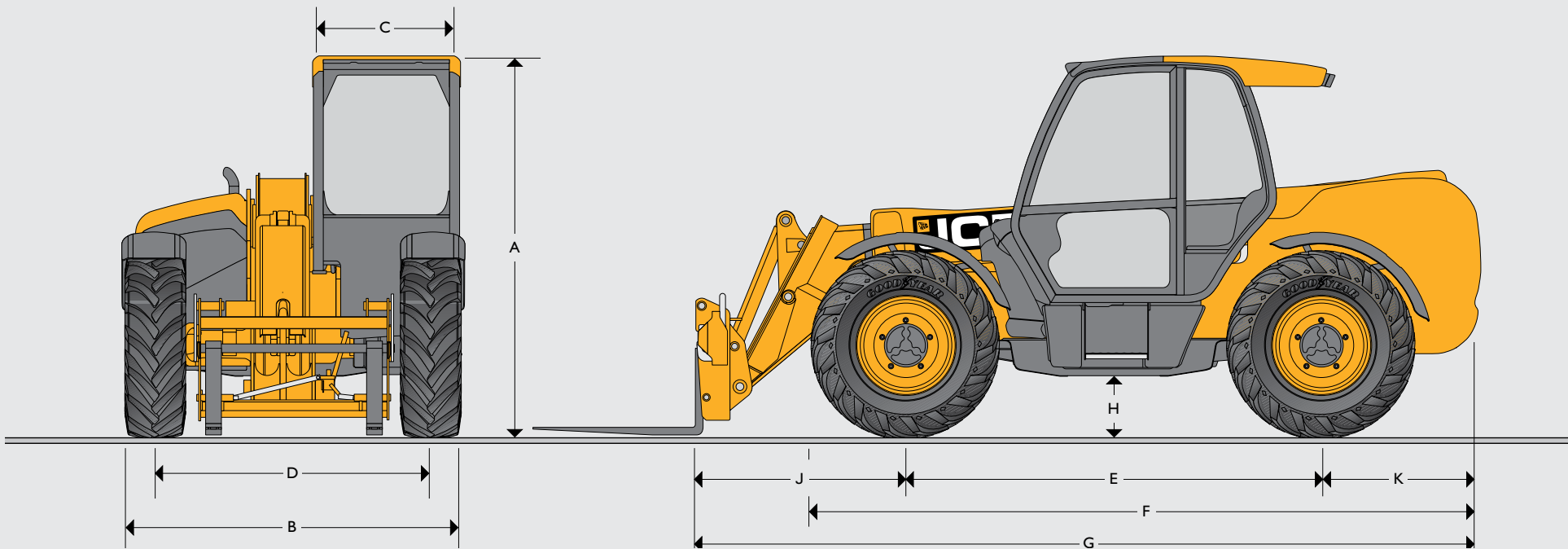

STATIC DIMENSIONS

Machine model		506-23 TC	509-23 TC	512-26 TC	509-45TC	510-44 TC	510-55 TC	508-66 TC
A Overall height	ft-in (m)	8-2 (2.49)	8-2 (2.49)	8-6 (2.59)	8-6 (2.59)	8-6 (2.59)	8-10 (2.69)	8-11 (2.72)
B Overall width (over tires)*	ft-in (m)	7-4 (2.23)	7-4 (2.23)	8-4 (2.54)	7-8 (2.35)	7-9 (2.35)	8-0 (2.44)	8-0 (2.44)
C Inside width of cab	ft-in (m)	3-1 (0.94)	3-1 (0.94)	3-1 (940)	3-1 (940)	3-1 (0.94)	3-1 (0.94)	3-1 (940)
D Front track	ft-in (m)	5-11 (1.81)	5-11 (1.81)	6-6 (1.98)	6-2 (1.90)	6-3 (1.9)	6-3 (1.9)	6-5 (1.97)
E Wheelbase	ft-in (m)	9-0 (2.75)	9-0 (2.75)	9-0 (2.75)	9-0 (2.75)	9-6 (2.9)	9-0 (2.75)	9-0 (2.75)
F Overall length to front tires	ft-in (m)	14-4 (4.38)	14-4 (4.38)	14-6 (4.42)	15-6 (4.74)	17-0 (5.18)	16-8 (5.08)	16-8 (5.09)
G Overall length to front carriage	ft-in (m)	16-4 (4.99)	16-4 (4.99)	17-3 (5.27)	20-5 (6.23)	20-6 (6.25)	20-10 (6.36)	22-4 (6.81)
H Ground clearance	ft-in (m)	1-4 (0.4)	1-4 (0.4)	1-3 (400)	1-3 (400)	1-4 (0.4)	1-4 (0.4)	1-4 (410)
J Front wheel center to carriage	ft-in (m)	4-1 (1.25)	4-1 (1.25)	-	6-11 (2.11)	5-4 (1.65)	6-3 (1.94)	7-10 (2.39)
K Rear wheel center to rear face	ft-in (m)	3-2 (0.99)	3-2 (0.99)	-	4-5 (1.37)	5-5 (1.7)	5-4 (1.67)	7-10 (2.39)
Overall width with stabilizers fully deployed	ft-in (m)	N/A	N/A	NA	8-5 (2.57)	8-9 (2.73)	11-6 (3.55)	12-6 (3.82)
Outside turn radius (over tires)	ft-in (m)	12-2 (3.7)	12-2 (3.7)	13-5 (4.10)	12-3(3.75)	13-5 (4.1)	13-5 (4.1)	13-5 (4.1)
Carriage rollback angle	degrees	42.6	42.6	47	37	41.5	39	39
Carriage dump angle	degrees	37.5	33.0	33.0	12.5	9.8	8.8	8.8
Weight	lb (kg)	15560 (7060)	17306 (7850)	24340 (11040)	23986 (10880)	24449 (11090)	27494 (12470)	28627 (12985)
Tires		15.5/80-24	15.5/80-24	480/80 R26	15.5/80-24	15.5-25	17.5-25 16 PR	17.5-25

* Dependent upon tire specified

LIFT PERFORMANCE

		506-23 TC	509-23 TC	512-26 TC	509-45 TC Stabilizers retracted	509-45 TC HiViz Stabilizers extended
Maximum lift capacity	lb (kg)	6000 (2722)	9000 (4090)	12000 (6000)	8800 (4000)	8800 (4000)
Lift capacity to full height	lb (kg)	6000 (2722)	5250 (2382)	6600 (3000)	3300 (1500)	6600 (3000)
Lift capacity at full reach	lb (kg)	3000 (1250)	3500 (1543)	3800 (1750)	440 (200)	2750 (1250)
Lift height	ft-in (m)	23-0 (7)	23-0 (7)	26-6 (7.9)	45-2 (13780)	45-2 (13780)
Reach at maximum lift height	ft-in (m)	2-0 (0.61)	2-0 (0.61)	3-0 (0.92)	10-1 (3090)	10-1 (3090)
Maximum forward reach	ft-in (m)	12-2 (3.7)	12-2 (3.7)	14-8 (4.47)	31-9 (9700)	31-9 (9700)
Reach with 1 ton load	ft-in (m)	12-2 (3.7)	12-2 (3.7)	-	-	-
Placing height	ft-in (m)	20-6 (6.3)	20-6 (6.3)	-	-	-

LIFT PERFORMANCE

		510-44 TC Stabilizers retracted	510-44 TC Stabilizers extended	510-55 TC Stabilizers retracted	510-55 TC Stabilizers extended	508-66 TC Stabilizers retracted	508-66 TC Stabilizers extended
Maximum lift capacity	lb (kg)	10000 (4535)	10000 (4535)	10000 (4535)	10000 (4535)	8800 (4000)	8800 (4000)
Lift capacity to full height	lb (kg)	6000 (2721)	10000 (4535)	3000 (1361)	5000 (2269)	1100 (500)	3300 (1500)
Lift capacity at full reach	lb (kg)	1250 (567)	2500 (1133)	0 (0)	1000 (453)	0 (0)	440 (200)
Lift height	ft-in (m)	44-3 (13.5)	44-3 (13.5)	42-10 (13.06)	54-9 (16.7)	65-7 (20)	65-7 (20)
Reach at maximum lift height	ft-in (m)	5-6 (1.71)	5-6 (1.71)	7-0 (2.13)	6-8 (2.03)	21-0 (6.4)	21-0 (6.4)
Maximum forward reach	ft-in (m)	30-8 (9.39)	30-8 (9.39)	30-0 (9.14)	41-5 (12.6)	52-1 (15.9)	52-1 (15.9)
Reach with 1 ton load	ft-in (m)	20-5 (6.25)	30-3 (9.25)	18-8 (5.76)	34-4 (10.5)	-	-
Placing height	ft-in (m)	40-1 (12.25)	43-4 (13.25)	35-9 (10.9)	53-2 (16.2)	-	-

ENGINE – JCB EcoMAX

Latest technology and advanced design provides low fuel consumption, reduced noise, high torque and power output, total reliability and minimal maintenance.

Two-stage, dry type air filter with primary and safety elements. EPA Stage IV / Tier 4 emissions compliant.

ENGINE

Machine model	506-23 TC/508-66 TC	506-23S TC/509-23S TC/509-45 TC/ 510-44 TC/510-55 TC	512-26 TC
Emissions level	Stage IV / Tier 4	Stage IV / Tier 4	Stage IV/Tier 4
Manufacturer	JCB	JCB	JCB
Displacement	liters 4.4	4.4	4.4
No. of cylinders	4	4	4
Bore size	in (mm) 4.05 (103)	4.05 (103)	4.05 (103)
Stroke	in (mm) 5.0 (132)	5.0 (132)	5.0 (132)
Aspiration	Turbocharged cooled	Turbocharged cooled & Intercooler	Turbocharged cooled
Power rating	r		
Power @ 2200rpm	hp (kW) 74 (55)	109 (81)	125 (93)
Torque rating	r		
Torque @ 1300rpm	Nm 400	516	550
After treatment	N/A	SCR & DEF	SCR & DEF

HYDRAULIC CYCLE TIMES

	506-23 TC	509-23 TC	509-45 TC	512-26 TC	510-44 TC	510-55 TC	508-66 TC
Lift	seconds 7.2	8.8	13.5	7.4	15.1	22.7	17.3
Lower	seconds 5.4	6.5	11	8.3	15.2	23.4	15.9
Extend	seconds 6.8	6.8	15.6	8.3	19.5	18.3	28.1
Retract	seconds 5	5	14.4	2.8	19.5	16.7	22.7
Bucket dump	seconds 3.5	3.5	1.7	2.8	3.2	4.2	6.1
Bucket crowd	seconds 2.9	2.9	2	3	2.5	4.6	5.9

HYDRAULICS

	Hydraulic system pressure PSI (bar)	Max. pump flow gal/min (l/min)
506-23 TC	3500 (241)	21.6 (82)
509-23 TC	3770 (260)	23.2 (88)
512-26 TC	3770 (260)	37 (140)
509-45 TC	3770 (260)	29 (110)
510-44 TC	3500 (241)	29 (110)
510-55 TC	3770 (260)	43 (162)
508-66 TC	3770 (260)	29 (110)

SERVICE CAPACITIES

Machine model	506-23 TC/509-45 TC/ 512-26 TC	509-45 TC	510-44 TC	510-55 TC	508-66 TC
Coolant	gallon (liters) 6 (23)	7 (28)	6 (23)	6 (23)	7 (28)
Engine oil sump	gallon (liters) 3.6 (14)	4 (15)	3.6 (14)	3.6 (14)	4 (15)
Hydraulic oil	gallon (liters) 29 (113)	35 (131)	35 (131)	40 (150)	48 (180)
Fuel tank	gallon (liters) 38.5 (146)	38.5 (146)	38.5 (146)	38.5 (146)	38.5 (146)
DEF tank (model dependent)	gallon (liters) 5.4 (20.8)	3 (13)	5.4 (20.8)	5.4 (20.8)	3 (13)

TRANSMISSION

Torque converter, 4 speed powershift gearbox.

Travel speed 512-26 TC: 12mph

Travel speed 506-23 TC / 509-23 TC: 18mph, 20mph (when 2/4WD select is specified).

Travel speed 509-45 TC / 510-44 TC / 510-55 TC / 508-66 TC: 18mph.

BRAKES

Service brakes: Hydraulically activated, self-adjusting, oil-immersed in-board high back-off multi-disc type on front axle.

Parking brake: Hand-operated disc brake on output of gearbox 74hp/55kW: Hand-operated disc brake on output of gearbox, 109hp (81kW) / 125hp (93kW): Oil immersed disc type.

BOOM & CARRIAGE

Boom is manufactured from high tensile steel. JCB self-levelling carriage and pallet forks and a wide range of attachments.

STEERING

Hydrostatic power steering with power track rods on both axles.

SAFETY CHECK VALVES

Fitted to carriage tilt, telescopic and boom lift cylinders.

DELUXE CAB

Quiet, safe and comfortable cab conforms to ROPS ISO 3471 and FOPS ISO 3449. Tinted glass all-around. Laminated roof screen. Roof bars, front, rear and roof screen wiper/washer and heater/screen defroster. Opening rear window. Audio-visual warning system for coolant temperature, engine oil pressure, air cleaner, battery charge, transmission oil, water in fuel temperature and pressure. Hour meter and road speed indicator. Engine temperature and fuel gauge. Full road lighting. Reversing light. Direction indicators. Adjustable steer column with stalk bar powershift change and forward reverse shuttle. Throttle and brake pedal. Adjustable suspension seat with adjacent mechanically activated park brake. Includes leveling inclinometer.

Safety canopy as above but with side glass and roof glass only (screen wiper and heater/screen defroster not applicable).

Options: Front and rear working lights, rotating flashing beacon, fire extinguisher, radial industrial tires, electrical 2/4WD select, windscreen and roof guard, radio kit, air conditioning, front wash/wipe.

Attachments: carriage options available – contact your local dealer.





ONE COMPANY, OVER 300 MACHINES.

CONSTRUCTION LOADALLS: TOOL CARRIER RANGE

506-23 TC / 509-23 TC / 512-26 TC / 509-45 TC / 510-44 TC / 510-55 TC / 508-66 TC
 Gross power: 74hp / 55kW – 125hp / 93kW Lift capacity: 6,000 – 12,000 lbs Lift height: 23' – 66'

JCB North American – Headquarters

2000 Bamford Blvd., Savannah, Georgia, 31322 Tel: (912) 447-2000

Download the very latest information on this product range at www.jcb.com

JCB inc. All rights reserved. No part of this publication may be reproduced, stored in a retrieval system, or transmitted in any form or by any other means, electronic, mechanical, photocopying or otherwise, without prior permission from JCB inc. All references in this publication to operating weights, sizes, capacities and other performance measurements are provided for guidance only and may vary dependant upon the exact specification of machine. They should not therefore be relied upon in relation to suitability for a particular application. Guidance and advice should always be sought from your JCB Dealer. JCB reserves the right to change specifications without notice. Illustrations and specifications shown may include optional equipment and accessories. The JCB logo is a registered trademark of J C Bamford Excavators Ltd.

Your nearest JCB Dealer

