



5025

Wheel Loaders 0.25 - 0.65 m³



The compact genius among wheel loaders

Compact and manoeuvrable wheel loaders for various applications. With an optimised power to weight ratio, low shipping weight and continuous high payload, the efficiency invoice with this model series is in favour of the end user.

- One-piece frame and all-wheel steering
- Hydraulic quick coupler system and parallel-controlled loading system
- Canopy with perfect circumferential visibility
- Efficient drive and low operating costs
- Versatility through third control circuit



5025

Wheel Loaders 0.25 - 0.65 m³

Technical specifications

Operating data

Bucket capacity (standard bucket)	0,25 m ³
Operating weight (CANOPY)	1.625 kg

Engine / Motor

Engine / Motor manufacturer	Yanmar
Engine performance	23 kW

Power transmission

Travel speed	20 km/h
Standard tires	28x9.00-15

Steering and operating hydraulics

Flow rate (pump)	20 l/min
Pressure (maximum)	240 bar

Kinematics

Tipping load (with bucket)	1.080 kg
Payload (S=1.25)	650 kg

Additional technical data is available in the detailed brochure in the informational material section



Dimensions

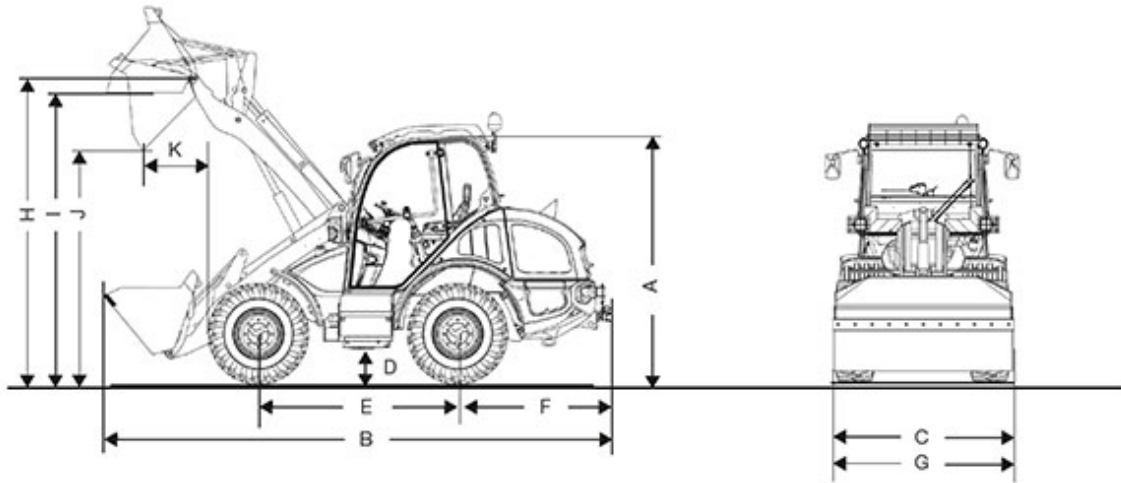

A	Height	1.980 mm
B	Length	3.890 mm
C	Width	1.177 mm
D	Ground clearance	240 mm
E	Wheelbase	1.525 mm
	Center of front axle to tip of teeth	1.250 mm
F	Center of rear axle to end of vehicle	1.115 mm
G	Bucket width	1.250 mm
H	Bucket pivot point	2.800 mm
I	Overhead loading height	2.690 mm
J	Dumping height	2.300 mm
K	Dump reach	125 mm
	Stack height	2.690 mm



Turning radius (over tyres)

1.950 mm

Information on suitable accessories can be found on our website.

The right to make changes is reserved in the interests of ongoing further developments. You can find more information on the engine power in the operator's manual. The actual power output figures may vary due to specific operating conditions.

Information on suitable accessories can be found on our website. More detailed information on engine power can be found in the operator's manual; the stated power may vary due to specific operating conditions. Subject to alterations and errors excepted. Applicable also to illustrations. Copyright © 2016 Kramer-Werke GmbH.