

# SPEC SHEET

## ICE 230B – 328B & ICE 428B – 625B

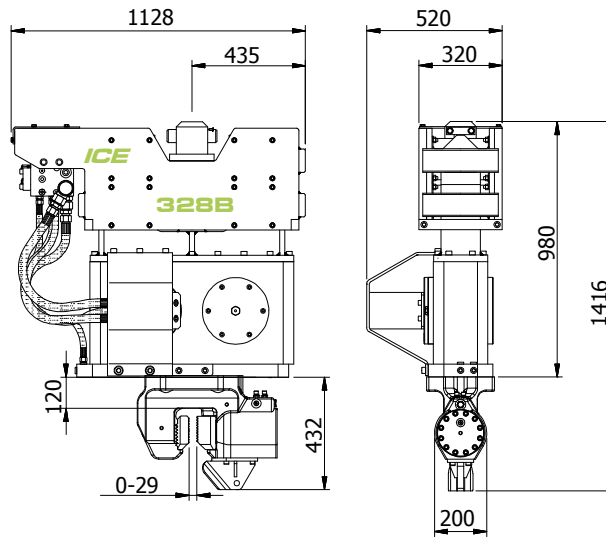

**M230B**  
M230B0013/0308  
**M328B**  
M328B0013/0308



**M428B**  
M428B0011/0308  
**M625B**  
M625B0011/0308

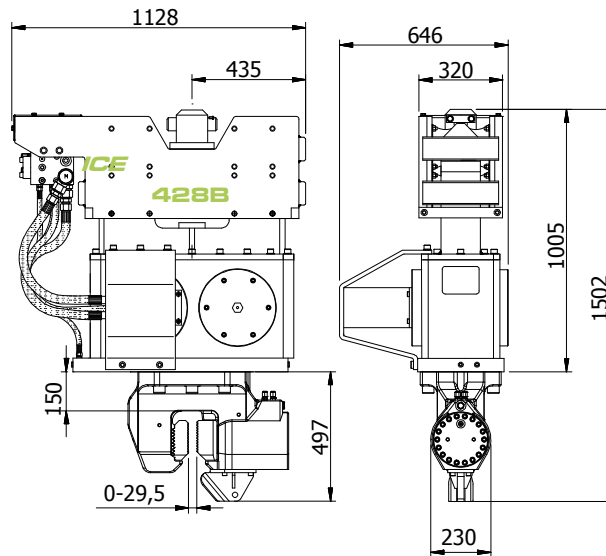

SPECIFICATIONS:	230B	328B	428B	625B	CLAMPS:	
Eccentric moment	2.2	3.2	4.0	6.0	230B – 328B	40TU
Max. centrifugal force	217	275	344	411	Universal	165 kg
Max. frequency	3000	2800	2800	2500	428B – 625B	60TU
Max. amplitude excl. clamp	7.9	11.1	12.3	17.6	Universal	250 kg
Max. amplitude incl. clamp	6.1	8.6	8.9	12.9		
Max. static line-pull	120	120	120	120		
Max. hydraulic power	53/72	65/89	98/133	117/160		
Max. operating pressure	350	350	350	350		
Max. oil flow	90	112	167	201		
Dyn. weight excl. clamp	555	575	650	680		
Dyn. weight incl. clamp	720	740	900	930		
Total weight incl. clamp	1080	1090	1280	1300		
Transport weight	1180	1190	1380	1400		

# SPEC SHEET

## ICE 230B – 328B & ICE 428B – 625B



TECHNISCHE DATEN:	230B	328B	428B	625B		KLEMMZANGE:	
Statisches Moment	2.2	3.2	4.0	6.0	kgm	230B – 328B	
Max. Fliehkraft	217	275	344	411	kN	Universalzange	40TU
Max. Drehzahl	3000	2800	2800	2500	UPM	Gewicht	165 kg
Max. Amplitude ohne Zange	7.9	11.1	12.3	17.6		428B – 625B	
Max. Amplitude mit Zange	6.1	8.6	8.9	12.9	mm	Universalzange	60TU
Max. Statische Zugkraft	120	120	120	120	kN	Gewicht	250 kg
Max. hydraulische Leistung	53/72	65/89	98/133	117/160	kW		
Max. Betriebsdruck	350	350	350	350	bar		
Max. Fördermenge.	90	112	167	201	l/min		
Dyn. Gewicht ohne Zange	555	575	650	680			
Dyn. Gewicht mit Zange	720	740	900	930	kg		
Gesamtgewicht mit Zange	1080	1090	1280	1300	kg		
Transportgewicht	1180	1190	1380	1400	kg		

SPECIFICATIONS:	230B	328B	428B	625B		PINCES:	
Moment excentrique	2.2	3.2	4.0	6.0	kgm	230B – 328B	
Max. force centrifuge	217	275	344	411	kN	Pince palplanche	40TU
Max. fréquence	3000	2800	2800	2500	t/min	Poids	165 kg
Max. amplitude sans pince	7.9	11.1	12.3	17.6		428B – 625B	
Max. amplitude avec pince	6.1	8.6	8.9	12.9	mm	Pince palplanche	60TU
Force de traction statique	120	120	120	120	kN	Poids	250 kg
Puissance hydraulique. max.	53/72	65/89	98/133	117/160	kW		
Pression de travail max.	350	350	350	350	bar		
Débit d'huile max.	90	112	167	201	l/min		
Poids dynamique sans pince	555	575	650	680			
Poids dynamique avec pince	720	740	900	930	kg		
Poids total avec pince	1080	1090	1280	1300	kg		
Poids de transport	1180	1190	1380	1400	kg		

SPECIFICATIES:	230B	328B	428B	625B		KLEMMEN:	
Excentrisch moment	2.2	3.2	4.0	6.0	kgm	230B – 328B	
Max. centrifugaalkracht	217	275	344	411	kN	Universeelklem	40TU
Max. toerental	3000	2800	2800	2500	t/min	Gewicht	165 kg
Max. amplitude excl. klem	7.9	11.1	12.3	17.6		428B – 625B	
Max. amplitude incl. klem	6.1	8.6	8.9	12.9	mm	Universeelklem	60TU
Max. statische trekkracht	120	120	120	120	kN	Gewicht	250 kg
Max. hydraulisch vermogen	53/72	65/89	98/133	117/160	kW		
Max. werkdruk	350	350	350	350	bar		
Max. oliedoorstroming	90	112	167	201	l/min		
Dyn. gewicht excl. klem	555	575	650	680			
Dyn. gewicht incl. klem	720	740	900	930	kg		
Totaalgewicht incl. klem	1080	1090	1280	1300	kg		
Transportgewicht	1180	1190	1380	1400	kg		