



## 2036 Eagle Austin-Western Portable

The Eagle Austin-Western crushers provide high strength construction without unnecessary weight making these crushers ideal for portable and skid-mounted applications.

### Features

- ❶ Hydraulic grizzly dump-over hopper is available for removing oversized material.
- ❷ Grizzly bypass chute with flop gate allows for either removal of the material that passes the grizzly deck onto an available cross-belt conveyor for stockpiling or for blending with the crushed material.
- ❸ Hydraulic lift and leveling system enables quick and easy set up and tear down.
- ❹ Totally self-contained, reliable diesel/electric or all-electric power. You won't have to worry about hydraulic leaks and failures shutting you down.
- ❺ Eagle Austin-Western 2036 Jaw Crusher.

---

### Additional Features

- Built rock solid with proven technology and designed to last with minimal service and maintenance.
- Features unique two-step, 5' grizzly deck to remove fines before crushing.
- Includes plant-mounted electrical control panel featuring pre-wired receptacles for radial stackers.
- Manage the feeder speed for continuous flow of material into the impactor with variable frequency drive (VFD).
- Includes wireless remote control for the feeder shutdown and all motor stop.

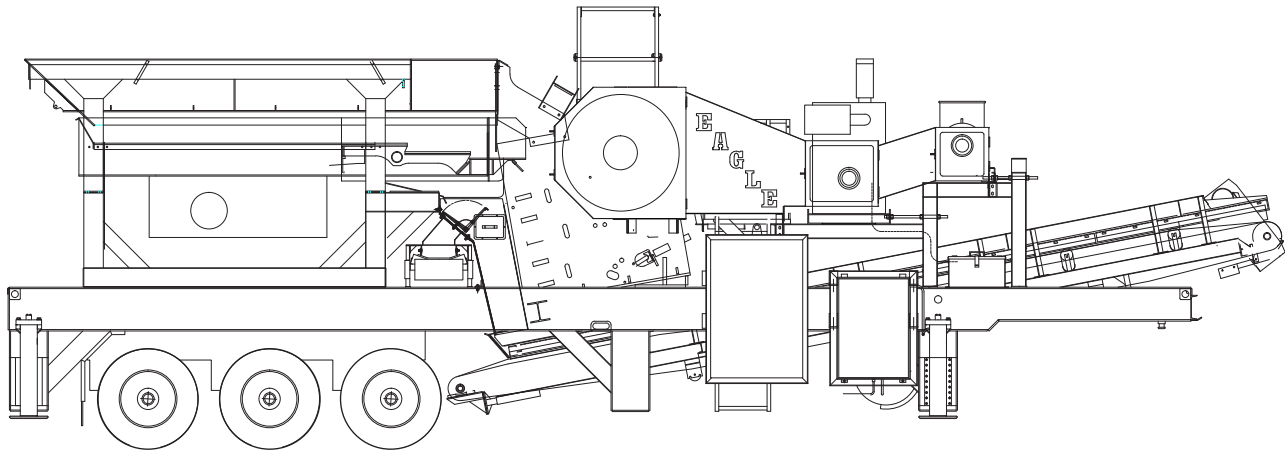

### 2036 Eagle Austin-Western Portable Specifications\*

Crusher	2036 Eagle Austin-Western
Overall Length	43' 10" / 13.4M
Gross Weight	67000lbs / 30400kg
Travel Length	39' 7" / 12.1M
Travel Width	8' 6" / 2.6M
Travel Height	13' 5" / 4.1M
Feed Hopper Capacity	11yd <sup>3</sup> / 8.4M <sup>3</sup>
Feed Hopper Capacity (Tons)	14.9T / 13.5MT
Vibrating Feeder	16' x 39" / 4.9M x 1.0M
Feeder Grizzly Deck	60" long 2 step / 1524mm long 2 step
On-Plant Power Supply Diesel	125HP / 93kW diesel engine and 40kW generator
On-Plant Power Supply Electric	100HP or 150HP / 75kW or 112kW all-electric power
Discharge Conveyor Width	36" / 914mm

### Eagle Austin-Western Jaw Crusher Specifications\*

Model	Weight (lbs / kg)	RPM	Eccentric Stroke (Inches / Millimeters)	Power Required (HP / kW)
2036 Eagle	20900 / 9500	260	1.25 / 31.75	70 - 100 / 52 - 75

\*Design specifications subject to change without notice.