

MS & AT Series Product Catalogue



MSB CORPORATION
MASTER OF SUPER BREAKERS



Smart rock mining : Blast Free

Most common mining method without blasting :
Breaking with hydraulic breakers





Full Hydraulic System : MS & AT Series

- MS Series : Masterpiece Science Series
- AT Series : Advanced Technology Series

Large Sized Breakers : MS 30/35/45/55/75AT

The large sized breakers provide us the time saving alternative in tight timeframe. They are available for the toughest demolition tasks such as the biggest demolition jobs, primary excavation in quarrying tasks, tunneling jobs and the underwater jobs with the extra kit installation. It is one of most efficient mining solutions against the blast.



Mid-Sized Breakers : MS 520H/550H/600H/700H

The robust structure and the optimized weight ratio of the mid-sized breakers by the dedicated product design are the smart choices for the jobs such as earthworks in non-residential area and secondary demolition in quarrying tasks, demolishing buildings and the underwater jobs with the extra kit installation. It is a perfect solution for digging narrow deep trenches.



Small Sized Breakers : MS 200H/220H/250H/255H/300H/400H/460H

The small breakers are highly productive choices for the jobs such as excavation work, highway and road maintenance, demolitions in urban area and building refurbishment.



AT Series



■ Technical Specification

Specification	Unit	MS AT Series				
		MS 30AT	MS 35AT	MS 45AT	MS 55AT	MS 75AT
Working Weight 1)	kg	2440	2950	3750	5500	7500
	lb	5380	6500	8270	12120	16530
Impact Rate	bpm	350~450	300 - 450	300 - 400	300 - 400	300 - 400
Operating Pressure	bar	130 - 150	130 - 150	130 - 150	130 - 150	140 - 160
	psi	1885 - 2175	1885 - 2175	1885 - 2175	1885 - 2175	2030 - 2320
Relief Pressure	bar	180 - 200	180 - 200	180 - 200	180 - 200	190 - 210
	psi	2610 - 2900	2610 - 2900	2610 - 2900	2610 - 2900	2755 - 3045
Oil Flow	l / min	170~200	190 - 220	210 - 240	250 - 305	300 - 400
	gal / min	44~52	50 - 58	55 - 63	66 - 80	79 - 105
Accumulator Pressure	bar	40	40	40	40	50
	psi	580	580	580	580	725
Tool Diameter	mm	150	165	175	180	205
	inch	5.91	6.50	6.89	7.09	8.07
Pressure Line Size [IN] (Hose Connection)	mm	25	25	25	32	38
	inch	1	1	1	1 1/4	1 1/2
Return Line Size [OUT] (Hose Connection)	mm	32	32	32	38	51
	inch	1 1/4	1 1/4	1 1/4	1 1/2	2
Carrier Weight Range 2)	ton	28 - 33	30 - 45	40 - 55	50 - 75	70 - 100
	lb	61700 - 72820	66100 - 99200	88100 - 121200	110200 - 165300	154300 - 220400

- 1) Working Weight : Included top bracket, one tool, pin, bush
- 2) Check the lifting capacity of the main carrier from the carrier manual and the carrier manufacturer.
- 3) Some numeric figures are calculated with the round off for the easier understanding for the customer preference.

■ Competitive Feature List : AT Series

Series	Size	Model	Oil Flow Control (OFC) Valve	Super Anti Blank Firing (SABF) System	Underwater Application (UA)	All-in-One Type of Upper Bushing & Thrust Ring	Accumulator System	180° Rotating Housing	Soundproof Housing Application (SHA)	Manual Autogrease System I (Powercell)	Autogrease System II (Side Mounted Refiller)	Dust Protector (Wiper Seal)	Replaceable Inner Bushing Sleeve (RIBS)	Easy Pass Valve (Oil Traffic Control)
MS AT Series	Large	MS 30AT	●	●	●	●	●	●	●	●	●	●	●	●
		MS 35AT	●	●	●	●	●	●	●	●	●	●	●	●
		MS 45AT	●	●	●	●	●	●	●	●	●	●	●	●
		MS 55AT	●	●	●	●	●	●	●	●	●	●	●	●
		MS 75AT	●	●	●	●	●	●	●	●	●	●	●	●

※ Note 1: Some competitive features may not be available, please consult this concern to MSB corporation for the availability.
 Note 2: ● Option.

AT Series Section Feature (Large Size : MS 30/35/45/55/75AT)

1 N2 Gas Charged Accumulator

Rechargeable N2 gas accumulator to assist power stroke and to reduce the spikes from the hydraulic circuit of the excavator.

2 Auto Grease Refiller

Compact auto grease refiller is equipped as an optional feature. Easy daily refill is serviced and continuous greasing is available as long as the breaker is operated.

3 Piston

Most efficient design for maximum energy transfer and recoil reduction as well as ideal match of tool and piston diameters. It transfers highest shock wave into the breaking objects.

4 Symmetrically Rotatable & Soundproof Housing

180° rotating housing will extend the lifespan of the housing from the one side wear. It also proves to save the operating cost with such conversion.

5 Underwater Application(UA)

Air line for underwater use (Not shown on the illustration)

6 Super Anti Blank Firing (SABF) System

SABF increases the lifespan of all components subject to wear and fatigue and reducing stress for the arm of the main carrier and the breaker. (Not shown on the illustration)

7 Round Edge Shaped Housing Bottom Plate

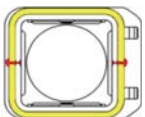

Abrasion-resistant plate delivers breaker protection.

8 Working Tool

Heat treated and optimal length for efficient breaking.

19 Efficient Power Transfer (Piston to tool)

Optimum transfer of blow energy into the material and the reduction of the recoil.

18 Top Buffer

Vibration absorber to prevent the impulses between the carrier and the breaker.

17 Side(Tie) Rods



Shorter and fully closed side (tie) rods enlarges the durability and the optimal load carrying capacity is designed.

16 Oil Flow Control(OFC) Valve



Controls the flow of hydraulic oil for maximum performance regardless of the flow variations.

15 Double Side Buffers

Side vibration absorber and side suspension device to protect the powercell. Convenient installation and replacement for easier serviceability.

14 Unique Cylinder Design



Upper round & bottom square shaped cylinder design improves stable operation to increase the product durability and to reduce the unnecessary damages such as scratches.

13 Wearing Plates

Employment of wear resistant plates between cylinder, front head and housing increases the overall product durability.

12 All-in-One Type of Upper Bushing and Thrust Ring Integration

Convenient one set and easier maintenance and serviceability without disassembly of powercell.

11 Dust Protector and Replaceable Inner Bushing Sleeve

Option package : dust wiper seal and inner bushing sleeve are also available to save the operating cost down.

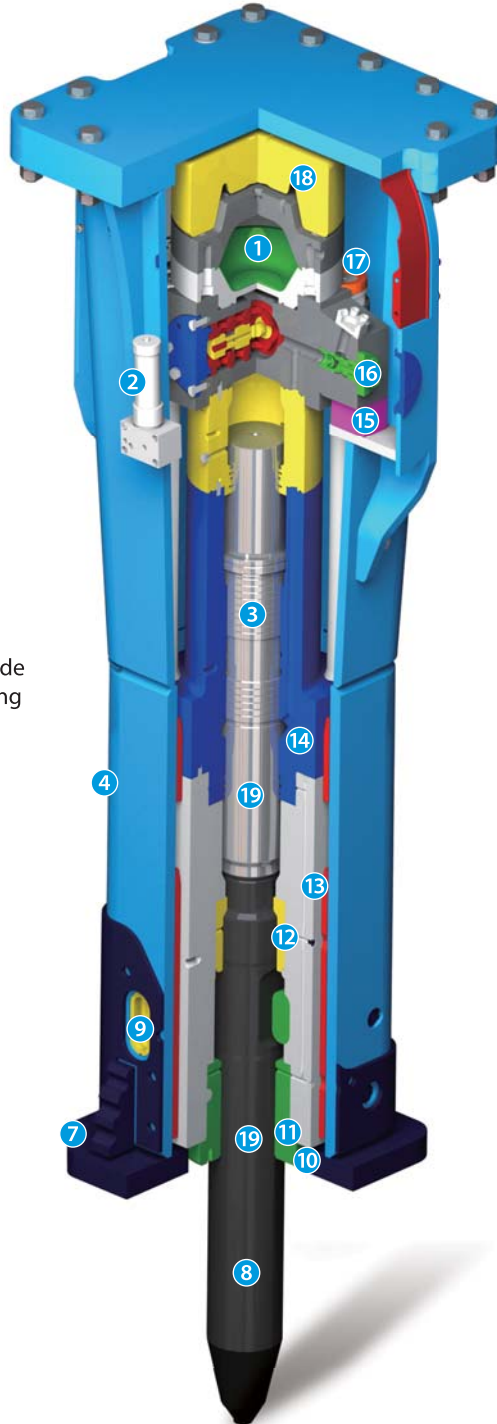

9 Dual Tool Retainer Pins

Correct tool alignment and dispersion of tool wear.

10 Field Replaceable Tool Bushing

Convenient for field replacement and protect the front head.

※ Note : some features may be adjusted due to the drawing updates by the manufacturer.

MS Mid-Sized Series



Technical Specification

Specification	Unit	MS Mid-Sized Series			
		MS 520H BOX	MS 550H BOX	MS 600H BOX	MS 700H BOX
Working Weight	kg	1200	1500	1734	2250
	lb	2645	3306	3822	4960
Impact Rate	bpm	400 - 500	400 - 500	400 - 500	400 - 500
Operating Pressure	bar	120 - 140	120 - 140	120 - 140	130 - 150
	psi	1740 - 2030	1740 - 2030	1740 - 2030	1885 - 2175
Relief Pressure	bar	170 - 190	170 - 190	170 - 190	180 - 200
	psi	2465 - 2755	2465 - 2755	2465 - 2755	2610 - 2900
Oil Flow	l / min	80 - 100	110 - 150	130 - 150	170 - 200
	gal / min	21 - 26	29 - 39	34 - 39	44 - 52
Accumulator Pressure	bar	40	40	40	40
	psi	580	580	580	580
Tool Diameter	mm	110	120	130	140
	inch	4.33	4.72	5.11	5.51
Pressure Line Size [IN] (Hose Connection)	mm	19	25	25	25
	inch	3/4	1	1	1
Return Line Size [OUT] (Hose Connection)	mm	25	25	25	32
	inch	1	1	1	1 1/4
Carrier Weight Range 2)	ton	14 - 18	18 - 25	22 - 28	25 - 31
	lb	30800 - 39600	39600 - 55100	48500 - 61700	55100 - 70500

1) Working Weight : Included top bracket, one tool, pin, bush

2) Check the lifting capacity of the main carrier from the carrier manual and the carrier manufacturer.

3) Some numeric figures are calculated with the round off for the easier understanding for the customer preference.

Competitive Feature List : MS Series

Series	Size	Model	Oil Flow Control (OFC) Valve	Super Anti Blank Firing (SABF) System	Underwater Application (UA)	180° Rotating Housing	Soundproof Housing Application (SHA)	Manual Autogrease System I (Powercell)	Autogrease System II (Side Mounted Refiller)	Dust Protector (Wiper Seal)	Replaceable Inner Bushing Sleeve (RIBS)	Easy Pass Valve (Oil Traffic Control)
MS Series	Mid	MS 520H	●	●	●	●	●	●	●	●	●	●
		MS 550H	●	●	●	●	●	●	●	●	●	●
		MS 600H	●	●	●	●	●	●	●	●	●	●
		MS 700H	●	●	●	●	●	●	●	●	●	●

※ Note 1: Some competitive features may not be available, please consult this concern to MSB corporation for the availability.

Note 2: ● Option.

MS Series Section Feature (Mid-Size : MS 520/550/600/700H)

1 N2 Gas Charged Accumulator

Rechargeable N2 gas accumulator to assist power stroke and to reduce the surge pressure and the spikes from the hydraulic circuit of the excavator.

2 Auto Grease Refiller

Compact auto grease refiller is equipped as an optional feature. Easy daily refill is serviced and continuous greasing is available as long as the breaker is operated.

3 Piston

Most efficient design for maximum energy transfer and recoil reduction as well as ideal match of tool and piston diameters. It transfers highest shock wave into the breaking objects.

4 Symmetrically Rotatable & Soundproof Housing

180° rotating housing will extend the lifespan of the housing from the one side wear. It also proves to save the operating cost with such conversion.

5 Underwater Application(UA)

Air line for underwater use

6 Super Anti Blank Firing (SABF) System

SABF increases the lifespan of all components subject to wear and fatigue and reducing stress for the arm of the main carrier and the breaker. (Not shown on the illustration)

7 Dual Tool Retainer Pins

Correct tool alignment and dispersion of tool wear.

8 Housing Bottom Plate

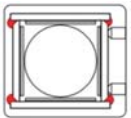

Abrasion-resistant plate delivers breaker protection.

9 Working Tool

Heat treated and optimal length for efficient breaking.

18 Efficient Power Transfer (Piston to tool)

Optimum transfer of blow energy into the material and the reduction of the recoil.

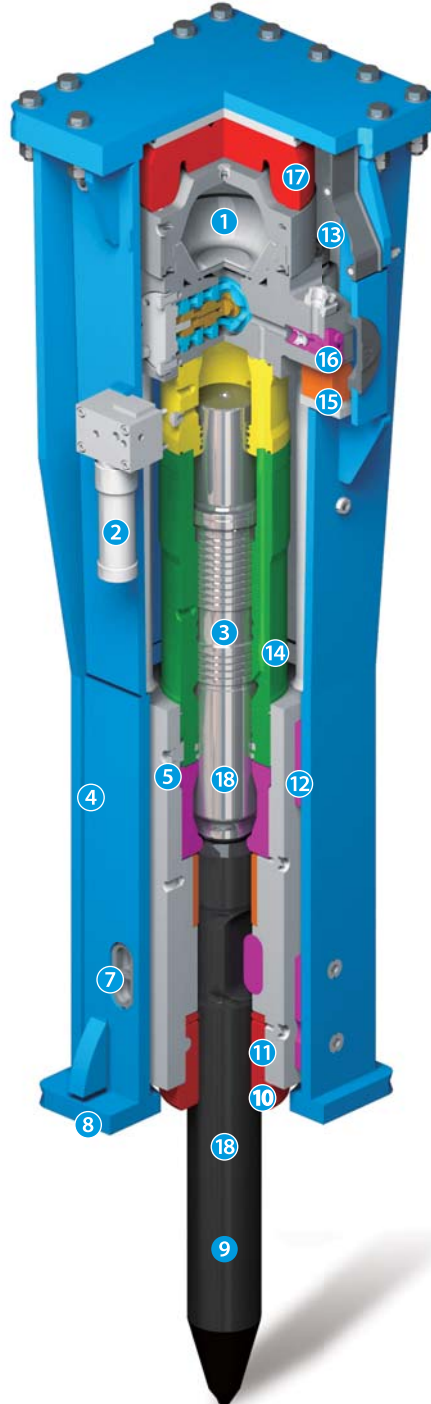

17 Top Buffer

Vibration absorber to prevent the impulses between the carrier and the breaker.

16 Check Valve (Oil Back Flow Control)



Prevents back oil flow and reduces unnecessary pulsation spikes from the hydraulic circuit for the stable operation.

15 Double Side Buffers

Side vibration absorber and side suspension device to protect the powercell. Convenient installation and replacement for easier serviceability.

14 3 Stage Cylinder Design



3 stage rounded cylinder design improves stable operation to increase the product durability and to reduce the unnecessary damages such as scratches, the flow variations.

13 Side(Tie) Rods



Fully closed side (tie) rods enlarges the durability and the optimal load carrying capacity is designed.

10 Field Replaceable Tool Bushing

Convenient for field replacement and protect the front head.

11 Dust Protector and Replaceable Inner Bushing Sleeve

Option package : dust wiper seal and inner bushing sleeve are also available to save the operating cost down.

12 Wearing Plates

Employment of wear resistant plates between cylinder, front head and housing increases the overall product durability.

※ Note : some features may be adjusted due to the drawing updates by the manufacturer.

MS Small Sized Series



※ Open / Box (Soundproof) housing are all available in MS Small Sized Series.

■ Technical Specification

Specification	Unit	MS Small Sized Series													
		MS 200H		MS 220H		MS 250H		MS 255H	MS 300H		MS 400H		MS 460H		
		OPEN	BOX	OPEN	BOX	OPEN	BOX	BACKHOE	OPEN	BOX	OPEN	BOX	OPEN	BOX	
Working Weight	kg	285	325	330	-	410	430	355	470	490	670	665	830	890	
	lb	630	720	730	-	905	950	785	1040	1080	1480	1465	1830	1965	
Impact Rate	bpm	500-1000		500-1200		520-1000		520-1000		500-900		350-700		350-650	
Operating Pressure	bar	110-130		110-130		110-130		110-130		110-130		120-140		120-140	
	psi	1595-1885		1595-1885		1595-1885		1595-1885		1595-1885		1740-2030		1740-2030	
Relief Pressure	bar	160-180		160-180		160-180		160-180		160-180		160-180		160-180	
	psi	2320-2610		2320-2610		2320-2610		2320-2610		2320-2610		2320-2610		2320-2610	
Oil Flow	l/min	40-50		40-90		60-85		60-85		60-85		70-90		70-100	
	gal/min	10-13		10-24		15-23		15-23		15-23		18-24		18-26	
Accumulator Pressure	bar	60		60(High)/10(Low)		40		40		60		60		60	
	psi	870		870(High)/145(Low)		580		580		870		870		870	
Tool Diameter	mm	63		70		75		75		85		95		100	
	inch	2.67		2.75		2.95		2.95		3.34		3.74		3.93	
Pressure Line Size [IN] (Hose Connection)	mm	12		19		19		19		19		19		19	
	inch	1/2		3/4		3/4		3/4		3/4		3/4		3/4	
Return Line Size [OUT] (Hose Connection)	mm	12		19		19		19		19		19		19	
	inch	1/2		3/4		3/4		3/4		3/4		3/4		3/4	
Carrier Weight Range 2)	ton	2-6		3-7		3-8		3-8		5-10		7-12		10-16	
	lb	4400-13200		6600-15400		6600-17600		6600-17600		11000-22000		15400-26400		22000-35200	

1) The working weight includes a standard working tool and top bracket.

2) Check the lifting capacity of the main carrier from the carrier manual and the carrier manufacturer.

3) Some numeric figures are calculated with the round off for the easier understanding for the customer preference.

■ Competitive Feature List : MS Series

Series	Size	Model	Oil Flow Control (OFC) Valve	All-in-One Type of Upper Bushing & Thrust Ring	Accumulator System	Soundproof Housing Application (SHA)	Manual Autogrease System I (Powercell)	Autogrease System II (Side Mounted Refiller)	Easy Pass Valve (Oil Traffic Control)	
MS Series	Small	MS 200H	●	●	●	●	●	●	●	
		MS 220H	●	●	●	●	●	●	●	
		MS 250H	●		●	●	●	●	●	●
		MS 255H	●		●	●	●	●	●	●
		MS 300H	●		●	●	●	●	●	●
		MS 400H	●		●	●	●	●	●	●
		MS 460H	●		●	●	●	●	●	●

※ Note 1: Some competitive features may not be available, please consult this concern to MSB corporation for the availability.

Note 2: ● Option.

MS Series Section Feature (Small Size : MS 200/220/250/255/300/400/460H)

1 N2 Gas Charged Accumulator

Rechargeable N2 gas accumulator to assist power stroke and to reduce the surge pressure and the spikes from the hydraulic circuit of the excavator.

2 Piston

Most efficient design for maximum energy transfer and recoil reduction as well as ideal match of tool and piston diameters. It transfers highest shock wave into the breaking objects.

3 Efficient Power Transfer (Piston to tool)

Optimum transfer of blow energy into the material and the reduction of the recoil.

4 Base Buffer

Vibration absorber and suspension device to protect the powercell.

5 Effective Swivel Bar

High pressure (in) and low pressure (out) swivel bar increase hose lifespan (Not shown on the illustration and available in MS250/255/300)

6 Auto Grease Refiller

Compact auto grease refiller is equipped as an optional feature. Easy daily refill is serviced and continuous greasing is available as long as the breaker is operated (Not shown on the illustration).

7 Housing Bottom Plate

Abrasion-resistant plate delivers breaker protection.

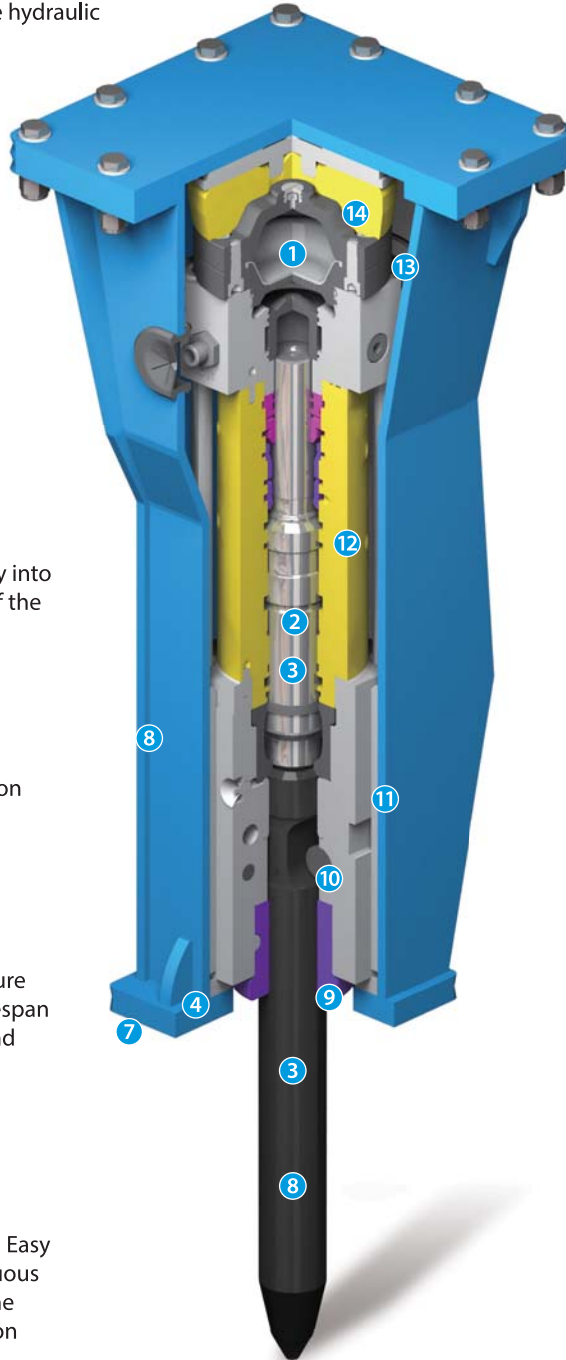

14 Top Buffer

Vibration absorber to prevent the impulses between the carrier and the breaker.

13 Side(Tie) Rods

Fully closed side (tie) rods enlarges the durability and the optimal load carrying capacity is designed.

12 Single Layer Cylinder Design

Rounded cylinder design improves stable contact with the piston to increase the product durability and to reduce the unnecessary damages such as scratches.

11 Wearing Plates

Employment of wear resistant plates between cylinder, front head and housing increases the overall product durability.

10 Single Tool Retainer Pin

Correct tool alignment and dispersion of tool wear.

9 Field Replaceable Tool Bushing

Convenient for field replacement and protect the front head.

8 Working Tool

Heat treated and optimal length for efficient breaking.

※ Note : some features may be adjusted due to the drawing updates by the manufacturer.

MS Series Section Feature (Small Size : MS 220)

1 Dual N2 Gas Charged Accumulators

Rechargeable dual N2 gas accumulators to assist power stroke and to reduce the surge pressure and the spikes from the hydraulic circuit of the excavator. Under the back pressure condition, the dual accumulator system is effectively worked well.

2 Auto Grease Refiller

Compact auto grease refiller is equipped as an optional feature. Easy daily refill is serviced and continuous greasing is available as long as the breaker is operated (Not shown on the illustration).

3 Piston

Most efficient design for maximum energy transfer and recoil reduction as well as ideal match of tool and piston diameters. It transfers highest shock wave into the breaking objects.

4 Efficient Power Transfer (Piston to tool)

Optimum transfer of blow energy into the material and the reduction of the recoil.

5 Base Buffer

Vibration absorber and suspension device to protect the powercell. (Not shown on the illustration)

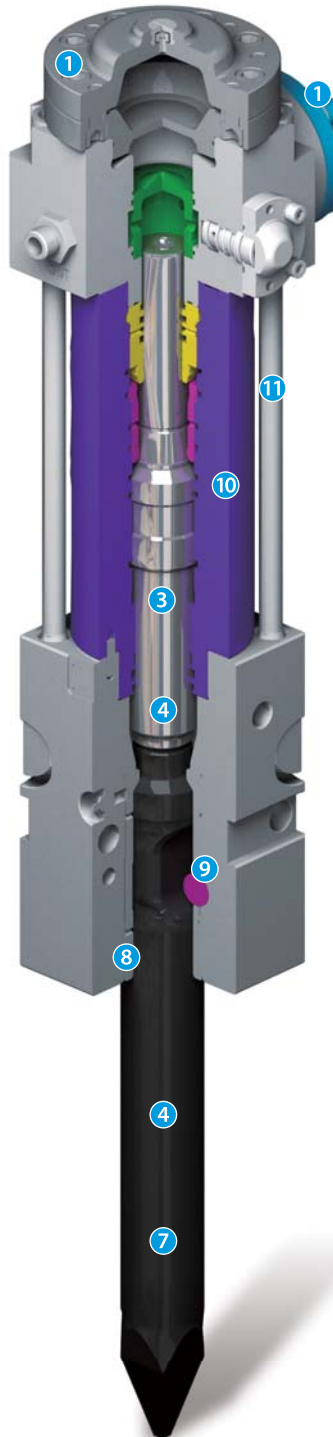

11 Side(Tie) Rods

Fully closed side (tie) rods enlarges the durability and the optimal load carrying capacity is designed.

10 Single Layer Cylinder Design

Rounded cylinder design improves stable contact with the piston to increase the product durability and to reduce the unnecessary damages such as scratches.

9 Single Tool Retainer Pin

Correct tool alignment and dispersion of tool wear.

8 Field Replaceable Tool Bushing

Convenient for field replacement and protect the front head.









7 Working Tool

Heat treated and optimal length for efficient breaking.

6 Housing Bottom Plate

Abrasion-resistant plate delivers breaker protection (Not shown on the illustration).

MSB Working Tool Selections

No	Name of Working Tool	Tool Configurations	Recommended Applications
1	Moil		Universal usage Concrete breaking Rock breaking Road construction
2	Moil(Long)		Universal usage Concrete breaking Rock breaking Road construction
3	Cone		Universal usage Soft & nonabrasive work
4	Chisel		Mining Trenching Ground work Slope breaking
5	Dust Chisel		Mining Trenching Ground work Slope breaking
6	Asphalt Cutter		Frozen ground Asphalt cutting
7	Blunt		Mining Block holing Secondary breaking Slag removal
8	Slab Buster		Slab demolishing Lower tool wear application
9	Tank Cutter		Container chopping Special application for two tips' breaking



MSB



MSB CORPORATION

MASTER OF SUPER BREAKERS

Address : 91, Namdong-Daero, Namdong-Gu, Incheon City, Korea
Tel: +82-32-821-6980 / Fax: +82-32-818-1698 / E-mail: msb@msbcom.co.kr

www.msbcom.co.kr

Literature S/N : 201602A-2

