

Dimension

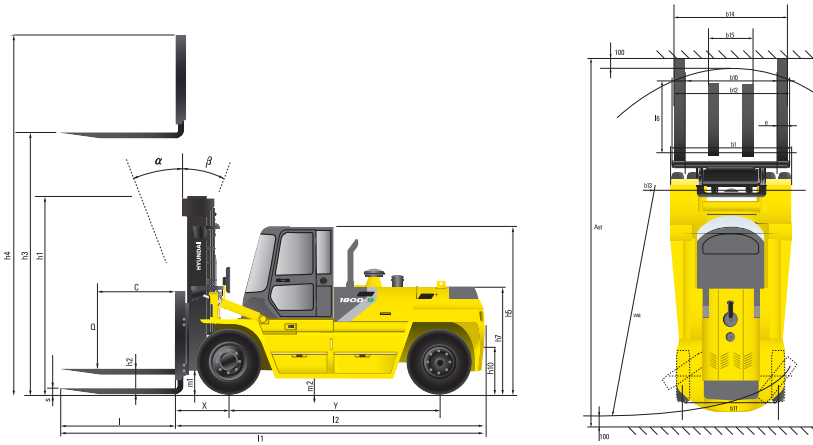

Mast Specification

Mast Type	Maximum Fork Height(in)	Overall Height Lowered(in)	Tilt Angle (deg) Fwd / Bwd	Load Capacity (36in LC)(lb)	Truck Weight Unloaded(lb)	
SIMPLEX MAST	V300	118.9	10 / 10	40,000	57,246	
	* V330	130.7	10 / 10	40,000	57,528	
	V350	138.6	135.8	10 / 10	40,000	57,694
	V400	158.3	145.7	10 / 10	40,000	58,513
	V450	178.0	155.5	10 / 10	40,000	58,834
	V500	197.6	165.4	10 / 10	40,000	59,664
	V550	217.3	175.2	10 / 10	40,000	60,138
	V600	237.0	185.0	10 / 10	40,000	60,611
	V650	256.7	194.9	10 / 10	40,000	61,045
	V700	276.4	204.7	10 / 10	40,000	61,465
TRIPLEX MAST	TS460	182.4	116.1	40,000	60,296	
	TS508	200.2	122.0	40,000	60,676	
	TS538	212.0	126.0	10 / 10	40,000	61,052
	TS568	223.8	129.9	10 / 10	40,000	61,255
	TS600	238.0	134.6	10 / 10	40,000	61,557
	TS658	259.2	141.7	10 / 10	40,000	61,986
	TS700	276.9	147.6	10 / 10	40,000	62,314

Load Capacity

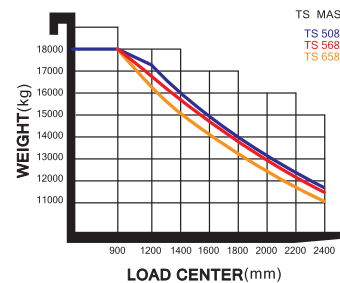
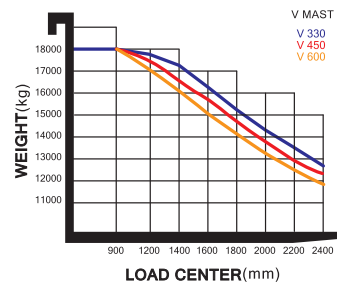

Optional Items

- Fork(L x W x T)(in)
106 x 9.8 x 4.3 / 124 x 9.8 x 14.3 / 144 x 9.8 x 4.3 / 146 x 9.8 x 4.3
- MCV : 6-SPOOL
- Air compressor
- Separator holder type fork carriage
- Beacon lamp

Specification

Identification		
1.1	Manufacturer	HYUNDAI
1.2	Manufacturer's type designation	180D-9
1.3	Drive : electric(battery or mains), diesel, petrol, fuel gas, manual	DIESEL
1.4	Type of operation : hand, pedestrian, standing, seated, order - picker	seated
1.5	Load capacity / rated load	lb 40,000
1.6	Load center distance	c in 36
1.8	Load distance, center of drive axle to fork	x in 39
1.9	Wheelbase	y in 147.6
Weights		
2.1	Service weight	lb 57,528
2.2	Axle loading, loaded front / rear	lb 88,110 / 9,447
2.3	Axle loading, unloaded front / rear	lb 28,332 / 29,542
Wheels, Chassis		
3.1	Pneumatic	Pneumatic
3.2	Tires size, front(φ x width)	12.00 - 20 - 20PR
3.3	Tires size, rear(φx width)	12.00 - 20 - 20PR
3.5	Wheels, number front rear(x = driven wheels)	4 x 2
3.6	Track width, front	in 73.2
3.7	Track width, rear	in 90.6
Basic Dimensions		
4.1	Mast / fork carriage tilt forward / backward	degrees 10 / 10
4.2	Lowered mast height	h1 in 131.9
4.3	Lift height	h3 in 130.7
4.4	Extended mast height	h4 in 195.3
4.5	Overhead guard (cab) height	h5 in 117.7
4.6	Seat height / Standing height	h7 in 84.6
4.7	Coupling height	h10 in 24.0
4.8	Overall length	l1 in 316.7
4.9	Length to face of forks	l2 in 220.3
4.10	Overall width	b1 in 100.0
4.11	Fork dimensions	s / e / l in 3.9 x 9.8 x 96.5
4.12	Fork - carriage width	b3 in 116.1
4.13	Ground clearance, loaded, under mast	m1 in 9.6
4.14	Ground clearance, centre of wheelbase	m2 in 14.6
4.15	Aisle width for pallets 1,000 x 1,200 crossways	Ast in 353.7
4.16	Aisle width for pallets 800 x 1,200 lengthways	Ast in 353.7
4.17	Turning radius	Wa in 205.5
4.18	Smallest pivot point distance	mm 80.6
Performance Data		
5.1	Travel speed, unloaded	mph 23
5.2	Lift speed, loaded/ unloaded	mm/s 72.8 / 82.7
5.3	Lowering speed, loaded/unloaded	mm/s 82.7 / 59.1
5.5	Drawbar pull, Loaded	KN 150
5.7	Gradient performance, Loaded	% 31.1
5.10	Service brake	Wet, Hydraulic
Engine		
6.1	Engine manufacturer / type	BENZ(MTU)
6.2	Engine power acc. to ISO 1585	hp 281
6.3	Rated speed	1/min 2,200
6.4	No. of cylinder / cubic capacity	/cm ³ 7,700
6.5	Fuel consumption acc. To VDI cycle	l/h 14.8
Other Details		
8.1	Type of drive control	Power Shift
8.2	Operating pressure for attachments(system/attach)	240 / 160
8.3	Oil volume for attachments	270
8.4	Sound level at driver's ear according to DIN 12 053	76.9

- Air Conditioner & Heater
- Rear view camera

180D-9

Performance Enhanced For Tier-4 Final

MOVING YOU FURTHER

HYUNDAI HEAVY INDUSTRIES



HYUNDAI
MATERIAL HANDLING

6100 Atlantic Blvd Norcross, GA 30071
TEL (678) 823 7777 FAX (678) 823 7778



PLEASE CONTACT

www.hyundaiforkliftamericas.com 2018.04 Rev.2

Some of the photos may include optional equipment.

HYUNDAI
MATERIAL HANDLING

Your satisfaction is our priority!

Hyundai introduces a new line of 9-series diesel forklift trucks. The newly designed 4 wheel counterbalance trucks provide every operator comfortable driving, increased productivity and easy maintenance.



An ideal arrangement of components ensures easy access and convenience for maintenance.

180D-9



Hi-mate (Remote Management System)

Hi-mate, Hyundai's proprietary remote management system, provides operators and dealer service personnel access to vital service and diagnostic information on the machine from any computer with internet access.



Rear View Camera (Option)

The rear view camera makes the operation even more convenient. And it supports 4 camera channels.



Some of the photos may include optional equipment.

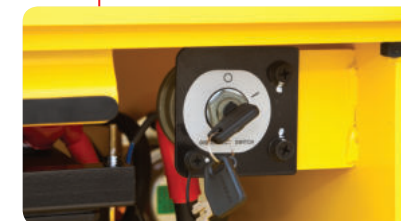

Master Switch

A master switch disconnects the battery power to protect the electrical system from excess electrical drainage.



Maintenance Management Display

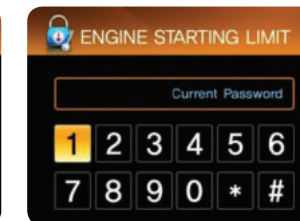

Engine Start Limit

Fast and Easy Maintenance

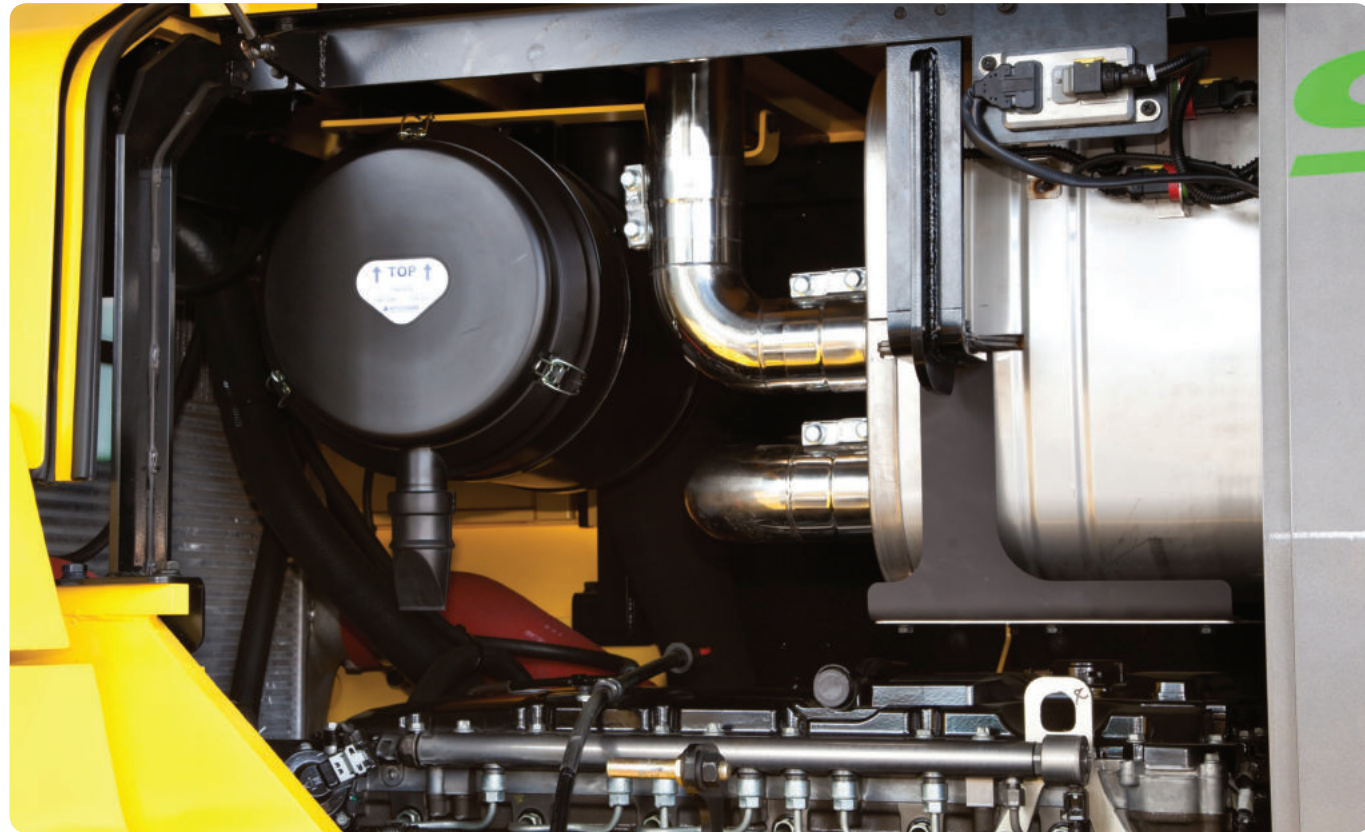

Large Engine Hood

Highly accessible engine compartment assures fast and efficient maintenance.

Some of the photos may include optional equipment.



Easy Change Air Cleaner

This air filter is readily accessible for cleaning or replacement.

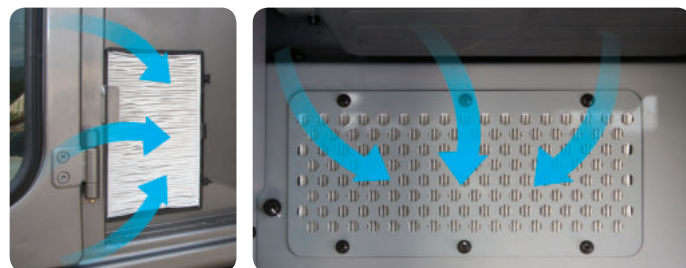

Cabin Air Fresh Filter

The internal pressure is maintained to be slightly higher than that of outside to exclude dust and to reduce noise levels.

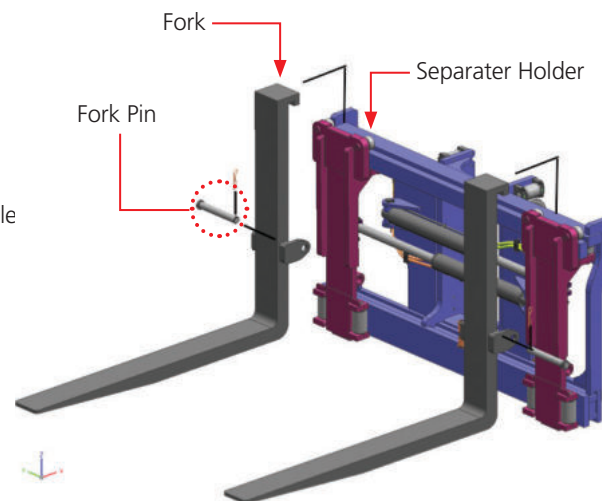

Separator holder type Fork Carriage(Optional)

Removal and replacement of various attachments and forks can be done effortlessly with the separator holder system, improving handling while reducing downtime.

New Diesel Forklift with Proven Quality and Advanced Technology

- Maximum performance
- Spacious operator's cab
- Load indicator system
- OPSS system for safe operation
- Easy serviceability
- Hi-mate (Remote Management System)



Some of the photos may include optional equipment.

High Efficiency & Optimal Performance

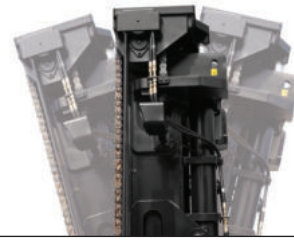

The safely designed compartment makes operations more comfortable.

180D-9



Some of the photos may include optional equipment.

OPSS (Operator Presence Sensing System)

When the operator is not in the seat all mast and drive movements are not functional.

Lift Lock Tilt Lock Drive Lock



Some of the photos may include optional equipment.



Benz(MTU) OM936(6R1000) Engine 281hp/2,200rpm

Powerful Engine

The six cylinders turbo-charged engine is built for power, reliability and economy. This engine meets EPA Tier 4 and EU stage 8 emission regulation.

Excellent fuel efficiency

Fuel consumption rate is improved than previous model.

SCR (Selective Catalytic Reduction)

No DPF and no DOC required

EGR(Exhaust Gas Recirculation)

- High torque at low speeds
- Excellent transient behavior

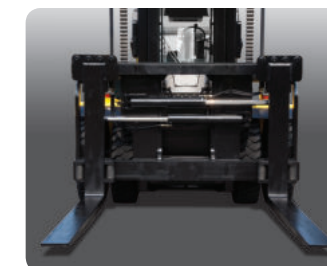

Highly durable Carriage

Applying high tensile structural steel, the carriage has excellent durability.



Large footboard & Handle

Wide "open" step offers convenience and safety when entering and exiting the truck.



Excellent Night Work

- Various position of work lamp provides the operator more comfortable and safe operating environments.
- Front : fender(2), mast(4) - Rear : cab(2)
- LED Rear Combination Lamp



Advanced Safety

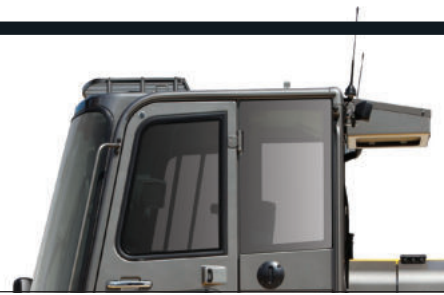

Powerful Tier IV Final Diesel engine and high technology systems provide you with enhanced performance and highest productivity.

180D-9

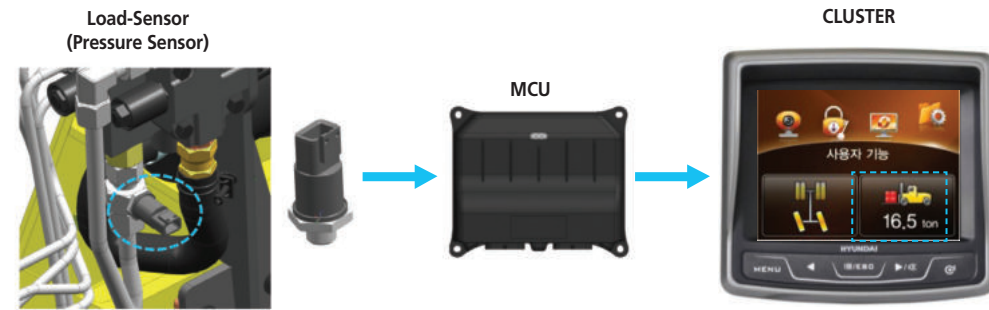

Load indicator

The optional load indicator displays the load weight within the monitor. The load sensor reduces the time to check loaded weight and the alarm alerts the driver when overloaded.

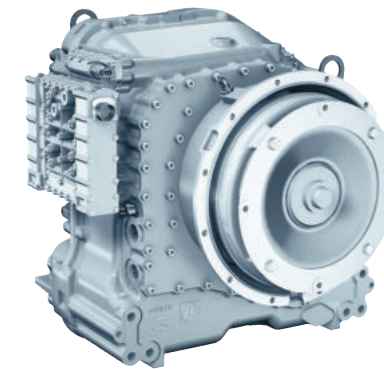

ZF Full-automatic Transmission

Full-automatic transmission offers convenient handling and soft, smooth shifting. The operator can select two kinds of automatic modes. (1st 3rd, 2nd 3rd)
Improved Torque converter with stator free wheel provides enhanced fuel efficiency.

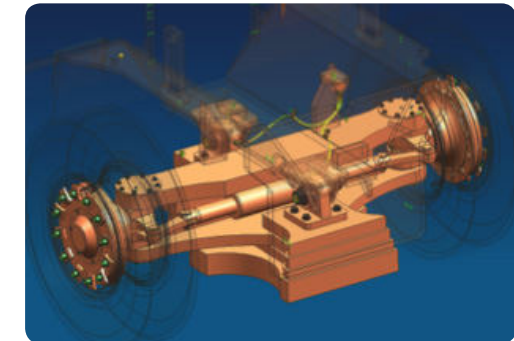

Fully Hydrostatic Power Steering

The hydraulic steering system always guarantees smooth and flexible steering, preventing over-run and kick-back.

Load Sensing System

Hydraulic fluid is only applied based on sensing pressure and load weight.



Adjustable Engine Low Idle RPM

While engine is running, low idle rpm can be increased in increments of 25rpms, and it keeps previously set rpm when engine restarts. When starting, engine rpms return to original.

Kessler Durable drive axle

The planetary reduction drive axle smoothly delivers desired torque to the drive wheels.

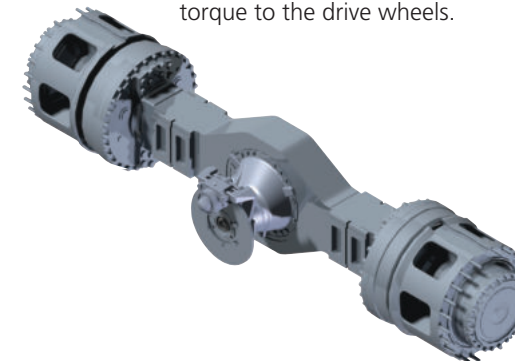

Wet Disc Brake System

The wet disc brake system is virtually maintenance free and is enclosed to protect from dust and water.

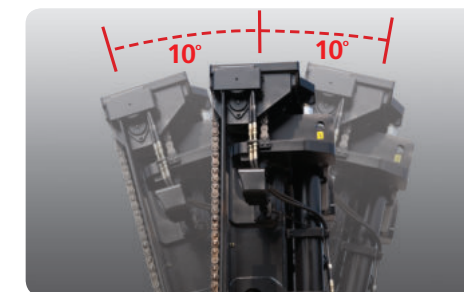

Increased mast tilting angle

Utilizing the mast tilting angle of 10 degrees forward and 10 degrees backward, the operator can perform loading and unloading jobs safely and rapidly.



State-of-the-Art Cooling System

The minimum fuel consumption and low noise are available by applying hydraulic cooling fan sensing intake air temperature, transmission oil temperature, coolant temperature and hydraulic temperature.

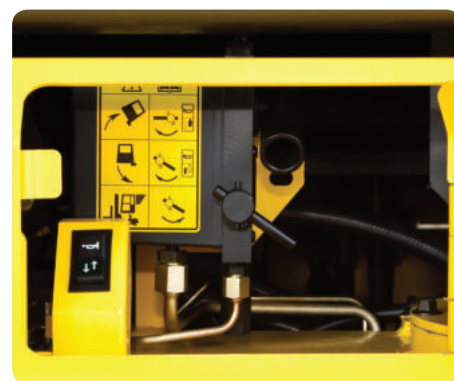

Electronic Cab Tilting System

Electronic Cab Tilting System makes servicing of all power train components quick and easy. An electrically assisted hydraulic actuated cylinder tilts enclosed cab to left side about 65 degrees for easy access to truck components.

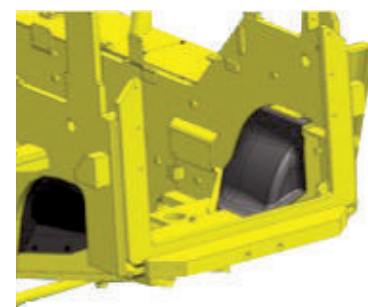

Rear Tire cover

The Rear tire cover is included to prevent clogging of the radiator from foreign substances.



Max.Gradeability (loaded/Unloaded)		Max.Travel Speed (Unloaded)	
Model	%	Model	mph
180D-9	31.1 / 30.4	180D-9	23

Faster Travel Speed & Better Gradability

The powerful engine provides greater acceleration, better gradability and faster travel speed on any tough terrains or slopes.

Optimized Ergonomics



The ergonomically designed cabin provides full support and comfort to the operator.

180D-9



Spacious operator cabin

The newly designed cabin was conceived for more space, a wider field of view and operator comfort.

Some of the photos may include optional equipment.



Quick Response of Operating Control Levers

Only minimal operator's effort is required for precise, safe and productive control.



Ergonomically positioned pedals

Based on human engineering, the accelerator, brake and inching pedals are optimally positioned for the operator's convenience.

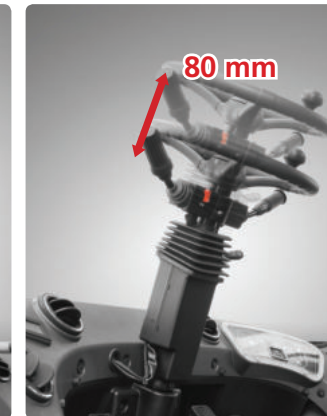
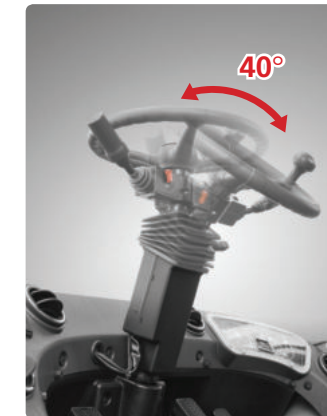

Top-Wiper (STD)

Offers clear visibility on the roof

Adjustable steering column

The steering wheel assembly is easily adjustable, allowing all size of operators excellent comfort.



MP3 CD Player & Remote Control



Bluetooth Hands Free Socket (Option)



Centralized Instrument switch Panel



Luxury(Air-suspension+Heat+HeadRest) seat(Option)

An attractive and adjustable seat, based on a human engineering design, provides great comfort, safety and durability.

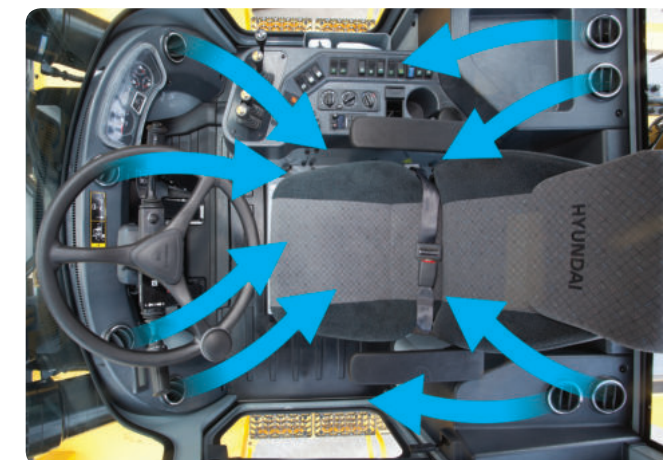

High-output Air Conditioner & Heater

An air conditioner with high-output and heater always provides you with comfortable environment when you work.