



COMPACT EXCAVATOR SALES LLC

400 Production Court
Elizabethtown, KY 42701
Phone: 800.538.1447 Fax
270.737.0419
www.ihices.com



17VXE Electric Excavator 3 Phase/480 Volt

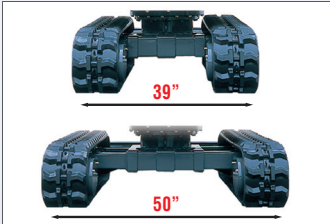

- ⚡ Hydraulic Controlled
- ⚡ Retracted is 39" total unit width
- ⚡ Expanded is 50" total unit width



- ⚡ 15 h.p./3phase/48 volt/ 50 amp Reuland Motor

- ⚡ Key start
- ⚡ E-Stop
- ⚡ Soft start protected
- ⚡ Reverse rotation protected
- ⚡ Low voltage protected
- ⚡ Low amperes protected
- ⚡ Over current protected
- ⚡ Ground fault protected



Standard Items:

- 18" Bucket
- Auxillary Piping ¹
- Additional Counter Weight ²
- Control Pattern Change Valve

Options:

- Buckets Sizes
8" 12" 24"
- 39" Ditch Clean Bucket
- 39" Swivel
- Blade Extensions ³
- Hydraulic Thumb
- Quick Coupler



17VXE

ELECTRIC EXCAVATOR



Dimensions

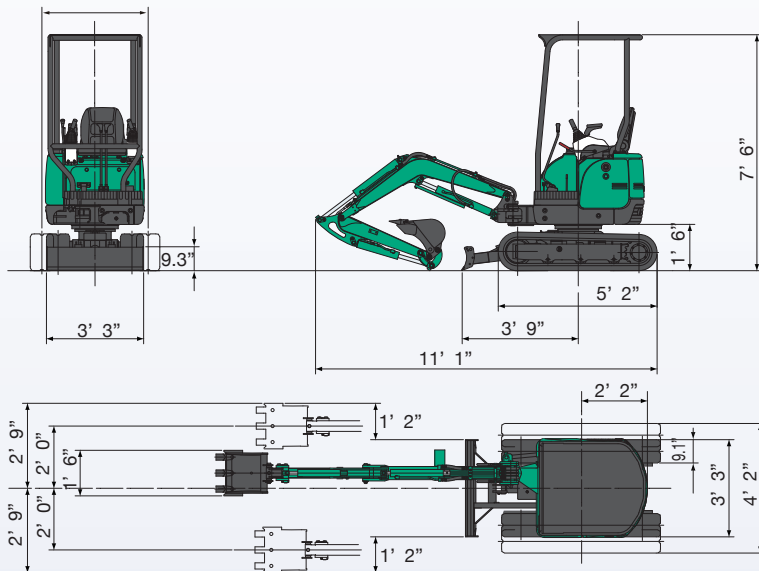

Working Range

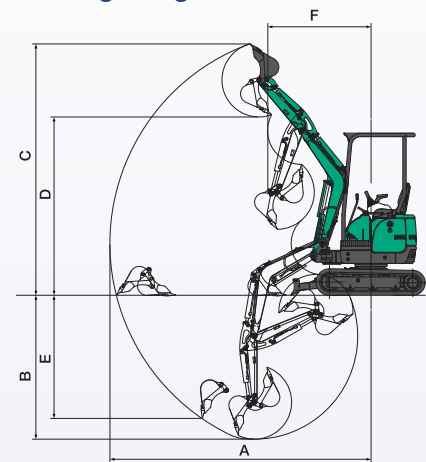

	4-Post Canopy
A Max. digging radius	12' 4"
B Max. digging depth	7' 0"
C Max. digging height	11' 10"
D Max. dumping height	8' 5"
E Max. vertical digging depth	5' 10"
F Min. front turning radius	4' 11"
At right boom swing	4' 2"

17VXE Specifications

Performance		Boom swing system	
Bucket capacity	1.6 cu. ft.	Type	Boom offset with hydraulic cylinder
Bucket width	18"	Swing angle (L/R)	55°/80°
Operating weight: 4-Post	3,583 lbs.	Hydraulic system	
Transportation weight: 4-Post	3,417 lbs.	Pressure	3000 psi
Swing speed	9.5 min ⁻¹	Pump • type/hydraulic flow	2 Piston/2 Gear • 4.5 gal/min x 2 + 3.2 gal/min
Travel speed (low/high)	1.3/2.5 mph	Dozer blade	
Gradeability	30°	Size	37.8" x 9.3"
Ground pressure	3.8 psi	Lift above ground / Drop below ground	10.8"/12"
Max bucket digging force	5,447 lbs.	Max auxiliary flow	
		Auxiliary line	7.7 gal/min
Motor			
	Rueland 15 H.P. 3PH. 480V		

Distributed by **Compact Excavator Sales LLC**

400 Production Court, P.O. Box 667 • Elizabethtown, KY 42702-0667 • Phone: 1-800-538-1447 • Fax: 270-737-0419

www.ihices.com