



1600-69 OC Portable Impactor Plant

The Eagle Crusher 1600-69 OC is the largest UltraMax® impactor plant—a mammoth in the industry—for your largest-sized jobs.

Features

- 1 Available with a separate side-discharge conveyor (OC model) or with a built-in front-discharge conveyor (CV model). You decide, depending on your set-up requirements.
- 2 Available in-line electro-magnet.
- 3 Hydraulic lift and leveling system for set up and tear down.
- 4 Designed for all-electric power.
- 5 Side-discharge conveyor includes a pan feeder, receiving hopper, replaceable liners, and optional full-length skirtboards.
- 6 The electrical control panel for the crusher and the auxiliary plant equipment are designed to be free standing for ease of placement on the job.
- 7 Features the industry's only LIFETIME ROTOR WARRANTY on its solid-steel, three-bar, sculptured rotor—the industry's heaviest—to keep you up and crushing.*



* North America only.

Additional Features

- Replaces dual crusher systems for a much lower initial investment and for greatly reduced maintenance, power and transportation costs.
- Features standard grizzly bypass chute and available cross-belt conveyor with flop gate to allow for either removal of the material that passes through the grizzly deck for stockpiling or blending back with the crushed material.
- Features unique two-step, 5' grizzly deck to remove fines before crushing.
- Available grizzly cross conveyor for both OC (side-discharge unit) and CV model (front-discharge unit).
- Side-discharge conveyor is available in road-portable version.
- Manage the feeder speed for complete control of the flow of material into the impactor with Variable Frequency Drive (VFD).
- Includes wireless remote control for the feeder shutdown and all motor stop.

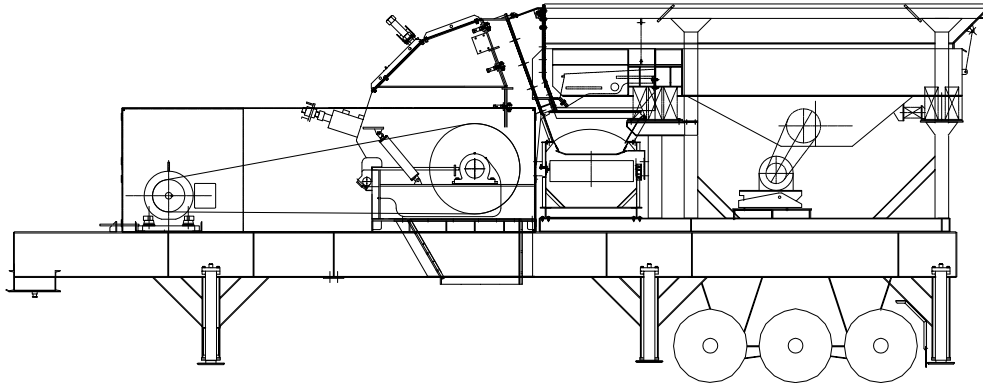

1600-69 OC Specifications*

| | |
|--------------------------------|---|
| Impactor | UM-69 |
| Overall Length | 48' 3.5" / 14.7M |
| Gross Weight | 170000lbs / 77100kgs |
| Travel Length | 44' 0" / 13.4M |
| Travel Width | 11' 11" / 3.6M |
| Travel Height | 13' 5" / 4.1M |
| Feed Hopper Capacity | 27yd ³ / 20.6M ³ |
| Feed Hopper Capacity (Tons) | 36.5T / 33.2MT |
| Vibrating Feeder | 20' x 68" / 6.1M x 1.7M |
| Feeder Grizzly Deck | 60" long 1 step / 1524mm 1 step |
| On-Plant Power Supply Electric | 500HP or 800HP option / 373kW or 800kW option all-electric power |
| Side-discharge conveyor Width | 54" / 1372mm |
| Discharge Conveyor Height | 8' 11.5" / 2730mm |

UltraMax® Impactor Model and Specifications*

| Model | Diameter x Width | Width x Height | Power Required (HP / kW) | Approx. Weight (lbs / kg) | Rotor Weight (lbs / kg) | Production Capacity** |
|-------|---------------------------------|--|-----------------------------|------------------------------|----------------------------|--------------------------|
| | Rotor (Inches / Millimeters) | Feed Opening (Inches / Millimeters) | | | | |
| UM-69 | 56 x 68 / 1422 x 1727 | 69 X 36 / 1753 x 914 | 400 - 600 / 298 - 447 | 61000 / 27700 | 26100 / 11800 | Varies by application |

*Design specifications subject to change without notice.

**Contact your Eagle Sales Representative with your specific application for anticipated production capacity.