

# ATLAS

Krane / Cranes / Grues / Grúas



# 105.2

## 105.2

Faltkran · Foldable crane · Grue repliable · Grúa articulada

### 105.2 - 5,4/1 (A1)

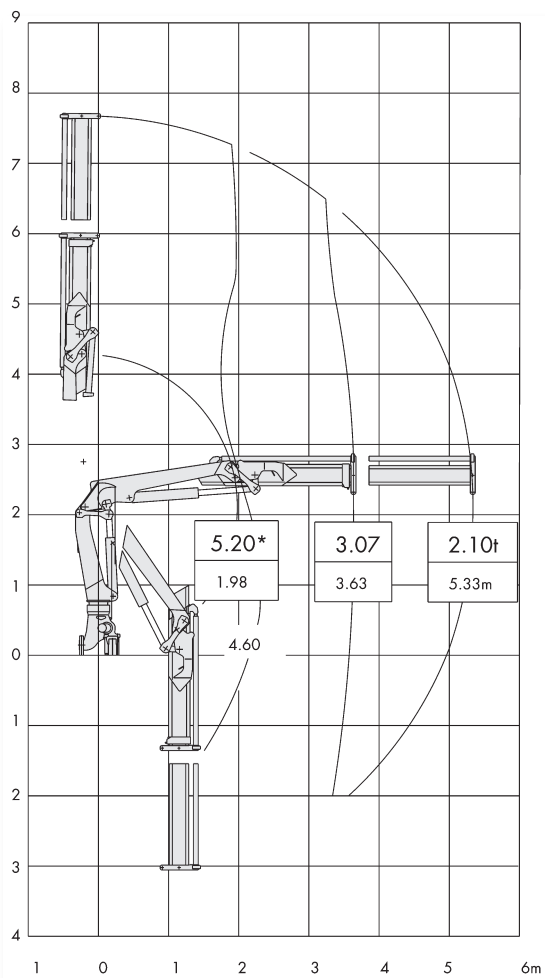

### 105.2 - 7,2/2 (A2)

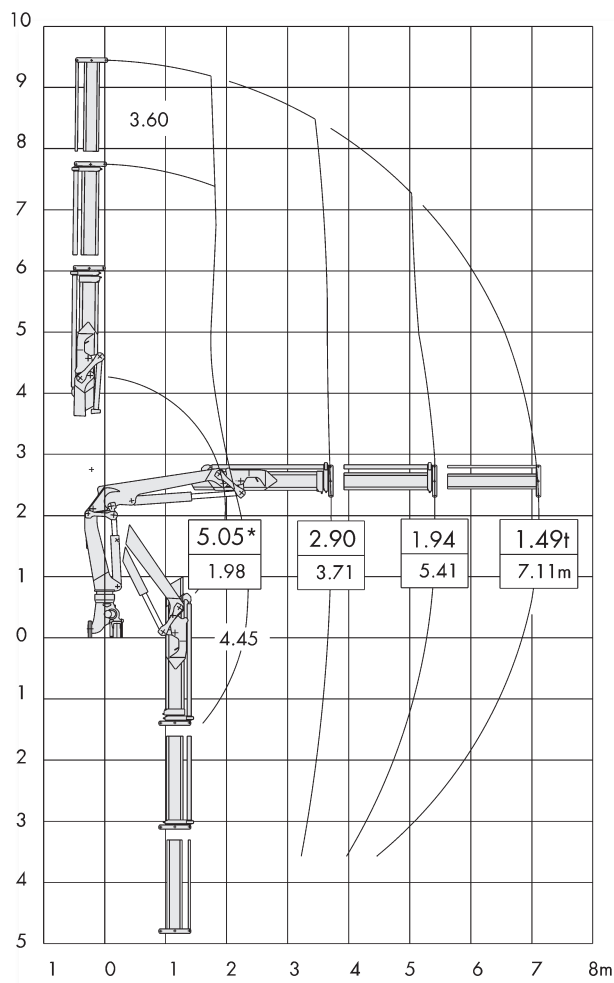

#### Allgemeine Hinweise:

- Angaben der Faltkrane bei 10° Hubarmstellung
- Für die stationäre Montage ist der Betriebsdruck zu reduzieren
- Maße in m, Traglasten in t

#### General notes:

- Lifting data based on a boom position of 10°
- For stationary installation, the operating pressure must be reduced
- Dimensions in "m", load capacities in metric "t"

#### Indications universelles:

- Flèche en position de 10°
- Il faudra réduire la pression de service pour des montage à poste fixe
- Dimensions en "m", charges en "t"

#### Indicaciones generales:

- Datos sobre las grúas articuladas cuando la posición del brazo de elevación es de 10°
- Para el montaje estacionario, es necesario reducir la presión de servicio
- Dimensión en 'm' y carga en 't'

## 105.2 - 9,0/3 (A3)

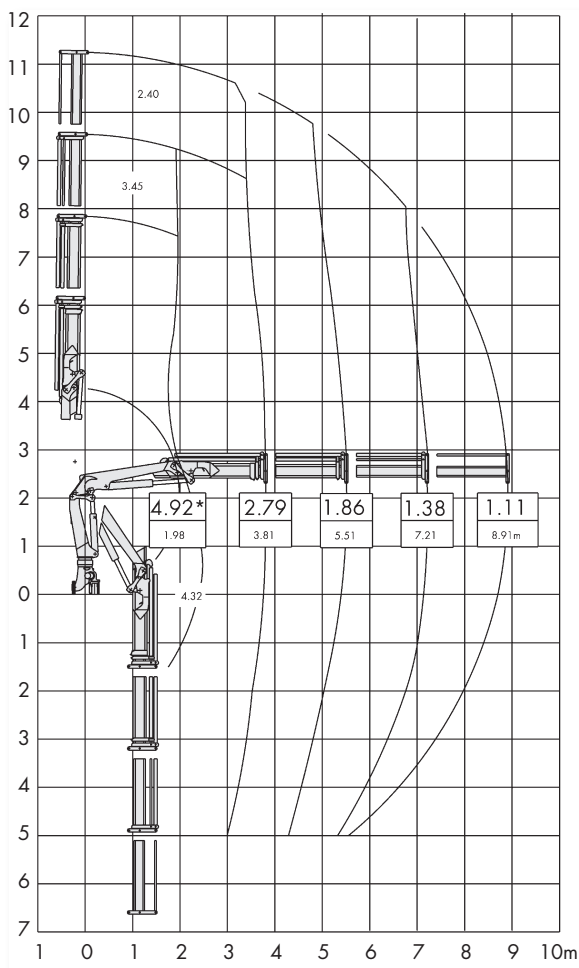

## 105.2 - 6,1/1 (A1L)

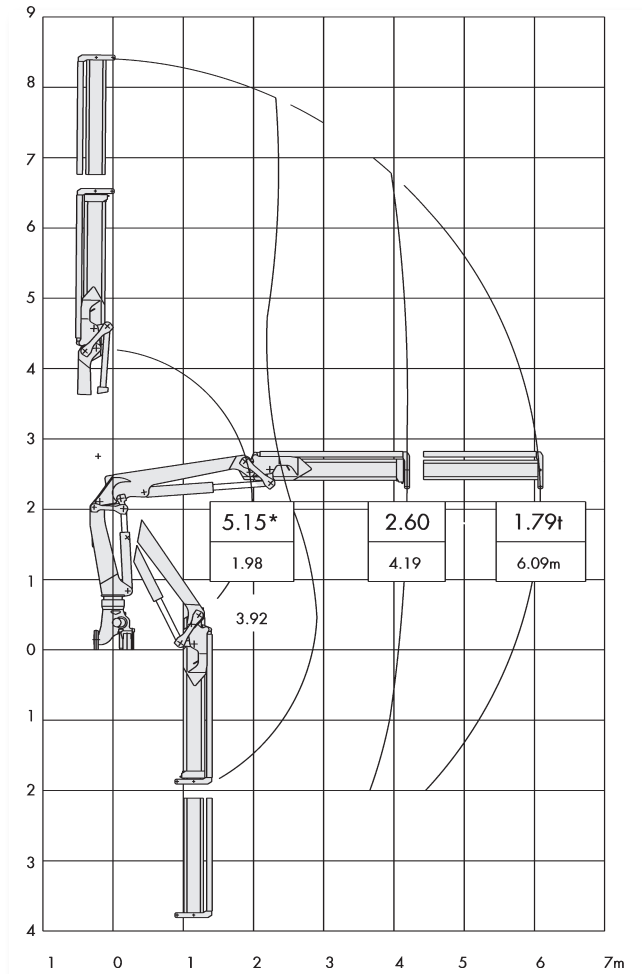

## 105.2 - 8,1/2 (A2L)

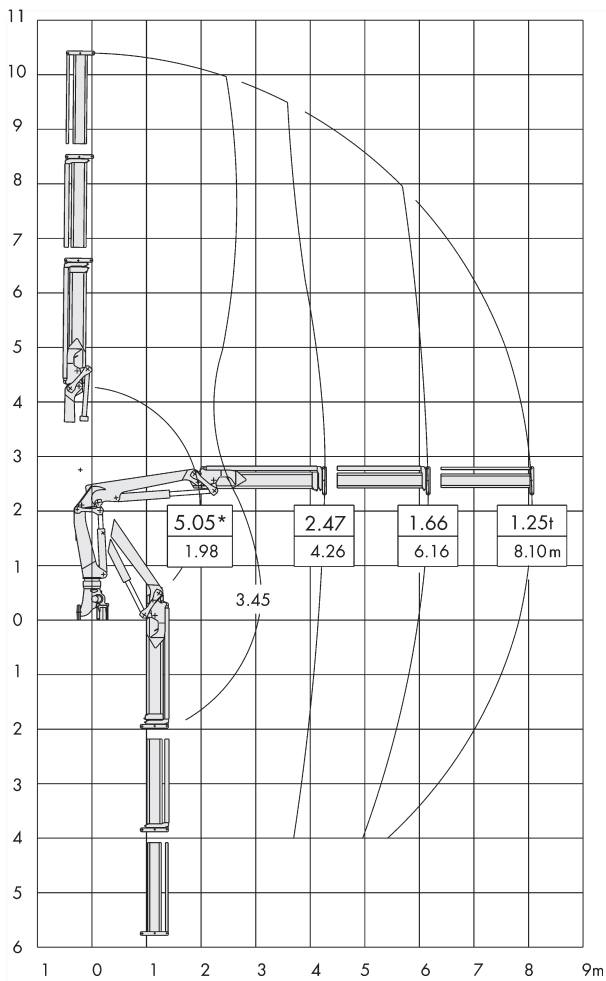

## 105.2 - 10,2/3 (A3L)

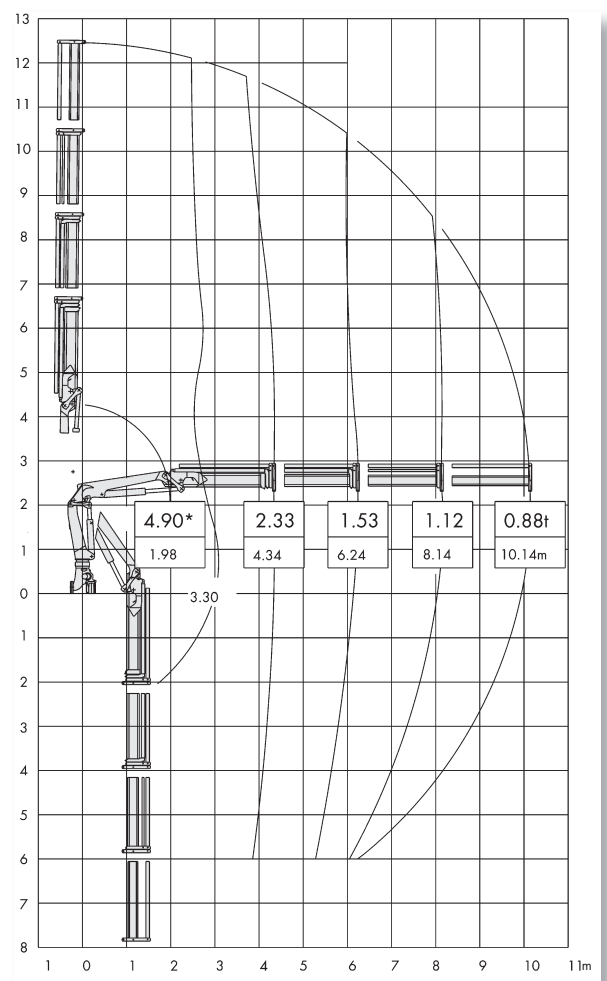

## 105.2 - 12,3/4 (A4L)

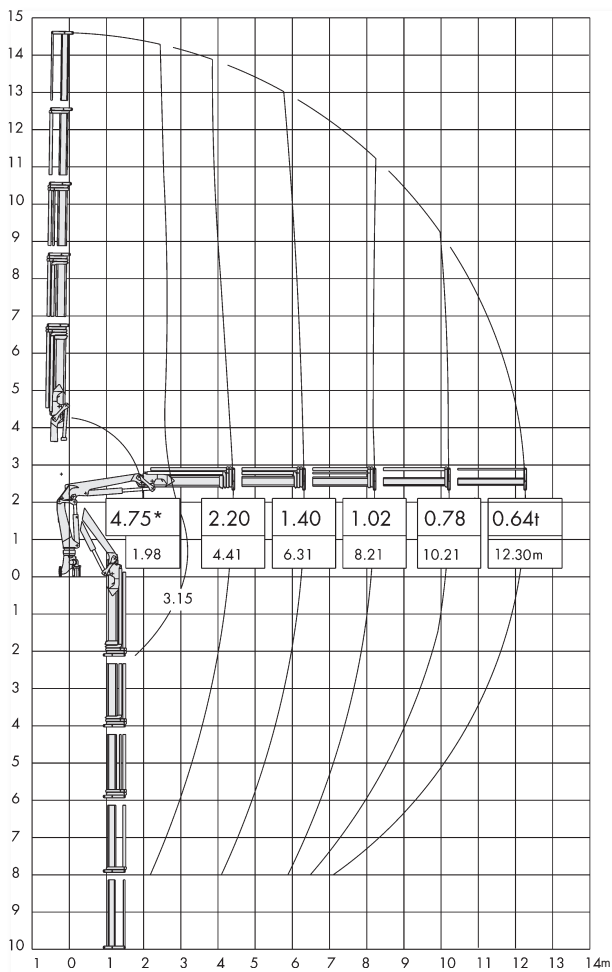

## 105.2 - 14,4/5 (A5L)

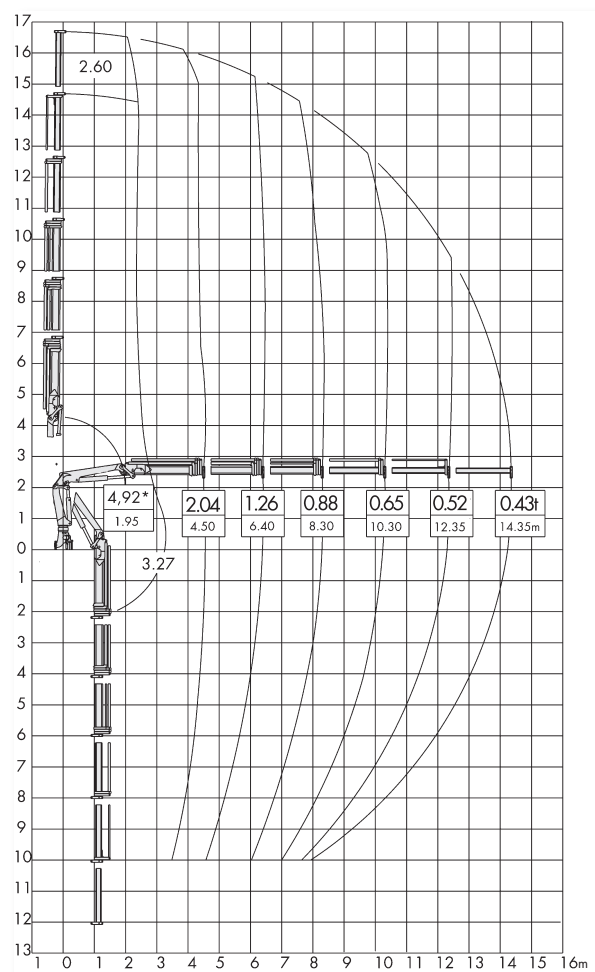

Konstruktionsänderungen vorbehalten, Angaben unverbindlich, Geräte sind konform mit neuen europäischen Sicherheitsrichtlinien.

Design modifications reserved, specifications non-binding, units are in conformance with new European safety guidelines.

Sous réserve de modifications de la construction, indications sans engagement, les engins sont conformes aux nouvelles directives européennes en matière de sécurité.

Reservados los derechos de modificación de componentes.  
No nos responsabilizamos de la información aquí descrita. La maquinaria cumple las directivas europeas de seguridad.

# 105.2

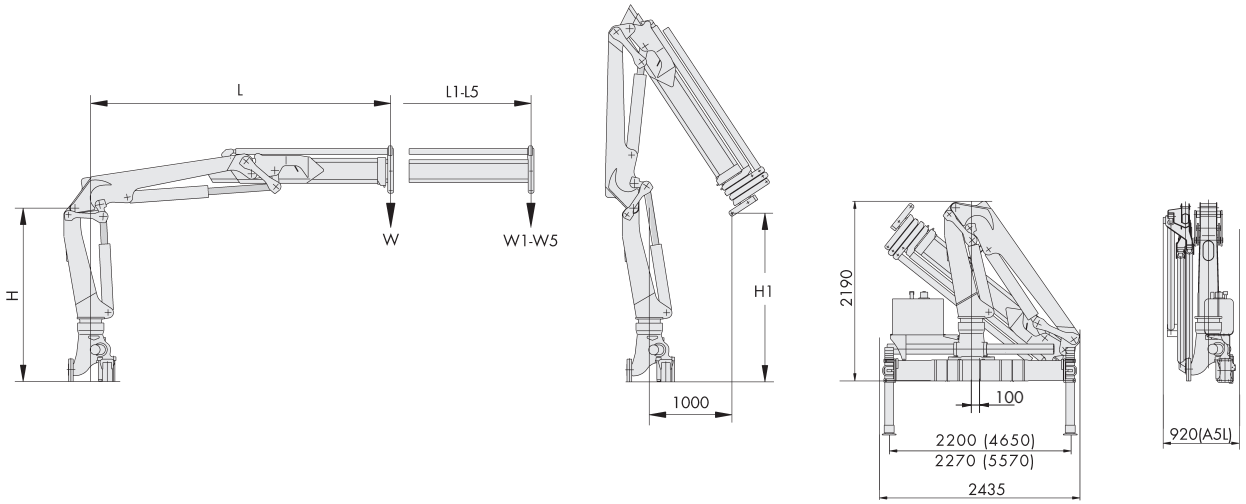

Typ type tipo	Höhe height hauteur altura	Höhe height hauteur altura	Traglast bei der jeweiligen Ausladung load at the respective reach charge de levage à la portée respective capacidad al alcance respectivo											
	H m	H1 m	L m	W t	L1 m	W1 t	L2 m	W2 t	L3 m	W3 t	L4 m	W4 t	L5 m	W5 t
A1	2,11	3,13	3,63	3,07	5,33	2,10	7,02*	1,55*						
A2	2,11	3,03	3,71	2,90	5,41	1,94	7,11	1,49						
A3	2,11	2,89	3,81	2,79	5,51	1,86	7,21	1,38	8,91	1,11				
A1L	2,11	2,42	4,19	2,60	6,09	1,79	8,07*	1,30*						
A2L	2,11	2,33	4,26	2,47	6,16	1,66	8,06	1,25						
A3L	2,11	2,24	4,34	2,33	6,24	1,53	8,14	1,12	10,14	0,88				
A4L	2,11	2,16	4,41	2,20	6,31	1,40	8,21	1,02	10,21	0,78	12,26	0,64		
A5L	2,11	2,05	4,50	2,04	6,40	1,26	8,30	0,88	10,30	0,65	12,35	0,52	14,35	0,43

Typ type tipo	Hubmoment loadmoment moment de course capacidad		Ausladung reach portée alcance		Betriebsdruck working pressure pression de marche presion de trabajo	Ölfördermenge oilflow débit d'huile caudal de aceite	Schwenkbereich slewing angle g. de basculement giro	Schwenkmoment slewing moment mo. de basculement momento del giro	Gewicht weight poids peso		
	kNm	mt	hydr.	mech.	bar	l/min	°	kNm	kg**	kg***	kg****
A1	109,2	11,2	5,40	7,00	270 (190)	45	410°	16,9	1310	210 - 320	90
A2	106,0	10,8	7,20	1420							
A3	104,0	10,6	9,00	1530							
A1L	106,9	10,9	6,10	8,10					1350		
A2L	103,0	10,5	8,10	1490							
A3L	99,1	10,1	10,20	1620							
A4L	95,2	9,7	12,30	1710							
A5L	90,3	9,2	14,40	1870							

Einstufung - classification - classification - clasificación = H1 - B3

Händler:



Atlas Maschinen GmbH  
 Stedinger Straße 324 · D-27751 Delmenhorst  
 Tel. +49 (0) 4221-491-0 · Fax +49 (0) 4221-491-443  
 info@atlasgmbh.com · www.atlasgmbh.com

\* Daten für die mechanische Verlängerung / data for the manual extension / données techn. / détails pour extensions manuelles  
 \*\* einfaches Grundgerät im Lasthubbetrieb / simple basic unit for loadhook work / type de base simple avec crochet / maquina base para trabajo con gancho  
 \*\*\* je nach Ausführung der Abstützungen / depending on stabilizer / dépendant de modèle du stabilisateur / segun la version de los estabilizadores  
 \*\*\*\* Ölbehälter mit Füllung / oil tank with oil / réservoir avec contenu / depósito con aceite