



1000-15 CC Closed Circuit Plant

This plant is designed for medium-sized jobs that require cubicle spec products from a highly portable crushing and screening plant on one chassis.

Features

- ❶ One-pull transport with optional rear tag axle. Check with your DOT.
- ❷ Two-deck inclined screen produces two cubical spec products.
- ❸ Top-deck retained material is returned to the crusher for further processing.
- ❹ Hydraulic lift and leveling system enables quick set up and tear down by using the hydraulic run-on legs.
- ❺ Totally self-contained, reliable diesel/ electric or all-electric power. You won't have to worry about hydraulic leaks and failures shutting you down.
- ❻ Available in-line electro-magnet removes for transport.
- ❼ Features the industry's only LIFETIME ROTOR WARRANTY on its solid-steel, three-bar, sculptured rotor—the industry's heaviest—to keep you up and crushing.*



* North America only.

Additional Features

- Features closed-circuit crushing and screening on one chassis.
- Replaces Jaw/Cone/Screen multi-unit systems for a much lower initial investment while maintaining a high production of cubical spec product. Greatly reduces maintenance and fuel costs and is easily transported.
- Features unique two-step, 5' grizzly deck to remove fines before crushing.
- Features standard grizzly bypass chute and available cross-belt conveyor with flop gate to allow for either removal of the material that passes through the grizzly deck for stockpiling or blending back with the crushed material.
- Includes plant-mounted electrical control panel featuring pre-wired receptacles for radial stackers.
- Transports easily with the hydraulic retractable return conveyor and folding side conveyor.
- Manage the feeder speed for complete control of the flow of material into the impactor with Variable Frequency Drive (VFD).
- Includes wireless remote control for the feeder shutdown and all motor stop.

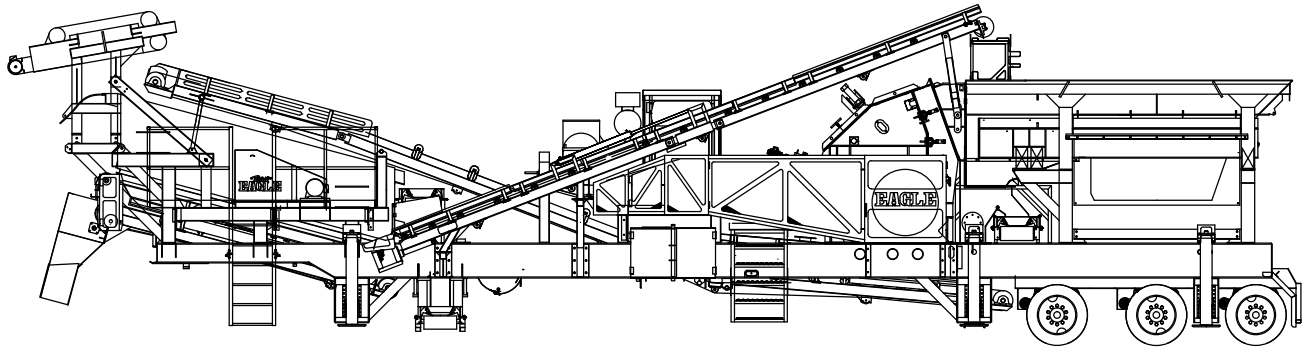

1000-15 CC Specifications*

Impactor	UM-15
Overall Length	63' 5" / 19.3M
Gross Weight	125000lbs / 56700kgs
Travel Length	57' 0" / 17.4M
Travel Width	11' 11" / 3.6M
Travel Height	13' 5" / 4.1M
Feed Hopper Capacity	11yd ³ / 8.4M ³
Feed Hopper Capacity (Tons)	14.9T / 13.5MT
Vibrating Feeder	16' x 39" / 4.9M x 1.0M
Feeder Grizzly Deck	60" long 2 step / 1524mm 2 step
On-Plant Power Supply Diesel	325HP / 242kW diesel engine and 140kW generator
On-Plant Power Supply Electric	200HP / 149kW all-electric power
Discharge Conveyor Width	42" / 1067mm
Two Deck Inclined Screen	5' x 14' / 1.5M x 4.3M
Top Screen Deck Cross Conveyor Width	18" / 457mm
Bottom Screen Deck Cross Conveyor Width	18" / 457mm
Fines Screen Conveyor Width	48" / 1219mm
Return Conveyor (Hydraulic Fold) Width	24" / 610mm

UltraMax® Impactor Model and Specifications*

Model	Diameter x Width		Width x Height		Power Required (HP / kW)	Approx. Weight (lbs / kg)	Rotor Weight (lbs / kg)	Production Capacity**
	Rotor (Inches / Millimeters)	Feed Opening (Inches / Millimeters)	Power Required (HP / kW)	Approx. Weight (lbs / kg)				
UM-15	44 x 41 / 1118 x 1041	42 x 32 / 1067 x 813	150 - 200 / 112 - 149	28000 / 12700	9750 / 4400	Varies by application.		

*Design specifications subject to change without notice.

**Contact your Eagle Sales Representative with your specific application for anticipated production capacity.